

SKF bearing maintenance handbook



© SKF, @PTITUDE, CARB, DURATEMP, HYDROCAM, INSOCOAT, KMT, KMTA, LUBRILEAN, RELIABILITY MAINTENANCE INSTITUTE, SENSORMOUNT, SPEEDI-SLEEVE, SYSTEM 24, WAVE and VIBRACON are registered trademarks of the SKF Group.

™ SKF EXPLORER is a trademark of the SKF Group.

Epocast 36 is a registered trademark of H. A. Springer marine + industrie service GmbH, an Illinois Tool Works company

© SKF Group 2011

The contents of this publication are the copyright of the publisher and may not be reproduced (even extracts) unless prior written permission is granted. Every care has been taken to ensure the accuracy of the information contained in this publication but no liability can be accepted for any loss or damage whether direct, indirect or consequential arising out of the use of the information contained herein.

PUB SR/P7 10001/1 EN · September 2011

ISBN 978-91-978966-4-1

Certain image(s) used under license from Shutterstock.com.

Certain images updated due to GDPR.

1	Basics	8	1
2	Mounting rolling bearings	44	2
3	Mounting bearing units	92	3
4	Mounting bearing housings	122	4
5	Installing seals	140	5
6	Alignment.	158	6
7	Lubrication	178	7
8	Inspection.	216	8
9	Troubleshooting	228	9
10	Dismounting.	252	10
11	Bearing damage and their causes	288	11
12	Maintenance support.	324	12
13	Appendices	332	13
14	Index.	438	14

SKF bearing maintenance handbook

Foreword

The SKF bearing maintenance handbook is a comprehensive working guide for the maintenance professional. With the recommendations in this handbook, SKF aims to encourage safe and skilful maintenance practices that can help extend bearing service life, reduce machine downtime and minimize unplanned maintenance activities.

This handbook is not intended as an application design catalogue. For detailed information about designing bearing arrangements, visit www.skf.com/bearings.

Structure of the handbook

The handbook is divided into fourteen chapters, marked with numbered blue tabs in the right margin:

- Chapter 1 covers the basics of bearings, related products, and bearing arrangements.
- Chapters 2 to 5 contain instructions for mounting rolling bearings, bearing housings, bearing units, and seals.
- Chapter 6 describes the maintenance activities associated with machine alignment.
- Chapter 7 provides information and recommendations for important maintenance activities in the bearing-related field of lubrication.
- Chapter 8 covers the maintenance activities of inspection and condition monitoring.
- Chapter 9 is about troubleshooting, presenting common trouble conditions and suggested solutions.

- Chapter 10 contains instructions for dismounting rolling bearings, bearing units, bearing housings and seals.
- Chapter 11 is dedicated to bearing damage, including the ISO classification.
- Chapter 12 provides an overview of SKF's additional resources for maintenance support.
- Chapter 13 contains Appendices, with important reference information needed for maintenance work as well as an overview of SKF maintenance products.
- Chapter 14 is the Index.

Every care has been taken to ensure the accuracy of the information and that the instructions contained in this handbook are clear and reflect sound practice, but no liability can be accepted for any errors or omissions as well as from any misuse of tools and other equipment supplied by SKF.

A note about sustainability

Sustainability is about conducting activities in a resource-efficient manner so that future generations will not be compromised. There are many areas within bearing maintenance where energy can be saved, from waste management to reduction in lubricant usage to the proper use of equipment and tools. SKF is committed to a sustainable environment and encourages others to contribute to energy and materials savings.

This is SKF

From one simple but inspired solution to a misalignment problem in a textile mill in Sweden, and fifteen employees in 1907, SKF has grown to become a global industrial knowledge leader. Over the years, we have built on our expertise in bearings, extending it to seals, mechatronics, services and lubrication systems. Our knowledge network includes 46 000 employees, 15 000 distributor partners, offices in more than 130 countries, and a growing number of SKF Solution Factory sites around the world.



Research and development

We have hands-on experience in over forty industries based on our employees' knowledge of real life conditions. In addition, our world-leading experts and university partners pioneer advanced theoretical research and development in areas including tribology, condition monitoring, asset management and bearing life theory. Our ongoing commitment to research and development helps us keep our customers at the forefront of their industries.



SKF Solution Factory makes SKF knowledge and manufacturing expertise available locally to provide unique solutions and services to our customers.

Meeting the toughest challenges

Our network of knowledge and experience, along with our understanding of how our core technologies can be combined, helps us create innovative solutions that meet the toughest of challenges. We work closely with our customers throughout the asset life cycle, helping them to profitably and responsibly grow their businesses.

Working for a sustainable future

Since 2005, SKF has worked to reduce the negative environmental impact from our operations and those of our suppliers. Our continuing technology development resulted in the introduction of the SKF BeyondZero portfolio of products and services which improve efficiency and reduce energy losses, as well as enable new technologies harnessing wind, solar and ocean power. This combined approach helps reduce the environmental impact both in our operations and our customers' operations.



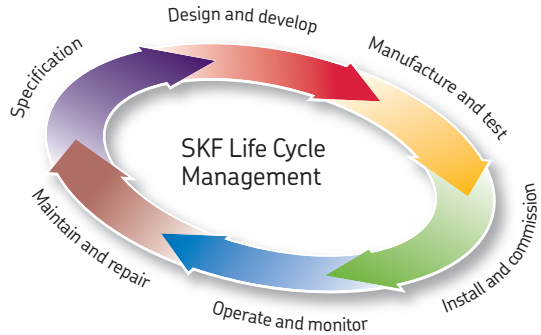
Working with SKF IT and logistics systems and application experts, SKF Authorized Distributors deliver a valuable mix of product and application knowledge to customers worldwide.



SKF – the knowledge engineering company

Our knowledge – your success

SKF Life Cycle Management is how we combine our technology platforms and advanced services, and apply them at each stage of the asset life cycle, to help our customers to be more successful, sustainable and profitable.



Working closely with you

Our objective is to help our customers improve productivity, minimize maintenance, achieve higher energy and resource efficiency, and optimize designs for long service life and reliability.

Innovative solutions

Whether the application is linear or rotary or a combination, SKF engineers can work with you at each stage of the asset life cycle to improve machine performance by looking at the entire

application. This approach doesn't just focus on individual components like bearings or seals. It looks at the whole application to see how each component interacts with each other.

Design optimization and verification

SKF can work with you to optimize current or new designs with proprietary 3-D modelling software that can also be used as a virtual test rig to confirm the integrity of the design.



Bearings

SKF is the world leader in the design, development and manufacture of high performance rolling bearings, plain bearings, bearing units and housings.



Machinery maintenance

Condition monitoring technologies and maintenance services from SKF can help minimize unplanned downtime, improve operational efficiency and reduce maintenance costs.



Sealing solutions

SKF offers standard seals and custom engineered sealing solutions to increase uptime, improve machine reliability, reduce friction and power losses, and extend lubricant life.



Mechatronics

SKF fly-by-wire systems for aircraft and drive-by-wire systems for off-road, agricultural and forklift applications replace heavy, grease or oil consuming mechanical and hydraulic systems.



Lubrication solutions

From specialized lubricants to state-of-the-art lubrication systems and lubrication management services, lubrication solutions from SKF can help to reduce lubrication related downtime and lubricant consumption.



Actuation and motion control

With a wide assortment of products – from actuators and ball screws to profile rail guides – SKF can work with you to solve your most pressing linear system challenges.



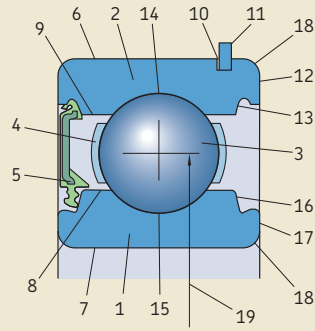
Terminology	10	Methods of bearing location	31
Rolling bearing types and designs	12	Radial location of bearings.	31
Radial bearings	12	Selection of fit	32
Thrust bearings	18	Recommended fits and tolerances	35
Track runner bearings	19	Dimensional, form and running accuracy requirements	35
Y-bearings	21	Surface roughness of bearing seats	36
Designation system for rolling bearings	22	Axial location of bearings	37
Basic designations	22	Abutment and fillet dimensions	38
Designation suffixes	24	Sealing arrangements	39
Identifying SKF products	26	External seals	39
Bearing identification	26	Integral bearing sealing solutions	40
Split housing and bearing unit identification	27	Storage of bearings, seals and lubricants	41
Replacement seals	27	Storage of bearings, bearing units and housings	41
Bearing life	27	Storage of elastomer seals	42
Basic rating life	27	Storage of lubricants	42
SKF rating life	27	Lubricant disposal	43
Service life	28		
Bearing service life	28		
Seal service life	28		
Lubricant service life	28		
Cleanliness	28		
Bearing internal clearance	29		
Bearing arrangements	30		
Types of bearing arrangements	30		
Locating and non-locating bearing arrangements	30		
Adjusted bearing arrangements	31		

Terminology

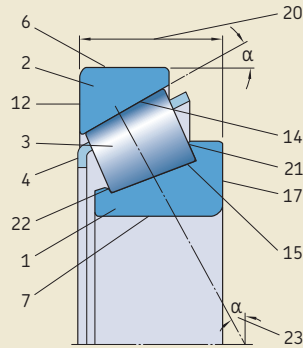
Bearings (→ fig. 1)

- 1 Inner ring
- 2 Outer ring
- 3 Rolling element: ball, cylindrical roller, needle roller, tapered roller, spherical roller, toroidal roller
- 4 Cage
- 5 Capping device
Seal – made of elastomer, contact (shown in figure) or non-contact
Shield – made of sheet steel, non-contact
- 6 Outer ring outside diameter
- 7 Inner ring bore
- 8 Inner ring shoulder diameter
- 9 Outer ring shoulder diameter
- 10 Snap ring groove
- 11 Snap ring
- 12 Outer ring side face
- 13 Anchor recess for capping device
- 14 Outer ring raceway
- 15 Inner ring raceway
- 16 Recess for capping device
- 17 Inner ring side face
- 18 Chamfer
- 19 Bearing pitch circle diameter
- 20 Total bearing width
- 21 Guide flange
- 22 Retaining flange
- 23 Contact angle
- 24 Shaft washer
- 25 Rolling element and cage assembly
- 26 Housing washer
- 27 Housing washer with sphered seat surface
- 28 Seat washer

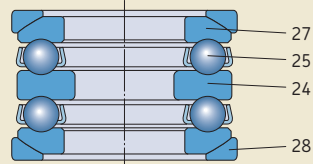
Fig. 1



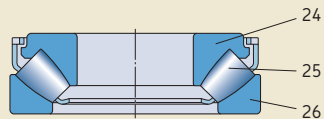
Deep groove ball bearing



Tapered roller bearing



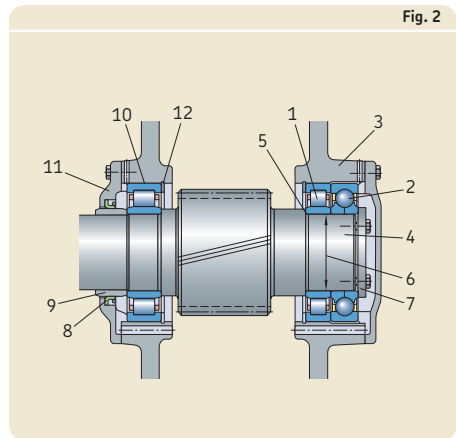
Double direction thrust ball bearing



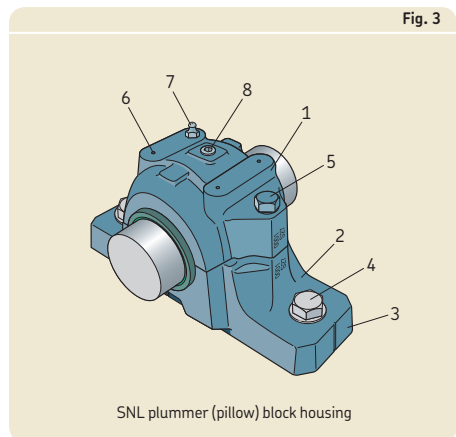
Spherical roller thrust bearing

Bearing arrangements (→ fig. 2)

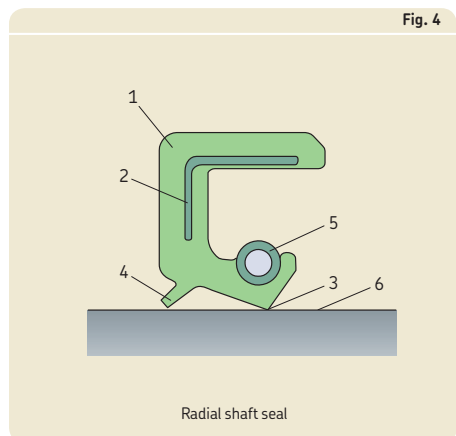
- 1 Cylindrical roller bearing
- 2 Four-point contact ball bearing
- 3 Housing
- 4 Shaft
- 5 Shaft abutment shoulder
- 6 Shaft diameter
- 7 Locking plate
- 8 Radial shaft seal
- 9 Distance ring
- 10 Housing bore
- 11 Housing cover
- 12 Snap ring

**Housings (→ fig. 3)**

- 1 Housing cap
- 2 Housing base
- 3 Housing foot
- 4 Attachment bolt
- 5 Cap bolt
- 6 Dimple
- 7 Grease fitting
- 8 Hole for eye bolt

**Seals (→ fig. 4)**

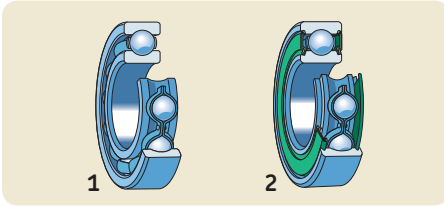
- 1 Rubber shell
- 2 Sheet steel reinforcement
- 3 Seal lip
- 4 Auxiliary seal lip
- 5 Garter spring
- 6 Seal counterface



Rolling bearing types and designs

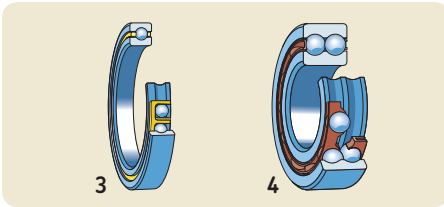
This section gives a summary of the different standard bearing types and designs. Most are illustrated.

Radial bearings

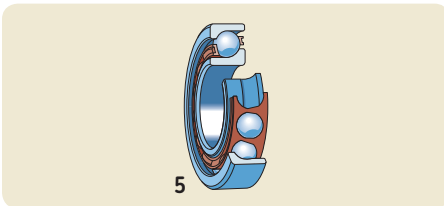


Deep groove ball bearings

single row, with or without filling slots
open basic design (1)
with shields
with contact seals (2)
with a snap ring groove, with or without a snap ring

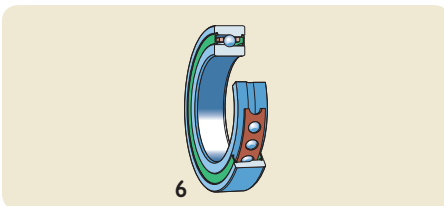


single row with a fixed section
open basic design (3)
with contact seals
double row (4)

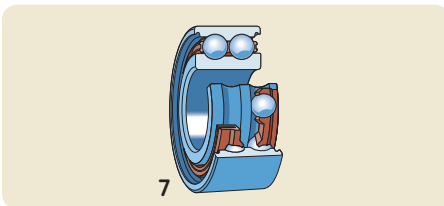


Angular contact ball bearings

single row
basic design for single mounting
design for universal matching (5)

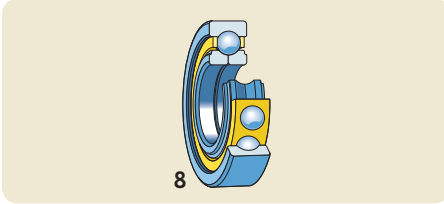


single row high- and super-precision
open basic design
with contact seals
open high-speed design
with contact seals (6)
open high-capacity design
with contact seals

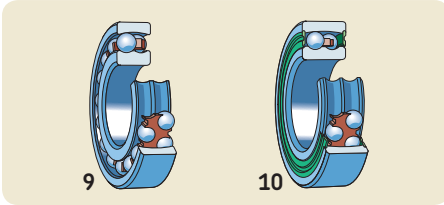


double row
with a one-piece inner ring (7)
open basic design
with shields
with contact seals
with a two-piece inner ring

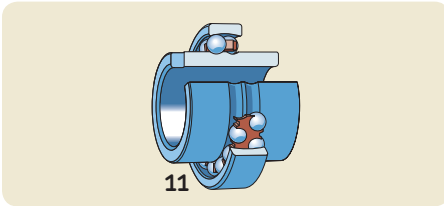
Radial bearings



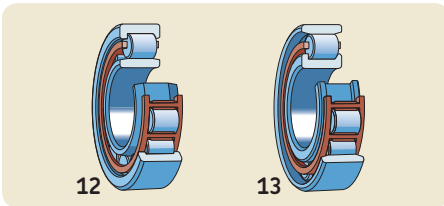
Four-point contact ball bearings (8)



Self-aligning ball bearings
with a cylindrical or tapered bore
open basic design (9)
with contact seals (10)

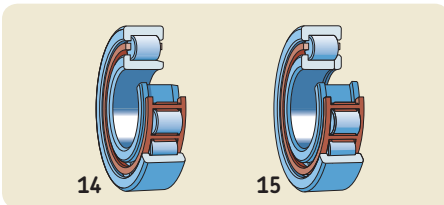


with an extended inner ring (11)



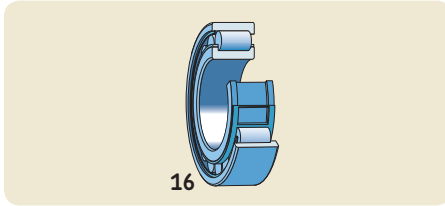
Cylindrical roller bearings

single row
NU design (12)
with angle ring
N design (13)

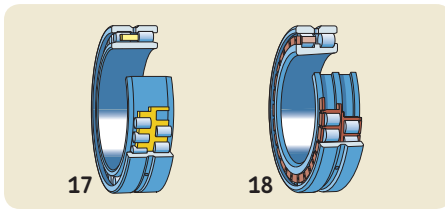


single row
NJ design (14)
with angle ring
NUP design (15)

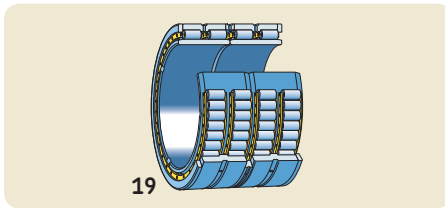
Radial bearings



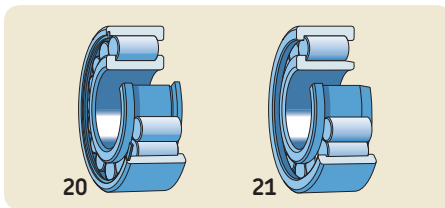
Cylindrical roller bearings
single row
high-capacity NCF design (16)



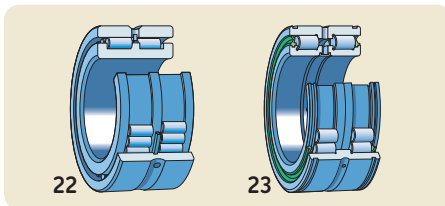
double row
with a cylindrical or tapered bore
NNU design (17)
NN design (18)
NNUP design



four-row
with a cylindrical or tapered bore
open design (19)
with contact seals

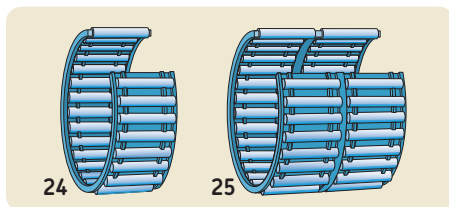


Full complement cylindrical roller bearings
single row
NCF design (20)
NJG design (21)



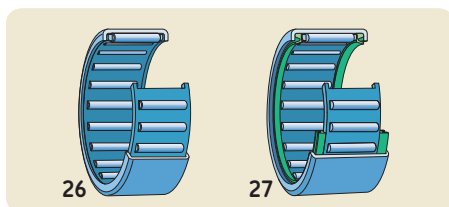
double row
with integral flanges on the inner ring (22)
with integral flanges on the inner and
outer rings
with contact seals (23)

Radial bearings



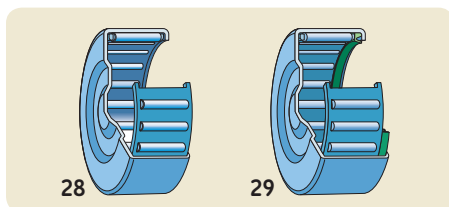
Needle roller and cage assemblies

single row (24)
double row (25)



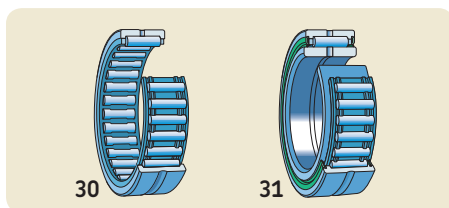
Drawn cup needle roller bearings, open ends

single and double row
open basic design (26)
with contact seals (27)



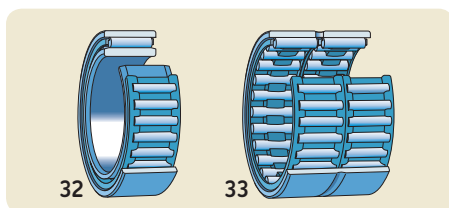
Drawn cup needle roller bearings, closed end

single and double row
open basic design (28)
with a contact seal (29)



Needle roller bearings with flanges

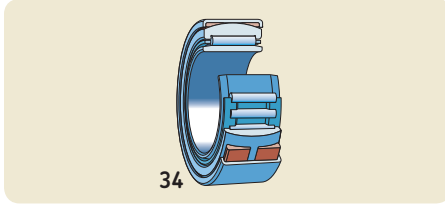
single and double row
without an inner ring (30)
with an inner ring
open basic design
with contact seals (31)



Needle roller bearings without flanges

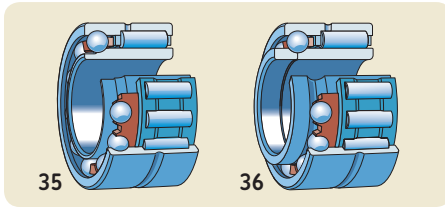
single and double row
with an inner ring (32)
without an inner ring (33)

Radial bearings



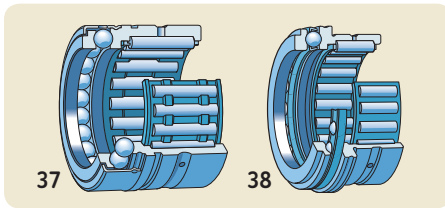
Alignment needle roller bearings

without an inner ring
with an inner ring (34)

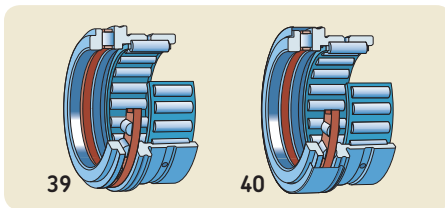


Combined needle roller bearings

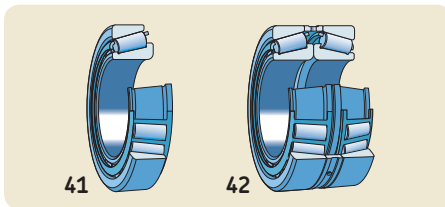
Needle roller / angular contact ball bearings
single direction (35)
double direction (36)



Needle roller / thrust ball bearings
with a full complement thrust ball bearing (37)
with a cage-guided ball set
with or without (38) a cover



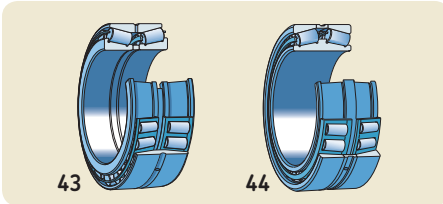
Needle roller / cylindrical roller thrust bearings
without a cover (39)
with a cover (40)



Tapered roller bearings

single row
single bearings (41)
matched bearing sets
face-to-face (42)
back-to-back
tandem

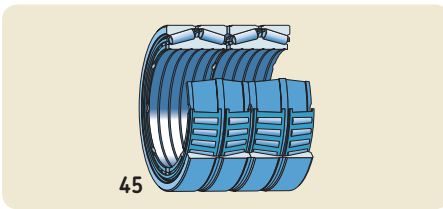
Radial bearings



double row

TDO configuration (back-to-back) (43)

TDI configuration (face-to-face) (44)



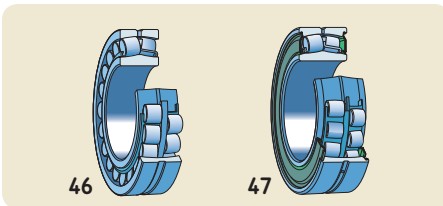
four-row

TQO configuration open design

open design (45)

with contact seals

TQI configuration



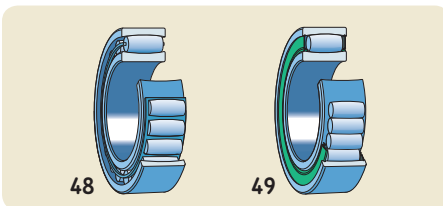
Spherical roller bearings

with a cylindrical or tapered bore

open basic designs (46)

with contact seals (47)

for vibratory applications



CARB toroidal roller bearings

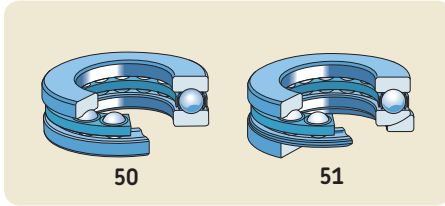
with a cylindrical or tapered bore

with a cage-guided roller set (48)

with a full complement roller set

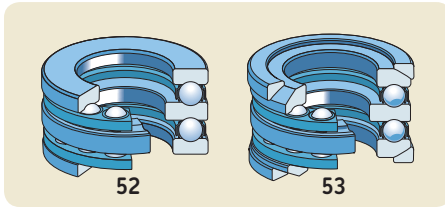
with contact seals (49)

Thrust bearings

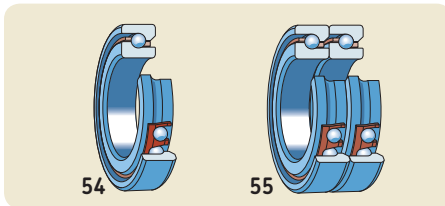


Thrust ball bearings

single direction
with a flat housing washer (50)
with a sphered housing washer
with (51) or without a seat washer

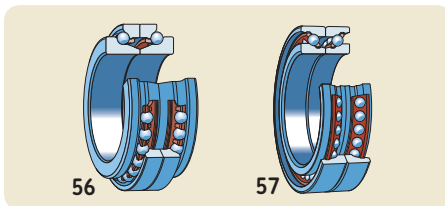


double direction
with flat housing washers (52)
with sphered housing washers
with (53) or without seat washers

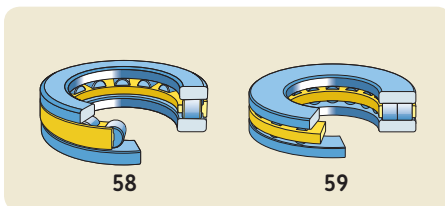


Angular contact thrust ball bearings

high- and super-precision bearings
single direction
basic design for single mounting (54)
design for universal matching
matched bearing sets (55)



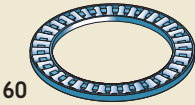
double direction
basic design (56)
high-speed design (57)



Cylindrical roller thrust bearings

single direction
single row (58)
double row (59)
components
cylindrical roller and cage thrust assemblies
shaft and housing washers

Thrust bearings



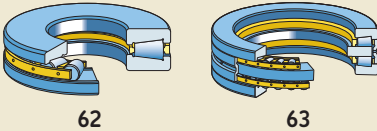
Needle roller thrust bearings

single direction
 needle roller and cage thrust assemblies (60)
 raceway washers
 thrust washers



Spherical roller thrust bearings

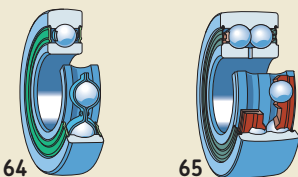
single direction (61)



Tapered roller thrust bearings

single direction
 with or without (62) a cover
 screw down bearings
 double direction (63)

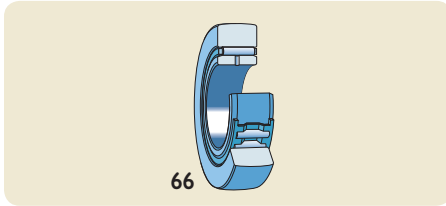
Track runner bearings



Cam rollers

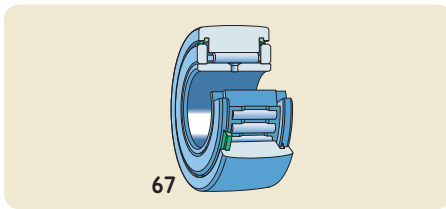
single row cam roller (64)
 double row cam roller (65)

Track runner bearings

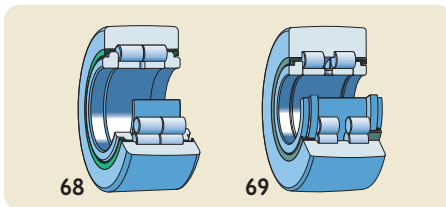


Support rollers

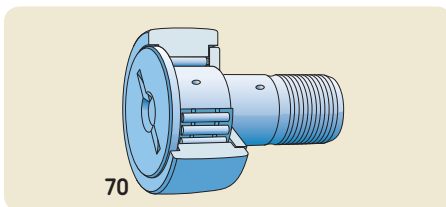
- with a needle roller and cage assembly, without axial guidance
 - with or without contact seals
 - without an inner ring
 - with an inner ring (**66**)



- with needle rollers, with thrust washers for axial guidance
 - with or without contact seals
 - with a needle roller and cage assembly (**67**)
 - with a full complement roller set

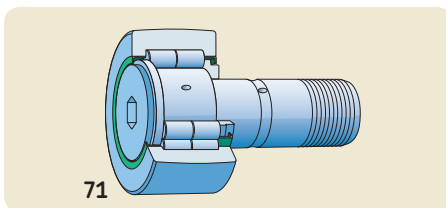


- with a full complement of cylindrical rollers, axially guided by flanges
 - with labyrinth seals (**68**)
 - with contact seals (**69**)
 - with lamellar seals



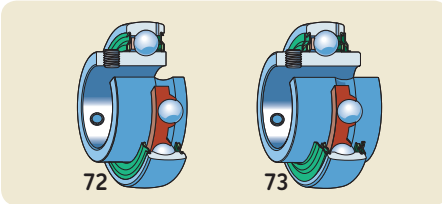
Cam followers

- with needle rollers, axially guided by the stud, thrust plate and roller flanges
 - with or without contact seals
 - with a concentric seat (**70**)
 - with an eccentric seat collar
 - with a needle roller and cage assembly (**70**)
 - with a full complement of needle rollers



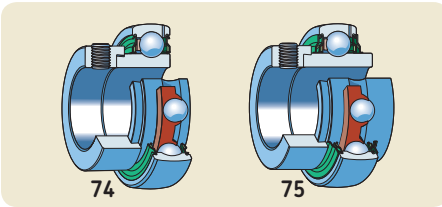
- with a full complement of cylindrical rollers, axially guided by the stud, flange ring and roller flanges
 - with labyrinth seals (**71**)
 - with contact seals
 - with a concentric seat (**71**)
 - with an eccentric seat collar

Y-bearings

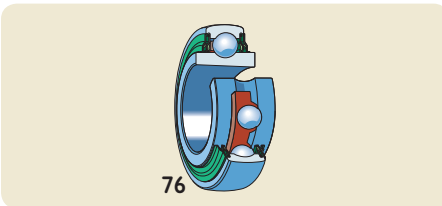


Y-bearings (insert bearings)

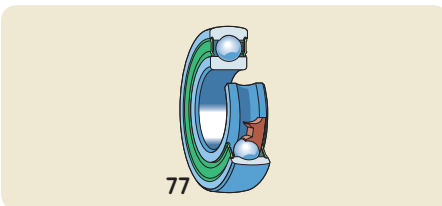
with grub (set) screws
 inner ring extended on one side (72)
 inner ring extended on both sides (73)



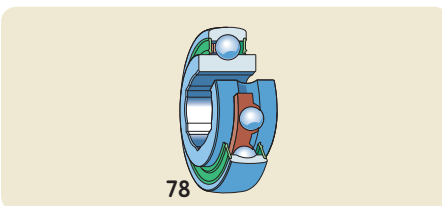
with an eccentric locking collar
 inner ring extended on one side (74)
 inner ring extended on both sides (75)



with a tapered bore
 inner ring extended on both sides (76)
 for adapter sleeve mounting



with a standard inner ring
 located on the shaft with an interference
 fit (77)



with a hexagonal bore
 inner ring extended on both sides (78)

Designation system for rolling bearings

Basic designations

All SKF standard bearings have a characteristic basic designation, which generally consists of three, four or five figures or a combination of letters and figures. The design of the system used for almost all standard ball and roller bearing types is shown schematically in **diagram 1**. The figures and combinations of letters and figures have the following meaning:

- The first figure or the first letter or combination of letters identifies the bearing type and eventually a basic variant.
- The following two figures identify the ISO dimension series; the first figure indicates the width or height series (dimensions B, T or H) and the second the diameter series (dimension D).
- The last two figures of the basic designation give the size code of the bearing; when multiplied by 5, the bore diameter in millimetres is obtained.

The most important exceptions to the basic bearing designation system are listed here.

- 1 In a few cases, the figure for the bearing type or the first figure of the dimension series identification is omitted. These figures are shown in brackets in **diagram 1**.
- 2 Bearings with bore diameters of 10, 12, 15 or 17 mm have the following size code identifications:
 - 00 = 10 mm
 - 01 = 12 mm
 - 02 = 15 mm
 - 03 = 17 mm
- 3 For bearings having a bore diameter smaller than 10 mm, or 500 mm and larger, the bore diameter is generally given in millimetres and is not coded. The size identification is separated from the rest of the bearing designation by an oblique stroke, e.g. 618/8 (d = 8 mm) or 511/530 (d = 530 mm). This is also true of standard bearings in accordance with ISO 15:1998 that have bore diameters of 22, 28 or 32 mm, e.g. 62/22 (d = 22 mm).

- 4 For some small bearings having a bore diameter smaller than 10 mm, such as deep groove, self-aligning and angular contact ball bearings, the bore diameter is also given in millimetres (uncoded) but is not separated from the series designation by an oblique stroke, e.g. 629, 129 or 709 (d = 9 mm).
- 5 Bore diameters that deviate from standard bore diameters are uncoded and given in millimetres up to three decimal places. This bore diameter identification is part of the basic designation and is separated from the basic designation by an oblique stroke, e.g. 6202/15.875 (6202 bearing with a special bore d = 15,875 mm = 5/8 in.).

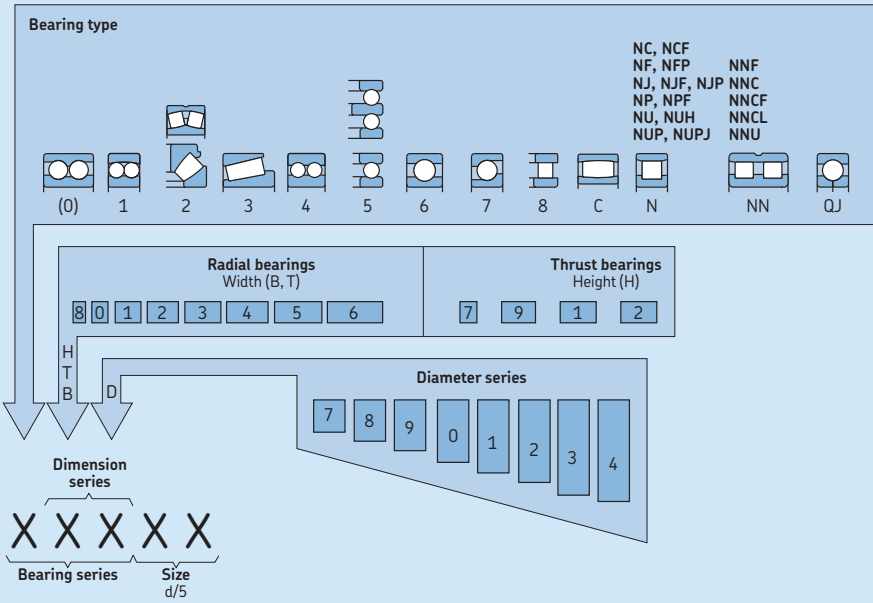
Series designations

Each standard bearing belongs to a given bearing series, which is identified by the basic designation without the size identification. Series designations often include a suffix A, B, C, D or E or a combination of these letters, e.g. CA. These are used to identify differences in internal design, e.g. contact angle.

The most common bearing series designations are shown in **diagram 1**, above the bearing sketches. The figures in brackets are omitted in the series designation.

Designation system for SKF standard metric ball and roller bearings

Bearing series													
				6(0)4									
				544	623					(0)4			
		223		524	6(0)3					33			
		213		543	622					23			
		232		523	6(0)2					(0)3			
		222		542	630			23		32			
		241		522	6(1)0					22			
		231			16(0)0					41			(0)2
		240	323	534	639					31	31		41
		230	313	514	619					60	30		31
		249	303	533	609					50	20		60
	139	239	332	513	638	7(0)4	814	40	10	40	10		50
	130	248	322	532	628	7(0)3	894	30	39	40	39		40
	(1)23	238	302	512	618	7(0)2	874	69	29	30	29		30
	1(0)3		331	511	608	7(1)0	813	59	19	69	19		69
	(1)22		294	330	510	637	719	893	49	38	49		38
(0)33	1(0)2		293	320	4(2)3	591	627	718	812	39	28		39
(0)32	1(1)0		292	329	4(2)2	590	617	708	811	29	18		48
													19



Code	Bearing type	Code	Bearing type	Code	Bearing type
0	Double row angular contact ball bearing	7	Single row angular contact ball bearing	QJ	Four-point contact ball bearing
1	Self-aligning ball bearing	8	Cylindrical roller thrust bearing	T	Tapered roller bearing in accordance with ISO 355-2007
2	Spherical roller bearing, spherical roller thrust bearing	C	CARB toroidal roller bearing		
3	Tapered roller bearing	N	Cylindrical roller bearing. Two or more letters are used to identify the number of the rows or the configuration of the flanges, e.g. NJ, NU, NUP, NN, NNU, NNCF etc.		
4	Double row deep groove ball bearing				
5	Thrust ball bearing				
6	Single row deep groove ball bearing				

Designation suffixes

Designation suffixes are used to identify designs, variants or features that differ from the original or current standard bearing. Some of the most commonly used designation suffixes are listed here.

- CN** Normal internal clearance, normally only used together with an additional letter that identifies a reduced or displaced clearance range
- CS** Sheet steel reinforced contact seal of acrylonitrile-butadiene rubber (NBR) on one side of the bearing
- 2CS** CS contact seal on both sides of the bearing
- CS2** Sheet steel reinforced contact seal of fluoro rubber (FKM) on one side of the bearing
- 2CS2** CS2 contact seal on both sides of the bearing
- CS5** Sheet steel reinforced contact seal of hydrogenated acrylonitrile-butadiene rubber (HNBR) on one side of the bearing
- 2CS5** CS5 contact seal on both sides of the bearing
- C1** Bearing internal clearance smaller than C2
- C2** Bearing internal clearance smaller than Normal (CN)
- C3** Bearing internal clearance greater than Normal (CN)
- C4** Bearing internal clearance greater than C3
- C5** Bearing internal clearance greater than C4
- F** Machined steel or special cast iron cage, rolling element centred
- FA** Machined steel or special cast iron cage, outer ring centred
- FB** Machined steel or special cast iron cage, inner ring centred
- G..** Grease fill. A second letter indicates the temperature range of the grease and a third letter identifies the actual grease. A figure following the three-letter grease code indicates that the filling degree deviates from the standard: Figures 1, 2 and 3 indicate a smaller fill than standard, 4 up to 9 a larger fill.
- H** Stamped snap-type steel cage, hardened

- HT** Grease fill for high temperatures. HT or a two-digit number following HT identifies the actual grease. Filling degrees other than standard are identified by a letter or letter/figure combination following HTxx.
- J** Stamped steel cage, rolling element centred, unhardened
- K** Tapered bore, taper 1:12
- K30** Tapered bore, taper 1:30
- LHT** Grease fill for low and high temperatures. LHT or a two-digit number following LHT identifies the actual grease. Filling degrees other than standard are identified by a letter or letter/figure combination following LHTxx.
- LS** Contact seal of acrylonitrile-butadiene rubber (NBR) or polyurethane (AU) with or without sheet steel reinforcement, on one side of the bearing
- 2LS** LS contact seal on both sides of the bearing
- LT** Grease fill for low temperatures. LT or a two-digit number following LT identifies the actual grease. Filling degrees other than standard are identified by a letter or letter/figure combination following LTxx.
- M** Machined brass cage, rolling element centred
- MA** Machined brass cage, outer ring centred
- MB** Machined brass cage, inner ring centred
- ML** Machined one-piece window-type brass cage, inner or outer ring centred
- MT** Grease fill for medium temperatures. MT or a two-digit number following MT identifies the actual grease. Filling degrees other than standard are identified by a letter or letter/figure combination following MTxx.
- N** Snap ring groove in the outer ring
- NR** Snap ring groove in the outer ring with the appropriate snap ring
- P** Injection moulded cage of glass fibre reinforced polyamide 66 (PA66), rolling element centred
- PHA** Injection moulded cage of glass fibre reinforced polyetheretherketone (PEEK), outer ring centred
- RS** Contact seal of acrylonitrile-butadiene rubber (NBR) with or without sheet steel reinforcement on one side of the bearing

2RS	RS contact seal on both sides of the bearing
RSH	Sheet steel reinforced contact seal of acrylonitrile-butadiene rubber (NBR) on one side of the bearing
2RSH	RSH contact seal on both sides of the bearing
RSL	Sheet steel reinforced low-friction contact seal of acrylonitrile-butadiene rubber (NBR) on one side of the bearing
2RSL	RSL low-friction contact seal on both sides of the bearing
RS1	Sheet steel reinforced contact seal of acrylonitrile-butadiene rubber (NBR) on one side of the bearing
2RS1	RS1 contact seal on both sides of the bearing
RS1Z	Sheet steel reinforced contact seal of acrylonitrile-butadiene rubber (NBR) on one side and one shield on the other side of the bearing
RS2	Sheet steel reinforced contact seal of fluoro rubber (FKM) on one side of the bearing
2RS2	RS2 contact seal on both sides of the bearing
RZ	Sheet steel reinforced non-contact seal of acrylonitrile-butadiene rubber (NBR) on one side of the bearing
2RZ	RZ non-contact seal on both sides of the bearing
TN	Injection moulded cage of polyamide 66 (PA66), rolling element centred
TNH	Injection moulded cage of glass fibre reinforced polyetheretherketone (PEEK), rolling element centred
TN9	Injection moulded cage of glass fibre reinforced polyamide 66 (PA66), rolling element centred
V	Full complement bearing (without cage)
WT	Grease fill for low as well as high temperatures. WT or a two-digit number following WT identifies the actual grease. Filling degrees other than standard are identified by a letter or letter/figure combination following WTxx.
W64	Solid Oil filling
Y	Stamped brass cage, rolling element centred
Z	Shield of pressed sheet steel on one side of the bearing
2Z	Z shield on both sides of the bearing

Identifying SKF products

Bearing identification

NOTE: To be sure you are buying a genuine SKF bearing, purchase only from SKF or SKF Authorized Distributors.

Almost all SKF bearings are marked with the following identifiers on the inner or outer ring side faces (→ fig. 5):

- 1 SKF trademark
- 2 Complete bearing designation
- 3 Date of manufacture, coded
- 4 Country of manufacture

The type of bearing and its features can be identified from its designation. Other identifiers, depending on the bearing type, may also be present on the bearing.

NOTE: Sometimes, only part of the information is found on one ring. For example, the outer ring of a cylindrical roller bearing with roller and cage assembly might have the identification 3NU20 or 320 E. This identifies an outer ring of diameter series 3 for a 100 mm bore (20 × 5). This outer ring can be matched with a NU, NJ or NUP inner ring to form a complete bearing. In this case, the complete bearing designation should be found on the inner ring, e.g. NJ 320 ECP/C3. The complete designation is always printed on the package and is most often obtainable from machine drawings and equipment specifications.



Fig. 5

If the designation marked on the bearing is no longer legible, the basic bearing designation can generally be identified by measuring the boundary dimensions (→ fig. 6) and using the information, available online at www.skf.com/bearings.

- 1 Identify the bearing type (→ *Rolling bearing types and designs*, page 12).
- 2 Measure the bore d of the bearing.
- 3 Measure the outside diameter D of the bearing.
- 4 Measure the widths B , C , T or height H of the bearing.

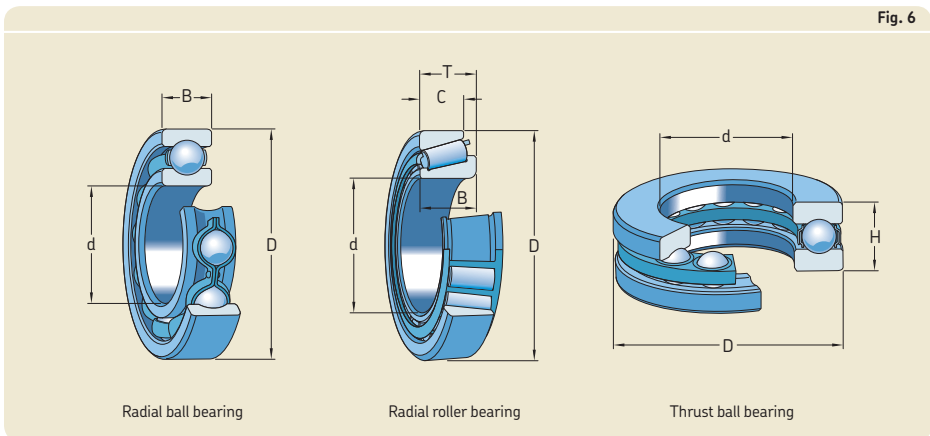


Fig. 6

- 5 Using the Detailed search functionality, available online at www.skf.com/bearings, enter the boundary dimensions, to identify the possible basic bearing designation.

NOTE: To determine the complete bearing designation, identify the cage type and material, the design of the seal, and any other visible features. For additional support, contact your SKF Authorized Distributor or the SKF Application engineering service.

Split housing and bearing unit identification

All SNL, SONL and SAF split plummer (pillow) block housings have their designations cast into the housing cap (→ **fig. 7**). The cap and base of each housing are marked with a unique serial number to prevent mixing components when mounting several housings in one session.

For bearing units, identify the bearing and housing (and other components where applicable) separately.

Replacement seals

Replacement seals should correspond in design and material to the original. Seals made of a different material than the original should only be used if absolutely necessary.

CAUTION: When replacing a seal, check the old seal's part number carefully. A simple error, like using a standard nitrile rubber seal to replace an identical, more resistant fluoro rubber seal, can result in sudden "mysterious" seal failure.

Bearing life

Basic rating life

The life of a rolling bearing is defined as the number of revolutions or the number of operating hours at a given speed that the bearing can endure before the first sign of fatigue occurs on one of its rings or rolling elements. This life can be calculated as a function of the bearing type, load and speed, using the basic rating life equation



Fig. 7

$$L_{10} = \left(\frac{C}{P}\right)^p$$

or, if the speed is constant

$$L_{10h} = \frac{10^6}{60 n} L_{10}$$

where

L_{10} = basic rating life (at 90% reliability)
[millions of revolutions]

L_{10h} = basic rating life (at 90% reliability)
[operating hours]

C = basic dynamic load rating [kN]

P = equivalent dynamic bearing load [kN]

n = rotational speed [r/min]

p = exponent of the life equation

= 3 for ball bearings

= 10/3 for roller bearings

SKF rating life

For modern high quality bearings, the basic rating life can deviate significantly from the actual service life in a given application. Therefore, ISO 281: 2007 contains a modified life equation to supplement the basic rating life.

Basics

The equation for SKF rating life is

$$L_{nm} = a_1 a_{SKF} L_{10} = a_1 a_{SKF} \left(\frac{C}{P} \right)^p$$

or, if the speed is constant

$$L_{nmh} = \frac{10^6}{60 n} L_{nm}$$

where

L_{nm} = SKF rating life (at 100 – n¹) % reliability)
[millions of revolutions]

L_{nmh} = SKF rating life (at 100 – n¹) % reliability)
[operating hours]

L_{10} = basic rating life (at 90% reliability)
[millions of revolutions]

a_1 = life adjustment factor for reliability

a_{SKF} = SKF life modification factor

C = basic dynamic load rating [kN]

P = equivalent dynamic bearing load [kN]

n = rotational speed [r/min]

p = exponent of the life equation
= 3 for ball bearings
= 10/3 for roller bearings

For additional information about how to calculate SKF rating life, visit www.skf.com/bearings.

Service life

Bearing service life

When calculating basic bearing life, the result can deviate significantly from the service life in a given application. Service life, which is the actual life of a bearing under real operating conditions until it fails (becomes unserviceable), depends on a variety of influencing factors including lubrication, the level of contamination within the bearing environment, misalignment, proper installation, and operating conditions such as loads, speed, temperature, and vibration levels. To take these influencing factors into account, SKF strongly recommends calculating the SKF rating life, and not just the basic rating life.

Seal service life

Seals are used to keep lubricant in and contaminants out of the bearing. In doing so, seals also protect the lubricant from contaminants, which ultimately helps the bearing achieve maximum service life.

Unlike bearings, seal life cannot be calculated. Seal service life is even harder to predict because it is almost entirely dependent on the operating conditions, as well as the level of contamination within the environment, shaft alignment, installation procedures and exposure to harsh chemicals like cleaning agents.

Lubricant service life

In virtually every application, the lubricant has a significant impact on bearing service life. Therefore, all lubricants should be matched to the operating conditions of the application. Whether a bearing in an arrangement is lubricated with grease or oil, the effectiveness of the lubricant will deteriorate over time due to mechanical working, ageing, and the build-up of contaminants resulting from component wear and/or ingress of contaminants. As a result, the actual service life of a lubricant is difficult to predict. However, SKF provides guidelines for relubrication intervals and maintenance procedures later in this publication.

Cleanliness

Contamination can adversely affect bearing and seal service life. It also can have a negative influence on the service life of the lubricant. Therefore, it is important that rolling bearings are lubricated with clean grease or oil and that the lubricant is fully protected from contaminants by an effective sealing system.

Cleanliness should be observed during all maintenance activities from mounting and relubrication to inspection and dismounting. Detailed recommendations regarding cleanliness are provided later in the relevant chapters, but some general guidelines are provided here:

¹⁾ The factor n represents the failure probability, i.e. the difference between the requisite reliability and 100%.

Fig. 8

1

- Keep bearings in their original package, where they are well protected, until immediately before mounting.
- Mount bearings in an area that is free from dirt, dust and moisture.
- Use professional tools for all maintenance activities.
- Clean up grease and oil spills immediately.
- Clean grease fittings prior to relubrication and close them properly with a suitable grease fitting cap.
- Use properly identified and clean containers to transport and supply lubricant. The use of a separate container for each type of lubricant is a good practice and strongly advised.
- For routine washdowns, direct the hose away from the seals.

NOTE: It is better to prevent bearings from becoming dirty than to clean them. Many bearing types cannot be separated and are therefore difficult to clean.

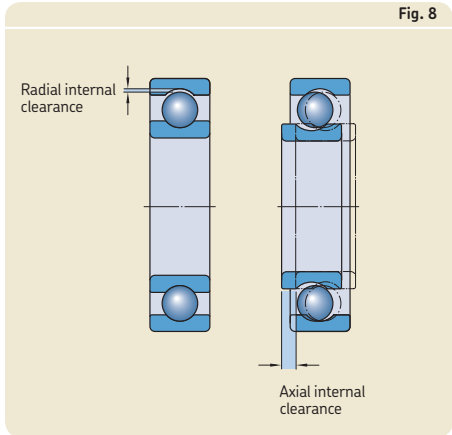
Bearing internal clearance

Bearing internal clearance is defined as the total distance through which one bearing ring can be moved relative to the other (→ fig. 8):

- in the radial direction (radial internal clearance)
- in the axial direction (axial internal clearance)

It is necessary to distinguish between the internal clearance of a bearing before mounting (→ Appendix E, starting on page 388) and the internal clearance in a mounted bearing that has reached its operating temperature (operational clearance). The initial internal clearance (before mounting) is greater than the operational clearance because different degrees of interference in the fits and differences in thermal expansion of the bearing rings and the associated components cause the rings to be expanded or compressed.

The radial internal clearance of a bearing is of considerable importance to achieve satisfactory operation. As a general rule:



- Ball bearings should always have an operational clearance that is virtually zero, or there may be a slight preload.
- Cylindrical, spherical and CARB toroidal roller bearings should always have some residual clearance during operation.
- Tapered roller bearings should always have some residual clearance, except in bearing arrangements where stiffness is desired, such as pinon bearing arrangements where the bearings are mounted with a certain amount of preload.

NOTE: Where operating and mounting conditions differ from the normal, e.g. where interference fits are used for both bearing rings or unusual temperatures prevail, bearings with greater or smaller internal clearance than Normal may be required. In these cases, SKF recommends checking residual clearance in the bearing after it has been mounted.

Bearing arrangements

Generally, two bearings are required to support a rotating machine component, with the typical arrangement comprising one locating and one non-locating bearing position. In some applications, both bearings share the responsibility to locate the shaft axially. These are called adjusted or cross-located bearing arrangements.

Types of bearing arrangements

Locating and non-locating bearing arrangements

Arrangements with a locating and non-locating bearing are most common (→ **fig. 9**).

The bearing in the locating position, which is typically positioned at the drive end of a machine, supports the shaft radially and locates it axially in both directions. It must, therefore, be fixed in position both on the shaft and in the housing. Suitable bearing types for the locating position include:

- deep groove ball bearings (→ **fig. 9**)
- self-aligning ball bearings
- spherical roller bearings (→ **fig. 10**, left)
- double row or paired single row angular contact ball bearings
- matched tapered roller bearings
- cylindrical roller bearings (NJ and HJ, and NUP design bearings)

Combinations of a radial bearing that can accommodate a purely radial load and a bearing that takes the thrust load can also be used, e.g. an NU design cylindrical roller bearing and a four-point contact ball bearing (→ **fig. 11**).

The bearing in the non-locating position provides radial support and if needed, accommodates axial displacement of the shaft, relative to the housing, as a result of thermal expansion. Some bearings can take axial displacement within the bearing. Typical bearing types with this capability include:

- CARB toroidal roller bearings
- cylindrical roller bearings with flanges on one ring only, i.e. N and NU design bearings

For other bearings in the non-locating position, axial displacement takes place between one of

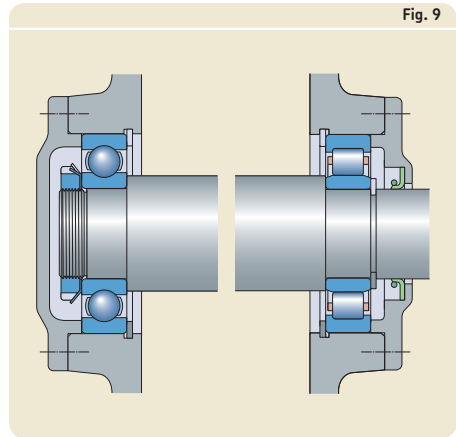


Fig. 9

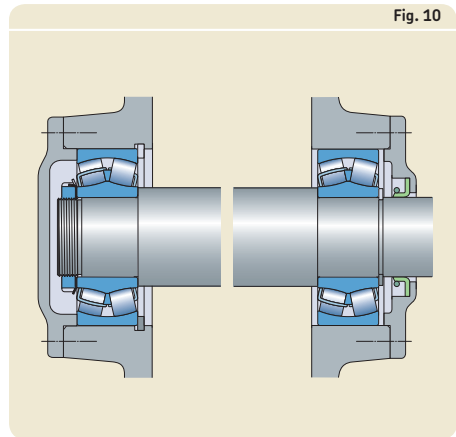


Fig. 10

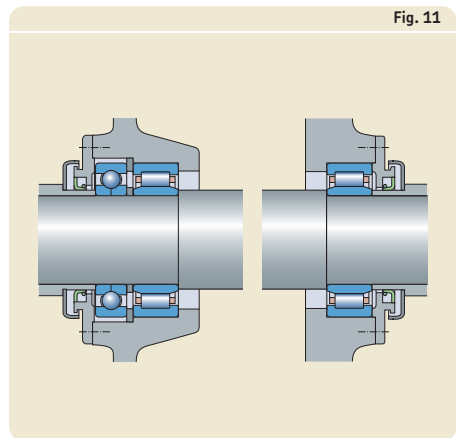


Fig. 11

the bearing rings and its seat, typically between the outer ring and the housing bore. Suitable bearing types for the non-locating position include:

- deep groove ball bearings
- self-aligning ball bearings
- spherical roller bearings (→ fig. 10, right)

Adjusted bearing arrangements

In an adjusted bearing arrangement, the shaft is located axially in one direction by one bearing and in the opposite direction by the other bearing. This arrangement, also referred to as cross-locating, is generally used for short shafts. All kinds of radial ball and roller bearings that accommodate axial loads in at least one direction are suitable for cross-locating bearing arrangements, including:

- deep groove ball bearings
- angular contact ball bearings (→ fig. 12)
- tapered roller bearings

Methods of bearing location

Radial location of bearings

If the load carrying ability of a bearing is to be fully utilized, its rings or washers must be fully supported around their complete circumference and across the entire width of the raceway.

Generally, satisfactory radial location and adequate support can only be obtained when the rings are mounted with an appropriate degree of interference. Inadequately or incorrectly secured bearing rings generally cause damage to the bearings and associated components. In cases where an interference fit cannot be used and a loose fit is to be applied, special precautions are necessary to limit bearing creep, otherwise a worn bearing seat on the shaft or in the housing may result.

NOTE: Creep is the relative movement between a bearing ring and its seat, and typically occurs when there is an insufficient interference fit for the load conditions or when an interference fit cannot be applied.

Fig. 12

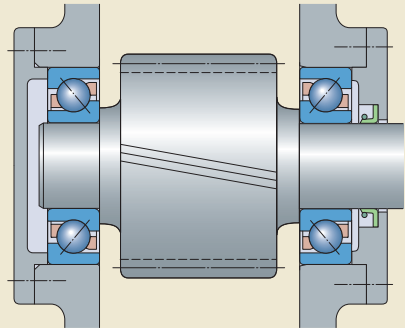
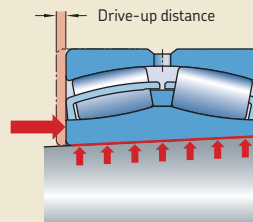


Fig. 13



Basics

Selection of fit

Bearings with a cylindrical bore

When selecting fits for bearings with a cylindrical bore, the first thing to consider is the conditions of rotation (→ **table 1**). Essentially, there are three different conditions:

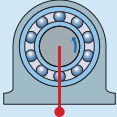
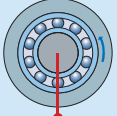
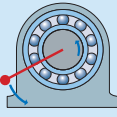
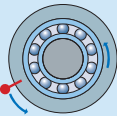
- Rotating load refers to a bearing ring that rotates while the direction of the applied load is stationary. (A rotating load can also refer to a bearing ring that is stationary, and the direction of the applied load rotates.)
- Stationary load refers to a bearing ring that is stationary while the direction of the applied load is also stationary. (A stationary load can also refer to a bearing ring that rotates at the same speed as the load.)
- Direction of load indeterminate refers to variable external loads, shock loads, vibrations and unbalance loads in high-speed machines.

Other factors to be taken into consideration when selecting fits are listed in **table 2**, on **pages 33 and 34**.

Bearings with a tapered bore

Bearings with a tapered bore are mounted either directly on a tapered shaft seat, or with an adapter or withdrawal sleeve on a cylindrical shaft seat. The inner ring fit is determined by how far the ring is driven up on the shaft seat or sleeve (→ **fig. 13, page 31**).

Table 1

Conditions of rotation and loading				
Operating conditions	Schematic illustration	Load condition	Example	Recommended fits
Rotating inner ring Stationary outer ring Constant load direction		Rotating load on inner ring Stationary load on outer ring	Belt-driven shafts	Interference fit for inner ring Loose fit for outer ring
Stationary inner ring Rotating outer ring Constant load direction		Stationary load on inner ring Rotating load on outer ring	Conveyor idlers Car wheel hub bearings	Loose fit for inner ring Interference fit for outer ring
Rotating inner ring Stationary outer ring Load rotates with inner ring		Stationary load on inner ring Rotating load on outer ring	Vibratory applications Vibrating screens or motors	Interference fit for outer ring Loose fit for inner ring
Stationary inner ring Rotating outer ring Load rotates with outer ring		Rotating load on inner ring Stationary load on outer ring	Gyratory crusher (Merry-go-round drives)	Interference fit for inner ring Loose fit for outer ring

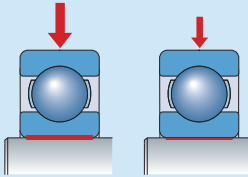
Factors to consider when selecting fits

Factors

Situation

Guideline rules

Magnitude of load



Bearings subjected to heavy loads tend to creep more than those subjected to light loads.

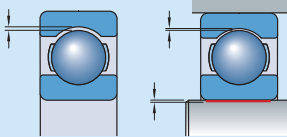
To prevent creep, select greater interference fits for bearings subjected to heavier loads.

Shock loads should also be considered.

Magnitude of load is defined as:

- $P \leq 0,05 C$ – light load
- $0,05 C < P \leq 0,1 C$ – normal load
- $0,1 C < P \leq 0,15 C$ – heavy load
- $P > 0,15 C$ – very heavy load

Bearing internal clearance



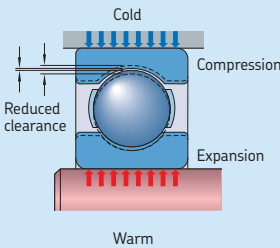
Clearance before mounting

Clearance after mounting

The tighter the interference fit, the bigger the reduction in the initial bearing internal clearance after mounting.

When tight fits are applied, bearings with radial internal clearance greater than Normal may be required.

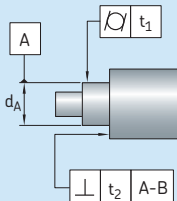
Temperature differences



The outer ring often has a lower temperature than the inner ring during operation, resulting in reduced internal clearance.

Depending on the (expected) operating temperatures of the components, bearings with radial internal clearance greater than Normal may be required.

Running accuracy requirements



Bearings with loose fits are susceptible to vibration when high demands are placed on running accuracy.

When high demands are placed on running accuracy, select fits corresponding to at least tolerance grade IT5 for the shaft and at least tolerance grade IT6 for the housing.

To reduce runout and vibration, select interference fits.

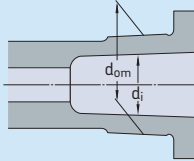
Factors to consider when selecting fits

Factors

Situation

Guideline rules

Design and material of shaft and housing



Fits might be less effective for hollow shafts or thin-walled housings.

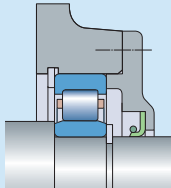
Select heavier than normal interference fits for bearings mounted in thin-walled or light-alloy housings, or on hollow shafts.

Poor contact on the bearing seat, e.g. in split housings, can distort the bearing ring, causing it to become out-of-round.

Split housings are not suitable for heavy interference fits. For these housings, SKF recommends tolerance group G or H (or at most, K).

The material of the bearing seat, if not made from bearing steel, will affect the fit selection, due to the different coefficients of thermal expansion.

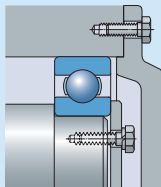
Ease of mounting and dismounting



Mounting and dismounting is easier for bearings with a clearance fit than for bearings with an interference fit.

If an interference fit is needed and easy mounting and dismounting is essential, select separable bearings or bearings with a tapered bore. Bearings with a tapered bore can be mounted either directly on a tapered shaft seat or on an adapter or withdrawal sleeve on a cylindrical shaft seat.

Displacement of the bearing in the non-locating position



Some bearings can accommodate axial displacement within the bearing, such as cylindrical roller bearings having one ring without flanges, needle roller bearings or CARB toroidal roller bearings.

Bearings that cannot accommodate axial displacement within the bearing should have one ring free, i.e. select a clearance fit for the ring carrying the stationary load.

Recommended fits and tolerances

The tolerances for the bore and outside diameter of rolling bearings are internationally standardized. To achieve a suitable fit, only a limited number of ISO tolerance classes need to be considered for the shaft and housing seats for rolling bearing applications. The location of the most commonly used tolerance classes relative to the bearing bore and outside diameter tolerances are illustrated in **fig. 14**.

NOTE: A letter and figure designate each ISO tolerance class. The letter (lower case for shaft diameters and upper case for housing bores) locates the tolerance zone relative to the nominal dimension. The figure provides the size of the tolerance zone.

Recommendations for bearing fits for solid steel shafts and for cast iron and steel housings are provided in **Appendix A**, starting on **page 334**. The appropriate values for the tolerances for rolling bearing seats on shafts and in housings are provided in **Appendix B**, starting on **page 338**.

If bearings are to be mounted with an interference fit on a hollow shaft, it is generally necessary to use a heavier interference fit than would be used for a solid shaft, in order to achieve

the same surface pressure between the inner ring and shaft seat. For additional information, visit www.skf.com/bearings.

Dimensional, form and running accuracy requirements

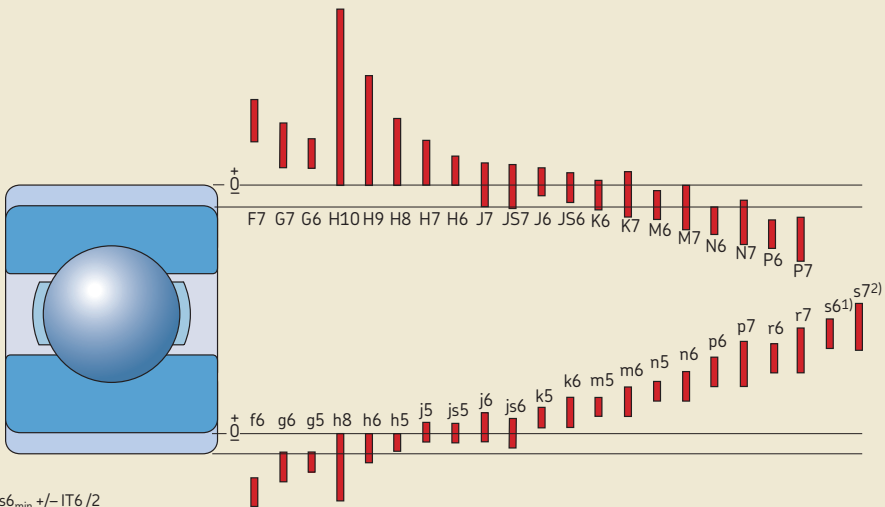
The accuracy of cylindrical bearing seats on shafts and in housing bores should correspond to the accuracy of the bearings used. SKF recommends the following guidelines for form and running accuracy when machining seats and abutments.

Dimensional accuracy

For bearings made to Normal tolerances, the dimensional accuracy of cylindrical seats on the shaft should be at least tolerance grade IT6. The dimensional accuracy of the housing should be at least tolerance grade IT7. Where adapter or withdrawal sleeves are used, a wider diameter tolerance (tolerance grade IT9) can be permitted than for bearing seats (→ **Appendix B-7, page 384**). The numerical values of standard tolerance grades IT are provided in **Appendix C, on page 385**.

For bearings with higher accuracy, correspondingly better grades should be used.

Fig. 14



Basics

Tolerances for cylindrical form

The cylindricity tolerance t_1 of a bearing seat should be one to two IT tolerance grades better than the prescribed dimensional tolerance, depending on the requirements. For example, if a bearing seat on a shaft has been machined to tolerance class m6, then the accuracy of form should be tolerance grade IT5 or IT4. The tolerance value t_1 for cylindricity is obtained for an assumed shaft diameter of 150 mm from $t_1 = IT5/2 = 18/2 = 9 \mu\text{m}$. However, the tolerance t_1 is for a radius, therefore $2 \times t_1$ applies for the shaft diameter.

Guideline values for the cylindrical form tolerance t_1 (and the total runout tolerance t_3) for bearing seats are provided in **Appendix D-1**, on **page 386**.

When bearings are to be mounted on adapter or withdrawal sleeves, the cylindricity of the sleeve seat be tolerance grade IT5/2 (for tolerance class h9) (→ **Appendix B-7**, **page 384**).

Tolerance for perpendicularity

Abutments for bearing rings should have a perpendicularity tolerance that is better by at least one IT tolerance grade than the diameter tolerance of the associated cylindrical seat. For thrust bearing washer seats, the perpendicularity tolerance should not exceed tolerance grade IT5.

Guideline values for the perpendicularity tolerance t_2 (and for the total axial runout t_4) are provided in **Appendix D-1**, on **page 386**.

Surface roughness of bearing seats

The roughness of bearing seat surfaces does not have the same degree of influence on bearing performance as the dimensional, form and running accuracies. However, the smoothness of the mating surfaces will have a direct effect on the accuracy of the interference fit. For bearing arrangements where a high level of accuracy is required, guideline values for the mean surface roughness R_a are provided in **Appendix D-2**, on **page 387**. These guideline values apply to ground seats.

NOTE: For fine turned seats, the roughness should be one or two grades higher than those of ground seats. For non-critical bearing arrangements, relatively high surface roughness is permissible.

Axial location of bearings

An interference fit alone is inadequate to axially locate a bearing ring. As a rule, a suitable means of axially securing the ring is needed.

For locating bearings, both bearing rings should be secured axially on both sides (→ **fig. 15**).

For non-locating bearings, axial location depends on the bearing design as follows:

- For non-separable bearings, the ring having the tighter fit (usually the inner ring) should be secured axially; the outer ring being free to move axially on its seat (→ **fig. 16**).
- For separable bearings, e.g. cylindrical roller bearings, both rings should be secured axially (→ **fig. 17**).
- For CARB toroidal roller bearings, both rings should be secured axially.

For adjusted (cross-located) bearing arrangements, each bearing ring needs only be secured axially on one side (→ **fig. 18**).

Fig. 15

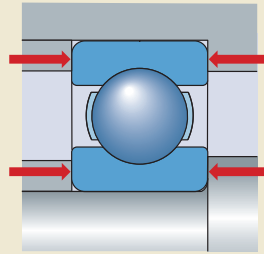


Fig. 16

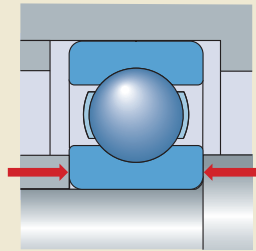


Fig. 18

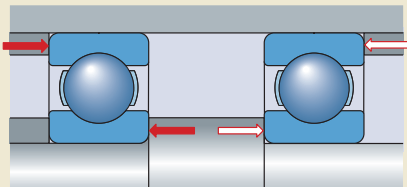
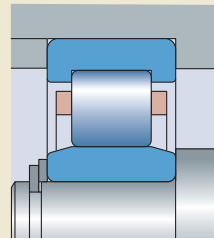


Fig. 17



Abutment and fillet dimensions

The dimensions of shaft and housing shoulders, spacer sleeves and covers must be able to support the bearing rings adequately, without any contact between rotating parts of the bearing and a stationary component.

The transition between the bearing seat and shaft or housing shoulder, may either take the form of a simple fillet, or be relieved in the form of an undercut. Suitable dimensions for the fillets are provided in **Appendix D-3**, on **page 387**. The greater the fillet radius (for the smooth form curve), the more favourable is the stress distribution in the shaft fillet area.

For heavily loaded shafts, therefore, a large radius is generally required. In such cases a spacing collar should be provided between the inner ring and shaft shoulder to provide a sufficiently large support surface for the bearing ring. The side of the collar facing the shaft shoulder should be relieved so that it does not contact the shaft fillet (→ **fig. 19**).

CARB toroidal roller bearings

CARB toroidal roller bearings can accommodate axial expansion of the shaft within the bearing. To be sure that these axial displacements of the shaft with respect to the housing can take place, it is necessary to provide adequate space on both sides of the bearing (→ **fig. 20**).

To calculate the required abutment width, visit www.skf.com/bearings.

Fig. 19

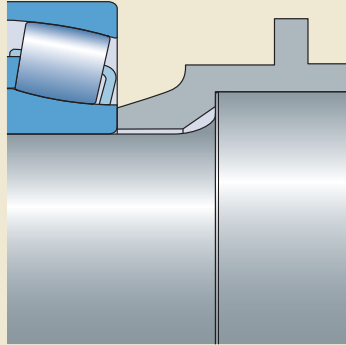
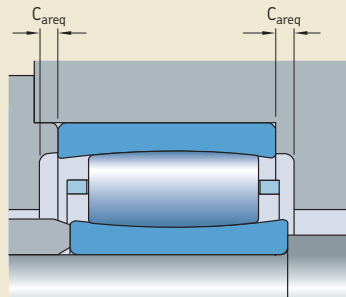


Fig. 20



Sealing arrangements

The performance of a sealing arrangement is vital to the cleanliness of the lubricant and the service life of the bearings. Where seals for rolling bearings are concerned, a distinction is made between seals that are integral to the bearing and those that are positioned outside the bearing.

External seals

There are two broad categories of external seals:

- contact seals
- non-contact seals

Seals in contact with stationary surfaces are known as static seals and their effectiveness depends on the radial or axial deformation of their cross section when installed. Typical examples include gaskets and O-rings. Seals in contact with sliding surfaces are called dynamic seals and are used to seal passages between a stationary component, e.g. a housing, and a rotating component, normally the shaft. Their function is to keep lubricant in and contaminants out of the bearing arrangement (→ fig. 21).

The most common contact seal is the radial shaft seal. Other types include V-ring seals and felt seals.

NOTE: When the primary function of a radial shaft seal is to retain the lubricant, it should be installed with the seal lip facing the lubricant, i.e. facing inward. When the primary function is to exclude contaminants, the seal lip should be facing the contaminants, i.e. facing outward.

Non-contact radial shaft seals function by virtue of the sealing effect of a narrow, relatively long gap that can be arranged axially, radially or in combination. Non-contact seals, which range from simple gap-type seals to multi-stage labyrinth seals (→ fig. 22), do not generate friction and do not wear.

NOTE: Non-contact seals are suitable for high-speed and/or high temperature applications.

Fig. 21

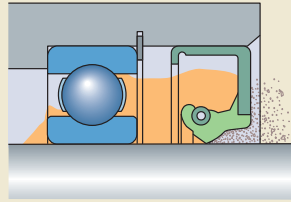


Fig. 22

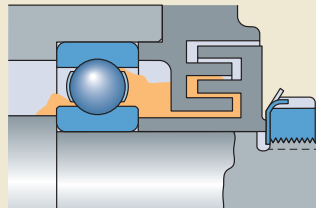
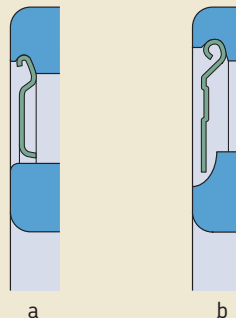


Fig. 23



Integral bearing sealing solutions

There are two categories of integral bearing sealing solutions:

- shields
- seals

Shields

Shields, produced from sheet steel, are non-contacting and are used in applications where contamination is limited. They are also used in applications where, due to speed or operating temperatures, low friction is important. The bearings are lubricated for life and should not be relubricated.

Shields form (→ **fig. 23, page 39**):

- a narrow gap with the inner ring shoulder (a)
- an efficient labyrinth seal with a recess in the inner ring shoulder (b)

Seals

Seals integrated in SKF bearings are generally made of elastomer materials and reinforced by sheet steel.

Bearings with contact seals are preferred for arrangements where resistance to contamination is needed, where the presence of moisture or water spray cannot be ruled out, or where a long service life with minimal maintenance is required.

How a seal contacts a bearing ring depends on the bearing type and design of the seal. Seals can make contact in any one of the following ways (→ **fig. 24**):

- with the inner ring shoulder (a) or against a recess in the inner ring shoulder (b, c, d)
- with the lead-in at the sides of the inner ring raceway (e, f) or the outer ring (g)

For deep groove ball bearings, SKF has also developed non-contact integral seals, which form an extremely small gap with the inner ring (→ **fig. 25a** and **b**) and low-friction integral seals, which practically do not contact the inner ring (→ **fig. 25c**). Both fulfil high demands on sealing and low-friction operation of the bearing. As a result, bearings fitted with these seals can be operated at the same speeds as bearings with shields, but with improved seal performance. They are lubricated for life and should not be relubricated.

Fig. 24

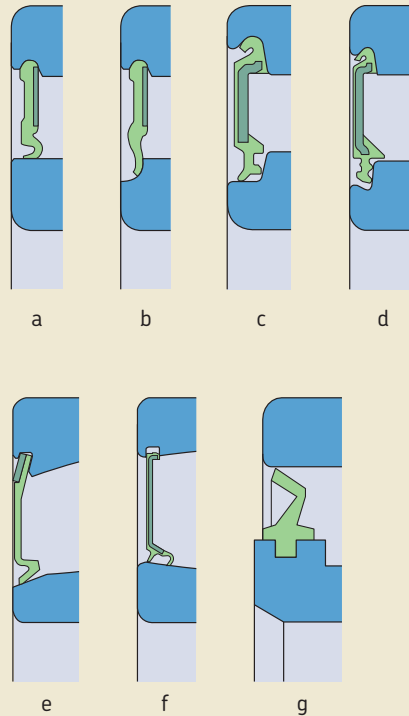
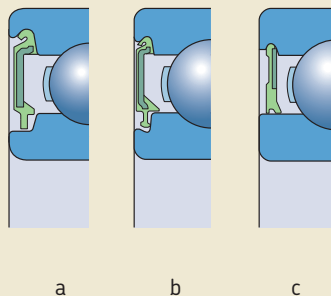


Fig. 25



Storage of bearings, seals and lubricants

The conditions under which bearings, seals and lubricants are stored can have an adverse effect on their performance. Inventory control can also play an important role in performance, particularly if seals and lubricants are involved. Therefore, SKF recommends a “first in, first out” inventory policy.

Storage of bearings, bearing units and housings

Storage conditions

To maximize the service life of bearings, SKF recommends the following basic housekeeping practices:

- Store bearings flat, in a vibration-free, dry area with a cool, steady temperature. There should not be a draft in the stocking area.
- Control and limit the relative humidity of the storage area as follows:
 - 75% at 20 °C (68 °F)
 - 60% at 22 °C (72 °F)
 - 50% at 25 °C (77 °F)
- Keep bearings in their original unopened packages until immediately prior to mounting, to prevent dust and moisture contamination as well as corrosion of the bearing components.

NOTE: Machines on standby should be rotated or run as frequently as possible to redistribute the grease within the bearings and change the position of the rolling elements relative to the raceways.

Bearing units and housings should be stored under similar conditions as bearings, i.e. in a

cool, dust-free, moderately ventilated room, where the relative humidity is controlled.

Shelf life of open bearings

SKF bearings are coated with a rust-inhibiting compound and suitably packaged before distribution. For open bearings, the preservative provides protection against corrosion for approximately five years, provided the storage conditions are appropriate. After five years, SKF recommends following these guidelines:

- 1 Remove the bearing from the package, without damaging the package if possible.
- 2 Clean the bearing using a suitable solvent.
- 3 Carefully dry the bearing.
- 4 Visually inspect the bearing for signs of corrosion or damage. If the bearing is in a satisfactory condition, apply a fresh coating of an appropriate rust-inhibiting compound and repack the bearing in its original package.

NOTE: Bearing inspection and repackaging is a service that can be provided by SKF. Contact your local SKF sales representative or SKF Authorized Distributor.

Shelf life of sealed bearings

The maximum storage interval for SKF sealed bearings is dictated by the lubricant inside the bearings. Lubricant deteriorates over time as a result of ageing, condensation, and separation of the oil and thickener. Therefore, sealed bearings should not be stored for more than three years.

NOTE: For small bearings, it is impractical to remove the seals, clean the bearing, re-grease it and then re-fit the seals. But more importantly, by doing this, the seals could be damaged and contaminants could be introduced into the bearings in the process.

Basics

Some larger bearings have seals retained in the outer ring by a circlip. Where necessary, the seals can be removed and replaced.

Storage of elastomer seals

Storage conditions

To maximize the service life of elastomer seals, SKF recommends the following basic house-keeping practices:

- Store elastomer seals flat, in a cool, moderately ventilated area, at temperatures between 15 and 25 °C (60 and 75 °F).
- Control and limit the relative humidity of the storage area to 65% maximum.
- Protect seals from direct sunlight or light with a high proportion of UV radiation.
- Keep seals in their original packages until just before mounting to prevent degradation of the material when subjected to the environment. If the original packages are not available, store them in airtight containers.
- Store seals separately from solvents, fuels, lubricants and other chemicals that produce fumes and vapours.
- Store seals made of different materials separately.

CAUTION: Seals should never be hung from pegs or nails during storage. If stored like this, under stress or load, seals are subject to permanent deformations and cracks.

Shelf life

Natural and synthetic rubber changes its physical properties over time and is affected by air, heat, light, moisture, solvents and certain metals, especially copper and manganese. As a result, rubber seals may become unusable due to hardening or softening, peeling, cracks or other surface damage.

Storage of lubricants

Storage conditions

Lubricants are affected by temperature, light, water, moisture and oxygen. Incidental exposure to these elements is normally not harmful. However, any exposure hastens the onset of ageing.

To maximize lubricant shelf life, SKF recommends the following:

- Store lubricants in a vibration-free, dry area where the temperature is below 40 °C (105 °F). This is particularly important for containers that have been opened, as humidity causes lubricant degradation and accelerates oxidation.
- Store lubricants indoors on proper storage racks. Indoor storage also protects any labelling on the container.
- Store oil drums on their sides to keep contaminants from collecting on the top of the drums.
- Keep container lids closed to prevent the entry of contaminants.
- Label all containers clearly. Identification problems may arise if labels are worn or damaged. Colour coding is also recommended.
- Keep lubricants in their original containers.
- Do not store dispensed lubricant in open cans.

Shelf life

The shelf life of a lubricant is the period from the fill date to an estimated expiration date, provided the lubricant is stored properly. Production dates are normally coded on the containers and should be monitored regularly. In general, the production date on SKF bearing grease cans and automatic lubricators, for example, is indicated by a four-digit code such as 0710, which indicates the grease was produced in 2007, week 10.

Most lubricants will deteriorate over time. Guidelines for the shelf life of various lubricants are provided in **table 3**.

If a lubricant has exceeded its shelf life, it may not be as effective. Therefore, SKF strongly recommends using only those lubricants that are well within their estimated expiration date.

NOTE: Consider the cost implications of a machine breakdown as a result of expired lubricant, compared to the cost of replacing the lubricant.

Lubricant disposal

Improper disposal of lubricants can be hazardous to the community and the environment. Dispose of all lubricants in accordance with national and local laws and regulations and good environmental safety practices.

Table 3

Lubricant shelf life at 20 °C (70 °F)

Lubricant	Maximum shelf life
Lubricating oils	10 years ¹⁾
SKF aftermarket greases (except the food grade grease LGFP 2)	5 years
SKF food grade grease LGFP 2	2 years
Grease in sealed SKF deep groove ball bearings, e.g. MT47, MT33 or GJN	3 years
Lubricant in SKF SYSTEM 24 lubricators in the LAGD series	2 years
Lubricant in SKF SYSTEM 24 lubricators in the LAGE series (except when filled with LGFP 2 or oil)	3 years
Lubricant in SKF SYSTEM 24 lubricators in the LAGE series filled with LGFP 2 or oil	2 years

¹⁾ Shelf lives may be reduced due to certain additive packages in the lubricant. Check with the lubricant manufacturer.



Mounting rolling bearings

Preparations prior to mounting	46	SKF mounting tools	72
Planning	46	Mechanical tools	72
Cleanliness	46	Hydraulic tools	73
Removing the preservative from new bearings	47	Heating equipment	73
Checking associated components	47	Gloves	73
Safety	49	Mounting instructions by bearing type . .	74
Preparing components	49	Mounting angular contact ball bearings	74
Bearing handling	49	Stand-alone bearings	74
Bearing internal clearance	51	Adjusting face-to-face bearing arrangements	74
Clearance before and after mounting	51	Adjusting back-to-back bearing arrangements	76
Measuring clearance with a feeler gauge	52	Universally matchable bearings and matched bearing sets	76
Cold mounting	53	Angular contact ball bearings with a two-piece inner ring	78
Mechanical methods	53	Mounting self-aligning ball bearings	79
Bearings with a cylindrical bore	53	Basic design bearings with protruding balls	79
Bearings with a tapered bore	54	Sealed bearings with a tapered bore	79
SKF Drive-up Method	57	Bearings with an extended inner ring . . .	80
SKF Drive-up Method: Step-by-step	58	Mounting cylindrical and needle roller bearings	80
Oil injection method	62	Single row cylindrical and needle roller bearings with a cage	80
Oil injection method: Step-by-step	62	Four-row cylindrical roller bearings	82
SensorMount	67	Mounting tapered roller bearings	84
Hot mounting	68	Single row tapered roller bearings	84
Electric hot plates	68	Double row and multi-row tapered roller bearings	89
Induction heaters	69	Mounting spherical roller and CARB toroidal roller bearings	90
Aluminium heating rings	69	Sealed spherical roller bearings	90
Heating cabinets	70	CARB toroidal roller bearings	91
Infrared radiators	70		
Heating panels	71		
Oil baths	71		

Preparations prior to mounting

Rolling bearings are reliable machine elements that can provide long service life, provided they are properly mounted and maintained. Proper mounting calls for experience as well as care, cleanliness, accuracy, the correct mounting method and the use of appropriate tools for the job.

Planning

Prior to mounting, study any drawings or instructions to determine:

- the correct order in which to assemble the various components
- the correct bearing type, size and variant
- the appropriate lubricant and quantity to be used
- the appropriate mounting method
- the appropriate mounting tools

The tools and methods used to mount rolling bearings often depend on the size of the bearing. Generally, bearings can be categorized as:

- small bearings: bore diameter $d \leq 80$ mm
- medium-size bearings: bore diameter $80 \text{ mm} < d < 200$ mm
- large bearings: bore diameter $d \geq 200$ mm

For additional information about SKF mounting tools, including mechanical tools, hydraulic tools, heating equipment and gloves, visit www.mapro.skf.com.

For detailed mounting instructions for specific bearings (per bearing designation), visit www.skf.com/mount.

The SKF Reliability Maintenance Institute (RMI) offers a comprehensive range of training courses in mounting (→ *Training*, starting on **page 326**). Contact your local SKF representative for additional information, or visit www.skf.com/services.

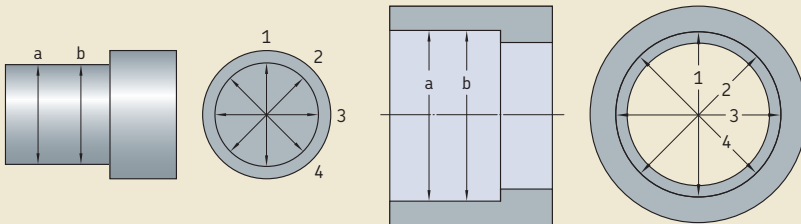
Cleanliness

Cleanliness is essential to long bearing service life. Cleanliness begins in the storage room. Store bearings in a cool, dry area, on shelves that are not subjected to vibrations from adjacent machinery (→ *Storage of bearings, seals and lubricants*, starting on **page 41**). Do not open the bearing package until it is time to install the bearing.

Whenever possible, install bearings in a dry, dust-free area, away from metalworking or other machines producing swarf and dust. Make sure that the bearings and all mating parts, including the lubricant, are clean and free from damaging contaminants.

When bearings have to be mounted in an unprotected area, which is often the case with

Fig. 1



large bearings, steps need to be taken to protect the bearing and mounting position from contaminants such as dust, dirt and moisture, until installation has been completed. This can be done by covering or wrapping bearings, machine components etc. with plastic or foil.

NOTE: It is better to prevent bearings from becoming dirty than to clean them. Many bearing types cannot be separated and are therefore difficult to clean.

Removing the preservative from new bearings

Bearings should be left in their original packages until immediately before mounting so that they will not be exposed to any contaminants, especially dirt. Normally, the preservative applied to new bearings does not need to be completely removed. It is only necessary to wipe off the outside diameter and bore surfaces.

CAUTION: SKF recommends carefully washing and drying the bearings if the bearings are to be grease lubricated and used at very high or very low temperatures. The bearings should also be washed if the lubricant to be used is not compatible with the preservative (→ *Compatibility between greases and SKF bearing preservatives*, page 202).

Checking associated components

A bearing will only perform satisfactorily if the associated components have the requisite accuracy and if the prescribed tolerances are adhered to. Therefore:

- Remove any burrs or rust.
- Check the dimensional and form accuracy of all associated components of the bearing arrangement.
- Check cylindrical shaft seats. Using a micrometer, measure in two places on the shaft seat. Be sure to measure in four directions (→ **fig. 1**). For large seats, measuring in three or four places might be needed (→ **Measurement report form**, page 48).
- Check tapered shaft seats using a ring gauge (→ **fig. 2**), a taper gauge (→ **fig. 3**) or a sine bar (→ **fig. 4**).

Fig. 2

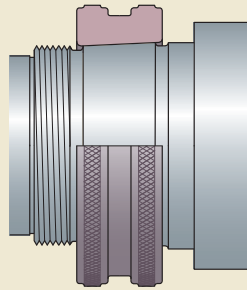


Fig. 3

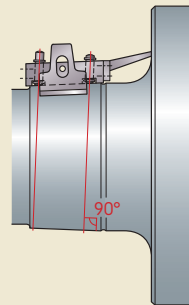
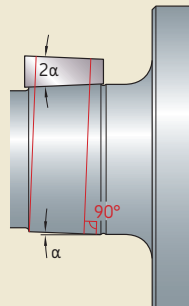


Fig. 4



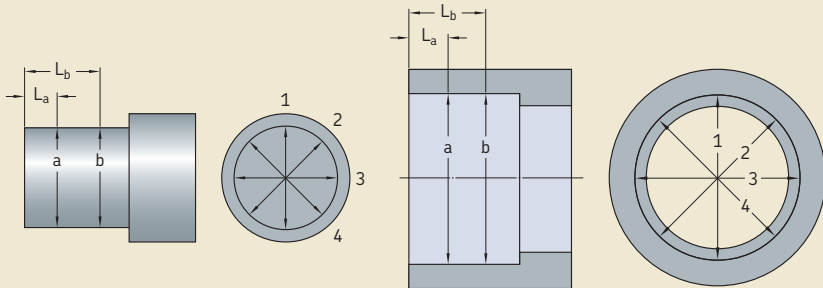
Mounting rolling bearings

Measurement report form

Bearing:

Bearing position:

Application:



Measuring directions	Shaft Measurement values [mm] at place				Housing Measurement values [mm] at place			
	a	b	(c)	(d)	a	b	(c)	(d)
	Distance L				Distance L			
	Diameter d				Diameter D			
1								
2								
3								
4								
	Calculated mean: $(1+2+3+4)/4$				Calculated mean: $(1+2+3+4)/4$			

Remarks:

Date:

Checked by:

- Housing seats are usually checked in two places with an internal micrometer or other comparable measuring gauge. Be sure to measure in four directions (→ **fig. 1, page 46**). For large seats, measuring in three or four places might be needed.
- Record the measurement values of the shaft and bore diameters for future reference. Use the measurement report form.

When measuring, it is important that the components and the measuring instruments are at the same approximate temperature. This is particularly important where large bearings and their associated components are concerned.

Safety

To minimize the chance of injury, when handling or mounting bearings:

- Always wear gloves, especially when handling heated bearings or working with lubricants.
- Always use appropriate lifting or carrying tools.
- Never strike the bearing directly with any hard object such as a steel hammer or a chisel.

Preparing components

Before mounting a bearing, prepare the associated components and do the following:

- Mount any components that are on the shaft in front of the bearing.
- For a tight shaft and/or housing fit, coat the bearing seat(s) with a thin layer of light oil.
- For a loose shaft and/or housing fit, coat the bearing seat(s) with SKF anti-fretting agent.
- If the shaft or sleeve is equipped for oil injection, make sure that the ducts and grooves are clean.

Bearing handling

SKF recommends using gloves as well as carrying and lifting tools that have been specially designed for mounting bearings. In addition to being a safety issue, using the proper tools will save time and effort.

When handling hot or oily bearings, SKF recommends wearing the appropriate heat or oil resistant gloves (→ *Gloves*, **page 73**).

Heated bearings and larger, heavier bearings can be difficult for one or two persons to handle safely. In these instances, satisfactory equipment for lifting and transporting the bearing should be used (→ **figs. 5, 6 and 7, page 50**).

2

Fig. 5

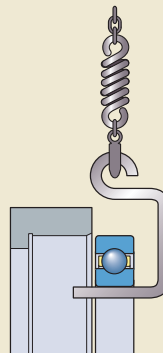
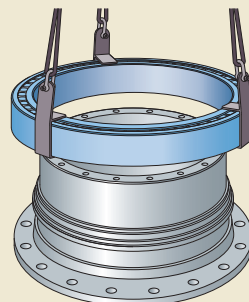


Fig. 6



Mounting rolling bearings

For large, heavy bearings, use lifting tackle that supports the bearing from the bottom (→ **fig. 8**). Never suspend the bearing from a single point, as it could permanently deform the rings. A spring between the hook and tackle (→ **fig. 5, page 49**) can facilitate positioning the bearing onto the shaft.

Large bearings provided with threaded holes in one of the ring side faces can accommodate eye bolts. Because the size and depth of the hole is limited by the ring thickness, these holes are designed to accommodate only the weight of the bearing.

Make sure that the eye bolts are only subjected to load in the direction of the shank axis (→ **fig. 9**).

CAUTION: Never place any additional components on the bearing prior to lifting.

When mounting a solid, large housing over a bearing that is already in position on a shaft, it is advisable to provide three-point suspension for the housing, with one of the slings adjustable. This facilitates the process of aligning the housing bore with the bearing outside diameter.

Fig. 7

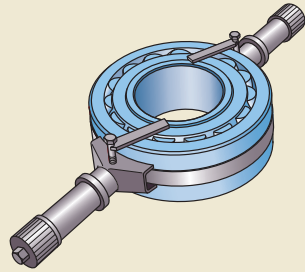


Fig. 8

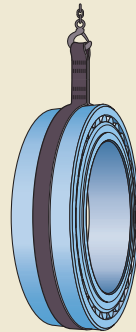
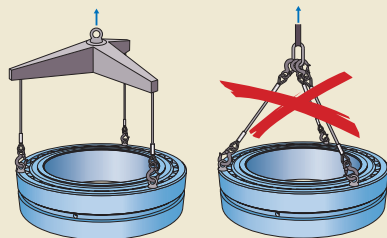


Fig. 9



Bearing internal clearance

The internal clearance of a bearing is the total distance through which one bearing ring can be moved relative to the other.

Movement in the radial direction is called “radial internal clearance”; axial movement is called “axial internal clearance” (→ **fig. 10**).

Clearance before and after mounting

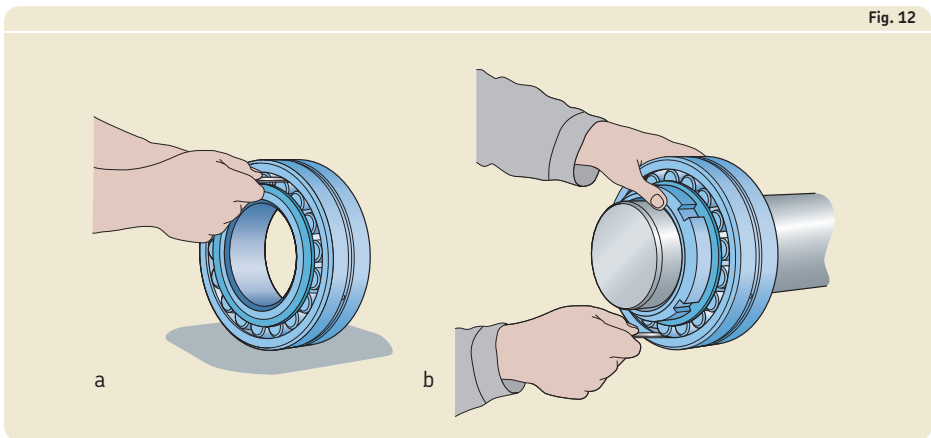
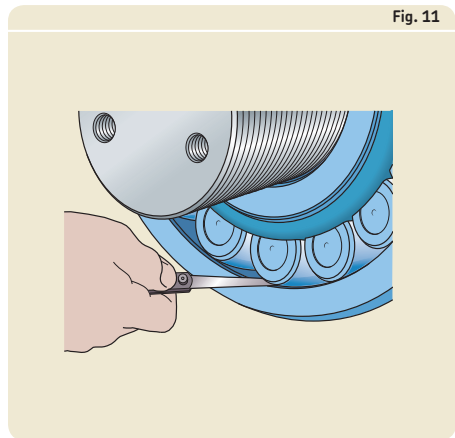
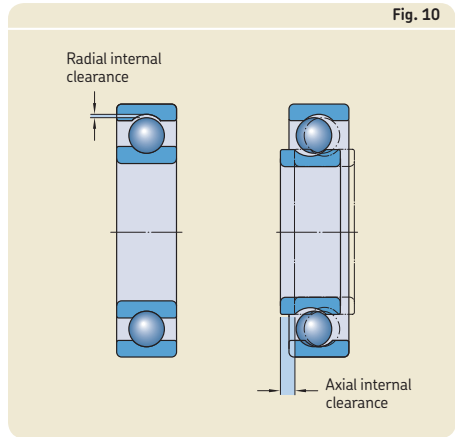
It is important to distinguish between the internal clearance of a bearing before mounting and the internal clearance of a mounted bearing under actual operating conditions.

Clearance before mounting is usually greater than the operational clearance because the rings expand or compress due to the interference fit, and because of thermal expansion of the bearing rings and associated components.

As a general rule, operational radial internal clearance should be slightly greater than zero, while a slight preload for ball bearings usually has no detrimental effect. Preload is usually not recommended for replacement bearings because the seats might not be optimal anymore.

Values for clearance before mounting can be found in **Appendix E**, starting on **page 388**.

2



Mounting rolling bearings

Measuring clearance with a feeler gauge

A feeler gauge is most often used to measure the radial internal clearance in medium-size and large spherical roller bearings and CARB toroidal roller bearings, before, during and after mounting (→ **fig. 11, page 51**).

Before measuring, rotate the inner or outer ring a few times. Make sure that both bearing rings and the roller complement are centrally arranged relative to each other.

To start, select a feeler gauge blade that is slightly thinner than the minimum value for initial bearing clearance (→ **Appendix E, starting on page 388**). When measuring, move the blade back and forth between the middle of the roller and raceway. Repeat this procedure using a thicker blade each time until you can feel a slight resistance between the blade and roller. To confirm the value, rotate the inner ring 180 degrees and measure again. Take measurements between:

- the outer ring and uppermost roller, before mounting (→ **fig. 12a, page 51**)
- the outer ring and lowest roller, after mounting (→ **fig. 12b, page 51**)

For large bearings, especially those having a rather thin-walled outer ring, the measurements are affected by the elastic deformation of the rings, caused by the weight of the bearing or the force to draw the feeler gauge blade through the gap between the raceway and an unloaded roller. To establish the "true" clearance before

and after mounting, use the following procedure (→ **fig. 13**):

- Measure the clearance "c" at the 12 o'clock position for a standing bearing or at the 6 o'clock position for an unmounted bearing hanging from the shaft.
- Measure the clearances "a" at the 9 o'clock position and "b" at the 3 o'clock position without moving the bearing.
- Obtain the "true" radial internal clearance with relatively good accuracy from $0,5(a + b + c)$.

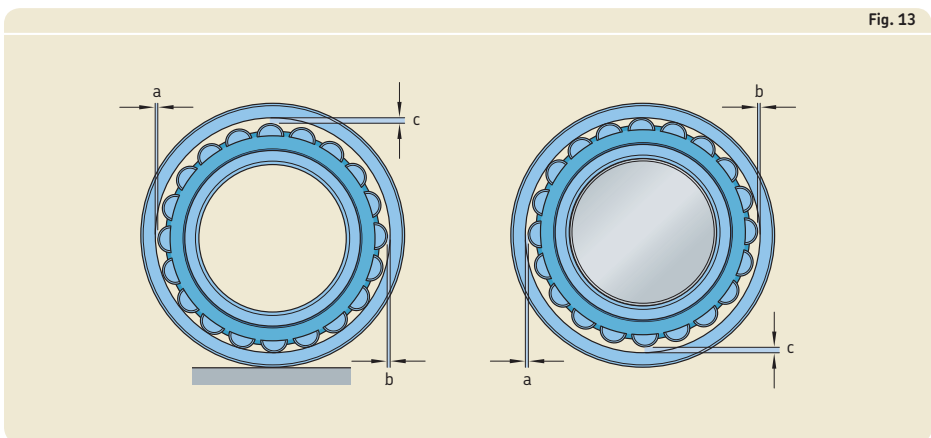


Fig. 13

Cold mounting

For cold mounting, there is a choice of methods:

- mechanical methods
- the SKF Drive-up Method
- the oil injection method
- measuring inner ring expansion (SensorMount)

Mechanical methods are usually used to drive small bearings with a cylindrical or tapered bore onto a shaft or into a housing. The other three methods are only used to drive up bearings with a tapered bore onto a tapered seat.

CAUTION: When mounting a bearing, never strike it directly with any hard object such as a steel hammer or a chisel, and never apply the mounting force through the rolling elements.

Mechanical methods

Bearings with a cylindrical bore

Small bearings should be mounted with an appropriate bearing fitting tool, e.g. the SKF Bearing fitting tool kit (→ **fig. 14a**).

If the shaft has an external (→ **fig. 14b and c**) or an internal thread (→ **fig. 14d**), the threads can be used to mount the bearing onto a shaft.

If a bearing has to be pressed onto the shaft and into the housing bore at the same time, the mounting force must be applied equally to both rings (→ **fig. 15**).

To mount a larger number of bearings, a mechanical or hydraulic press can be used. When using a press, place an appropriate sleeve between the ram and the ring to be mounted (→ **fig. 16, page 54**).

Fig. 14

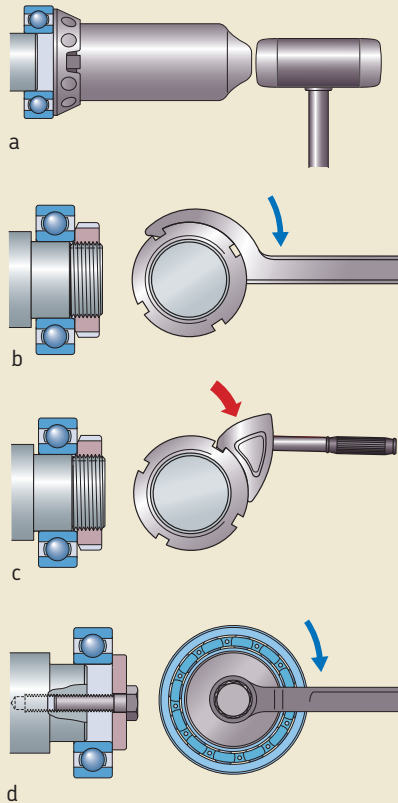
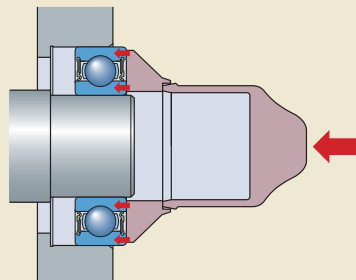


Fig. 15



Mounting rolling bearings

Bearings with a tapered bore

Small and medium-size bearings can be driven up onto a tapered seat using either a bearing fitting tool or preferably a lock nut. In the case of adapter sleeves, the sleeve nut is used.

A hook or impact spanner can be used to tighten the nut (→ **fig. 17**) and to drive up the bearing on its tapered seat. Small withdrawal sleeves may be driven into the bearing bore using a bearing fitting tool or an end plate.

Bearings with a bore diameter $d \geq 50$ mm can be simply and reliably mounted, applying the SKF Drive-up Method (→ *SKF Drive-up Method*, starting on **page 57**).

Combining the SKF Drive-up Method and the oil injection method facilitates mounting medium-size and large bearings (→ *Oil injection method*, starting on **page 62**).

Combining the oil injection method and SensorMount further simplifies the mounting of large bearings (→ *SensorMount*, **page 67**).

Bearings with a tapered bore are mounted with an interference fit. The degree of interference is normally determined by one of the following methods:

- feeling the clearance reduction by swivelling the outer ring
- measuring the clearance reduction with a feeler gauge
- measuring the lock nut tightening angle
- measuring the axial drive-up
- measuring the inner ring expansion

NOTE: Applying the recommended values for the clearance reduction, the lock nut tightening angle, the axial drive-up or the inner ring expansion prevents the inner ring from creeping under normal operating conditions, but does not ensure correct radial internal clearance in operation. Additional influences from the bearing housing fit and temperature differences between the inner ring and outer ring, must be considered carefully when selecting the bearing radial internal clearance class. For additional information, contact the SKF application engineering service.

Fig. 16

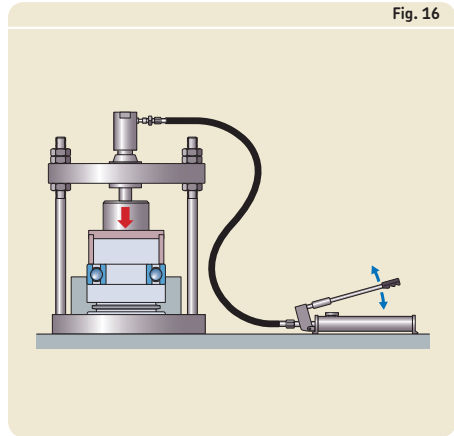


Fig. 17

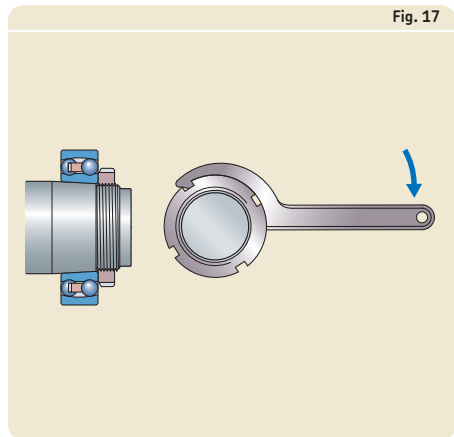
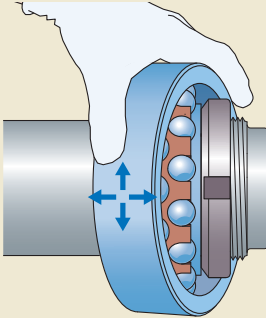


Fig. 18



Feeling the clearance reduction by swivelling the outer ring

When mounting self-aligning ball bearings with Normal radial clearance, it is generally sufficient to check clearance reduction during axial drive-up by turning and swivelling the outer ring (→ **fig. 18**). The clearance reduction in the bearing is sufficient when the outer ring can be easily turned, but a slight resistance is felt when it is swivelled out.

Measuring the clearance reduction with a feeler gauge

Using a feeler gauge (→ **fig. 12, page 51**) is one way to measure the radial internal clearance in medium-size and large bearings, before, during, and after mounting (→ *Measuring clearance with a feeler gauge, page 52*).

Recommended values for reduction of radial internal clearance are provided for:

- spherical roller bearings in **Appendix F-2** (→ **page 403**)
- CARB toroidal roller bearings in **Appendix F-3** (→ **page 404**)

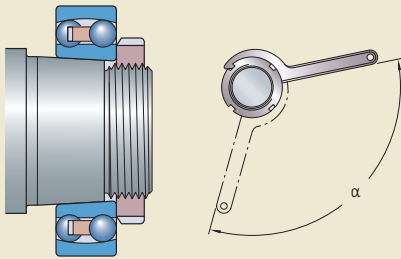
Measuring the lock nut tightening angle (α)

SKF recommends this method (→ **fig. 19**) for mounting small to medium-size bearings with a tapered bore and up to approximately 120 mm bore diameter. Guideline values for the lock nut tightening angle (α) are provided for:

- self-aligning ball bearings in **Appendix F-1** (→ **page 402**)
- spherical roller bearings in **Appendix F-2** (→ **page 403**)
- CARB toroidal roller bearings in **Appendix F-3** (→ **page 404**)

Before starting the final tightening procedure, place the bearing onto the tapered seat until it is firmly in position. By tightening the nut through the recommended angle (α), the bearing is driven up over the proper distance on the tapered seat. The bearing inner ring then has the requisite interference fit.

Fig. 19



Mounting rolling bearings

Measuring the axial drive-up

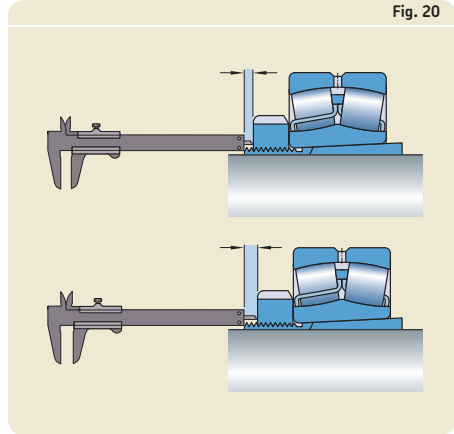
Controlling the axial displacement of a bearing on its tapered seat provides an easy way to achieve the fit. One way is to simply measure the axial displacement (→ **fig. 20**). This method is not very accurate since it is not easy to determine the start position.

Guideline values for axial drive-up are provided for:

- self-aligning ball bearings in **Appendix F-1** (→ **page 402**)
- spherical roller bearings in **Appendix F-2** (→ **page 403**)
- CARB toroidal roller bearings in **Appendix F-3** (→ **page 404**)

The most suitable method is the SKF Drive-up Method, which is an easy, fast and very reliable method to achieve the correct drive-up and thereby the appropriate interference fit (→ *SKF Drive-up Method*, starting on **page 57**).

Fig. 20



Measuring the inner ring expansion

Measuring the inner ring expansion when the bearing is driven up on its tapered seat simplifies the mounting process of large bearings. To do this, SensorMount, available with a sensor imbedded in the bearing inner ring and a dedicated hand-held indicator (→ *SensorMount*, **page 67**).

Table 1

Suitable tools for the SKF Drive-up Method

Designation	Description
Hydraulic nuts HMV ..E, e.g. HMV 40E HMVC ..E, e.g. HMVC 40E	Hydraulic nut with a metric thread, e.g. M 200 × 3 Hydraulic nut with an inch thread, e.g. ANF 7.847 × 8 Class 3
Pumps 729124 SRB	Hand operated hydraulic pump for – working pressure up to 100 MPa and – hydraulic nuts up to 270 mm thread diameter
TMJL 100 SRB	Hand operated hydraulic pump for – pressure up to 100 MPa and – hydraulic nuts up to 460 mm thread diameter
TMJL 50 SRB	Hand operated hydraulic pump for – working pressure up to 50 MPa and – hydraulic nuts up to 1 000 mm thread diameter
Pressure gauge TMJG 100 D	Pressure range: 0 – 100 MPa
Dial indicators TMCD 10R TMCD 1/2R TMCD 5	Horizontal dial indicator for measuring displacement up to 10 mm Horizontal dial indicator for measuring displacement in inches, up to 0.5 in. Vertical dial indicator for measuring displacement up to 5 mm

Fig. 21

SKF Drive-up Method

The SKF Drive-up Method is recommended for medium-size and large bearings. The method is based on a two-stage mounting procedure using a hydraulic nut fitted with a dial indicator.

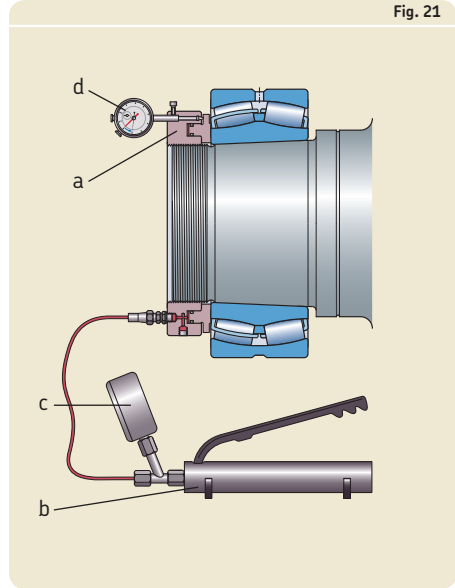
Stage one: by applying a predetermined pressure in the hydraulic nut, a reliable start position is reached.

Stage two: by increasing the pressure in the hydraulic nut, the bearing inner ring is pushed further on its tapered seat. The displacement is measured by the dial indicator, until a predetermined axial displacement is obtained. Guideline values for the requisite oil pressure to reach the start position and the axial displacement to reach the final position are provided for:

- self-aligning ball bearings in **Appendix H-1** (→ **page 406**)
- spherical roller bearings in **Appendix H-2** (→ **page 407**)
- CARB toroidal roller bearings in **Appendix H-3** (→ **page 411**)

The SKF Drive-up Method requires the following tools (→ **table 1** and **fig. 21**):

- an SKF HMV ..E or HMVC ..E hydraulic nut (**a**)
- a suitably sized hydraulic pump (**b**)
- a pressure gauge, appropriate to the mounting conditions (**c**)
- an appropriate dial indicator (**d**)



Mounting rolling bearings

SKF Drive-up Method: Step-by-step

- 1 Before starting, carefully follow the guidelines provided under *Preparations prior to mounting*, starting on **page 46**, and apply where appropriate.
- 2 Determine whether one or two surfaces slide during mounting (→ **fig. 22**):
 - one surface: **cases 1, 2 and 3**
 - two surfaces: **cases 4 and 5**
- 3 Check whether the bore diameter of the bearing and the thread diameter of the hydraulic nut are equal (→ **fig. 22: cases 1, 3 and 4**). If so, the requisite oil pressure to reach the start position is provided for:
 - self-aligning ball bearings in **Appendix H-1** (→ **page 406**)
 - spherical roller bearings in **Appendix H-2** (→ **page 407**)
 - CARB toroidal roller bearings in **Appendix H-3** (→ **page 411**)
- 4 Coat the sliding surfaces with a thin layer of light oil and place the bearing on the tapered shaft or sleeve.
- 5 Screw the hydraulic nut onto the thread of the shaft or sleeve so that it abuts the bearing or the withdrawal sleeve (→ **fig. 23**).

NOTE: Detailed mounting instructions, specific to the bearing designation can be found at www.skf.com/mount.

If the bore diameter of the bearing and the thread diameter of the hydraulic nut are not equal (→ **fig. 22: cases 2 and 5**), the requisite oil pressure to reach the start position must be adjusted, as a smaller hydraulic nut is used than that shown for the appropriate bearing. In these cases, the requisite oil pressure can be calculated from

$$P_{\text{req}} = \frac{A_{\text{ref}}}{A_{\text{req}}} P_{\text{ref}}$$

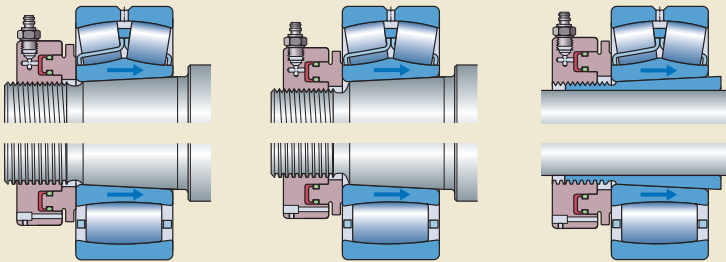
where

- P_{req} = requisite oil pressure for the actual hydraulic nut [MPa]
- P_{ref} = oil pressure specified for the reference hydraulic nut [MPa]
- A_{req} = piston area of the actual hydraulic nut [mm²]
- A_{ref} = piston area of the specified reference hydraulic nut [mm²]

The appropriate values for P_{ref} , A_{req} and A_{ref} are listed in the above-mentioned appendices.

Fig. 22

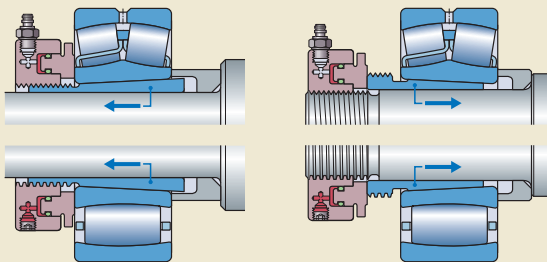
Steps 2 and 3: Determine the number of sliding surfaces and appropriate starting pressure.



case 1

case 2

case 3

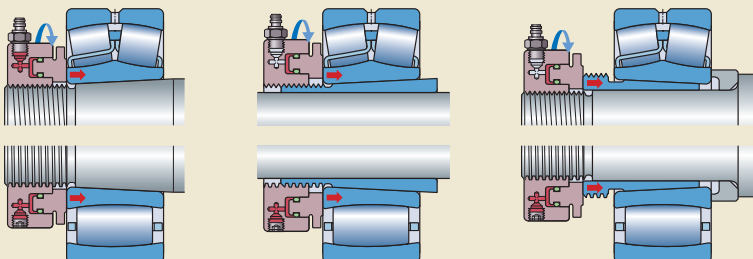


case 4

case 5

Fig. 23

Step 5: Put the hydraulic nut in place.



Tapered shaft

Adapter sleeve

Withdrawal sleeve

Mounting rolling bearings

Fig. 24

Step 6: Apply the requisite pressure to reach the start position.

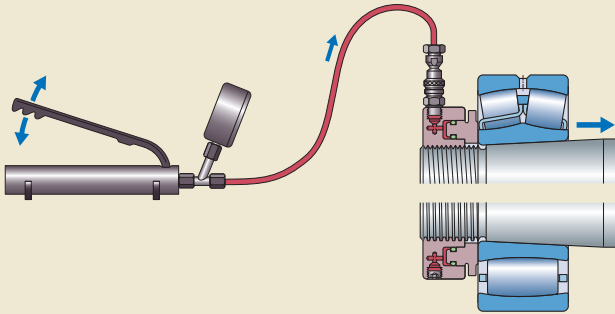


Fig. 25

Step 7: Read the axial displacement from the dial indicator.

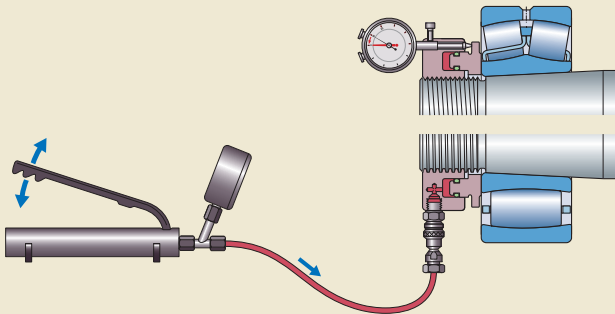
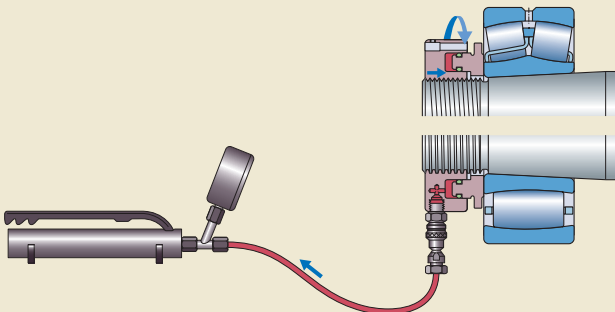


Fig. 26

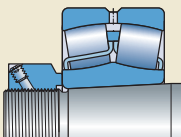
Step 9: Drain the oil from the hydraulic nut.



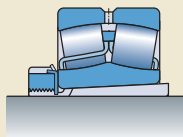
- 6 Connect the oil pump with the hydraulic nut. Drive the bearing to its start position by applying oil to the hydraulic nut until the requisite pressure is reached. Do not release the pressure (→ **fig. 24**).
- NOTE:** When mounting the bearing in combination with the oil injection method, do not inject oil between the contact surfaces before having reached the start position.
- 7 Attach the dial indicator to the hydraulic nut. Set the dial indicator to the required drive-up distance. Pump additional oil to the hydraulic nut until the bearing has been driven up the required distance and the dial indicator reads zero (→ **fig. 25**).
- NOTE:** If the oil injection method is used, open the oil release valve of the oil pump(s) used for the oil injection (to the shaft or sleeve) and allow the oil to drain for at least 20 minutes.
- 8 When mounting is complete, open the oil release valve of the oil pump to depressurize the oil.
- 9 To drain the oil, bring the piston of the hydraulic nut to its original position. To do this, screw the nut up the threaded portion of the shaft or sleeve (→ **fig. 26**).
- 10 Disconnect the oil pump and remove the nut from the shaft or sleeve. The bearing will not come loose.
- 11 Secure the bearing on its shaft seat or on the sleeve, e.g. using the appropriate locking device (→ **fig. 27**).

Fig. 27

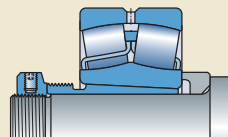
Step 11: Secure the bearing on its shaft seat or on the sleeve.



Tapered shaft



Adapter sleeve



Withdrawal sleeve

Mounting rolling bearings

Oil injection method

Using the oil injection method (→ **fig. 28**) can save considerable effort when mounting a bearing with a tapered bore. With this method, oil under high pressure is injected between the bearing bore and its seat to form an oil film. This oil film separates the mating surfaces and appreciably reduces the friction between them.

Provided the application has been prepared for oil injection (→ **Appendix G, page 405**), this method can be used to mount a bearing:

- on a tapered shaft
- on an adapter sleeve
- on a withdrawal sleeve

The equipment required for the oil injection method is also available from SKF. Products are shown and described under *Hydraulic tools*, on **page 73**.

If the oil injection method is applied when mounting medium-size and large bearings, SKF recommends the following step-by-step mounting procedure.

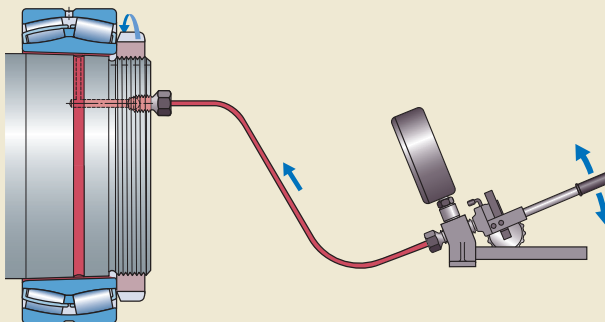
Oil injection method: Step-by-step

- 1 Before starting, carefully follow the guidelines provided under *Preparations prior to mounting*, starting on **page 46**, and apply where appropriate.
- 2 Measure the bearing radial internal clearance. Also, determine the required clearance reduction and the axial drive-up distance (→ *SKF Drive-up Method*, starting on **page 57**) of the bearing. Guideline values are provided for:

- self-aligning ball bearings in **Appendix F-1** (→ **page 402**)
- spherical roller bearings in **Appendix F-2** (→ **page 403**)
- CARB toroidal roller bearings in **Appendix F-3** (→ **page 404**)

NOTE: When measuring the radial internal clearance, follow the instructions provided under *Measuring clearance with a feeler gauge* on **page 52**.

Fig. 28

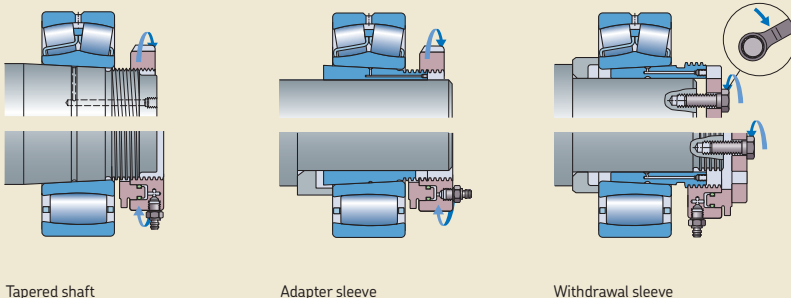


- 3 Sleeve mounting:
 - If applicable, remove the nut and locking device. When using a lock nut to drive the bearing into position, coat the sleeve thread and the side of the nut facing the bearing with a molybdenum disulphide paste.
- 4 Coat all the mating surfaces with a thin layer of light oil.
- 5 Start to mount the bearing (→ fig. 29).
 - Tapered shaft:
 - Push the bearing onto its seat.
 - Adapter sleeve:
 - Slide the sleeve into position. Place the bearing onto the sleeve.
 - Withdrawal sleeve:
 - Place the bearing centrally on the shaft and against the abutment. Push the sleeve along the shaft into the bearing bore.
- 6 Put the accessories in place.
 - Tapered shaft:
 - Screw the lock nut or hydraulic nut onto the shaft until the bearing is firmly in position.
 - Adapter sleeve:
 - Screw the lock nut or hydraulic nut onto the sleeve until the bearing is firmly in position.
 - Withdrawal sleeve:
 - When using a hydraulic nut or applying the SKF Drive-up Method to drive the sleeve into the bearing bore, screw the nut onto the sleeve with the piston facing outward, leaving at least a gap corresponding to the axial mounting distance. Provide a stop on the shaft, e.g. an end plate for the piston to work against.

NOTE: For excessive sliding resistance, slightly expand the sleeve by inserting a small plastic wedge in the slot of the sleeve.

Fig. 29

Steps 5 and 6: Put the bearing and accessories in place.



Mounting rolling bearings

- 7 Install the appropriate fittings and pipes (→ fig. 30).
Tapered shaft:
 - Install the fitting into the threaded hole for the oil supply at the shaft end.Adapter sleeve:
 - Screw the oil supply extension pipe with a quick-connector into the threaded side of the sleeve.Withdrawal sleeve:
 - Screw the oil supply extension pipe with a quick-connector into the threaded side of the sleeve.
- 8 Connect the appropriate oil pump(s).

NOTE: When applying the SKF Drive-up Method, follow the procedure provided under *SKF Drive-up Method*, starting on page 57.

- 9 Inject oil with a viscosity of approximately $300 \text{ mm}^2/\text{s}$ at $20 \text{ }^\circ\text{C}$ ($70 \text{ }^\circ\text{F}$), e.g. SKF Mounting fluid, between the mating surface(s) until the contact surfaces are separated by a layer of oil (→ fig. 31).
- 10 Drive up the bearing (→ fig. 32).
Tapered shaft:
 - Drive up the bearing the determined distance to its final position on the shaft by tightening the lock nut or operating the hydraulic nut.

Adapter sleeve:

- Drive up the bearing the determined distance to its final position on the sleeve by tightening the lock nut or operating the hydraulic nut.

Withdrawal sleeve:

- Drive the sleeve into the bearing bore to the determined axial distance by tightening the screws in turn or operating the oil pump of the hydraulic nut.

NOTE: When using the SKF Drive-up Method, apply the appropriate oil pressure to the hydraulic nut until the bearing is in the start position. Then position the dial indicator and set it to the required drive-up value. Continue to pump oil until the indicator reaches the drive-up distance. The indicator will then read zero.

Fig. 30

Steps 7 and 8: Install fittings and pipes, and connect the oil injection equipment.

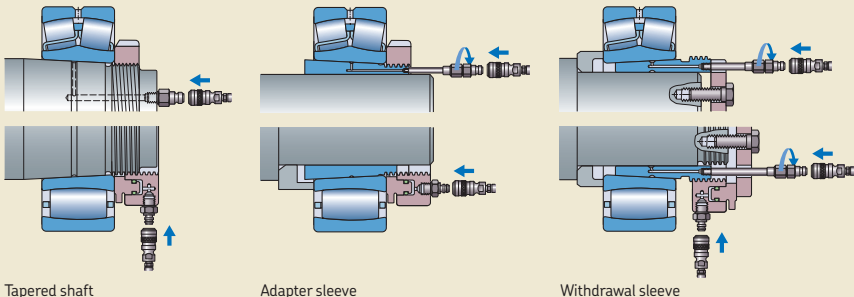
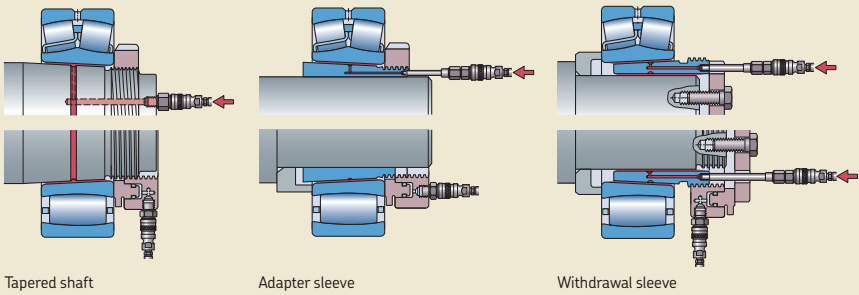


Fig. 31

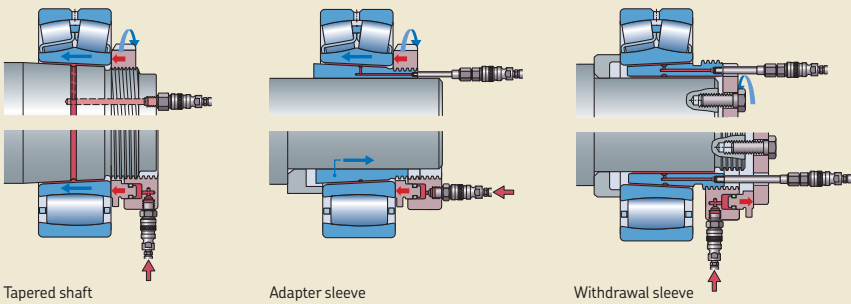
Step 9: Inject oil under high pressure to separate the mating surfaces.



2

Fig. 32

Step 10: Drive up the bearing.



Mounting rolling bearings

11 When mounting is complete, open the oil release valve to the pump(s) used for oil injection. Allow the oil to drain for at least 20 minutes.

CAUTION: When using the SKF Drive-up Method, do not release the pressure to the hydraulic nut at this stage.

12 Check the residual radial internal clearance using a feeler gauge.

NOTE: When using the SKF Drive-up Method, it is not necessary to check radial internal clearance after mounting.

13 If the residual clearance is in accordance with the recommended values, disconnect the oil supply to the shaft or sleeve (including the extension pipe), remove the fitting and replace the oil duct.

NOTE: When using the SKF Drive-up Method, open the oil release valve on the pump that operates the hydraulic nut. To empty the nut, return the piston to the start position by screwing the nut up the thread.

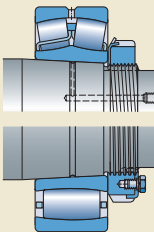
14 Where applicable, remove the lock nut, hydraulic nut or the screws on the end plate. The assembly will not come free.

15 Secure the bearing with the appropriate locking device (→ **fig. 33**):

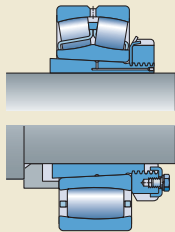
- For KM or KML lock nuts, use the appropriate MB or MBL lock washer.
- For HM 30 and HM 31 series lock nuts, use the supplied locking clip and bolt.
- For applications with an end plate, use bolts and appropriate spring washers.

Fig. 33

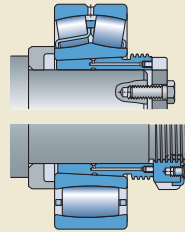
Step 15: Secure the bearing.



Tapered shaft



Adapter sleeve



Withdrawal sleeve

SensorMount

SensorMount enables SKF spherical roller bearings and CARB toroidal roller bearings with a tapered bore and a diameter > 340 mm to be mounted accurately, without measuring either the radial internal clearance or the drive-up distance before or after mounting. Mounting is quick and accurate.

SensorMount uses a sensor, imbedded in the bearing inner ring, and a dedicated hand-held indicator (→ **fig. 34**). The indicator processes the information from the sensor. Inner ring expansion is displayed as the relationship between the clearance reduction (μm) and the bearing bore diameter (mm). The value 0,450 shown on the indicator display is a common limit for bearings operating under normal conditions.

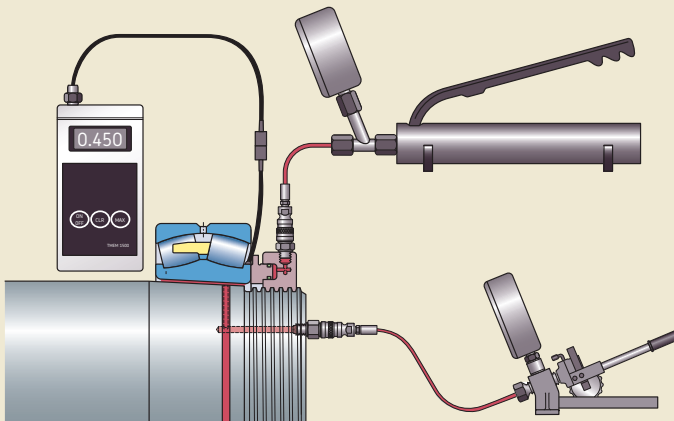
Aspects like bearing size, shaft material, design (solid or hollow) and surface finish does not need any special consideration.

Bearings that will be mounted onto a tapered shaft or adapter sleeve have the sensor on the small bore diameter side of the inner ring – designation prefix ZE, e.g. ZE 23084 CAK/W33. Bearings that will be mounted on a withdrawal sleeve have the sensor on the large bore diameter side – designation prefix ZEB, e.g. ZEB C 3084 KM.

NOTE: Detailed mounting instructions are supplied with the bearing. Alternatively, instructions can be found at www.skf.com/mount.

2

Fig. 34



Hot mounting

The requisite difference in temperature between the bearing ring and shaft or housing depends on the degree of interference and the diameter of the bearing seat.

When heating bearings, temperature control is essential:

- Do not heat open bearings to more than 120 °C (250 °F).
- Do not heat sealed bearings above 80 °C (175 °F) because of their grease fill and/or seal material.

For housings, a moderate increase in temperature, from 20 up to 50 °C (35 up to 90 °F), is normally sufficient, since the degree of interference is seldom large.

Once a bearing has been heated, the objective is to get that bearing in place, up against its shoulder as quickly as possible and keep it there until the bearing has cooled. To do this, SKF recommends using a bearing handling tool and lifting tackle, especially when mounting medium-size and large bearings (→ **figs. 7 to 9** on **page 50**).

CAUTION: When mounting a bearing, never strike it directly with any hard object such as a steel hammer or a chisel, and never apply the mounting force through the rolling elements.

To heat a bearing or housing to the proper temperature quickly and safely, SKF offers a wide assortment of heaters. The following is a listing of available heating techniques and their typical uses.

CAUTION: Never heat a bearing using an open flame (→ **fig. 35**)!

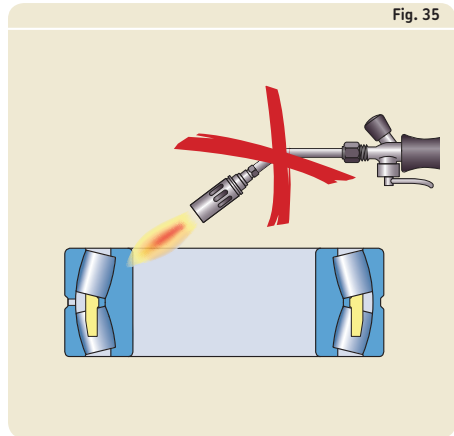


Fig. 35

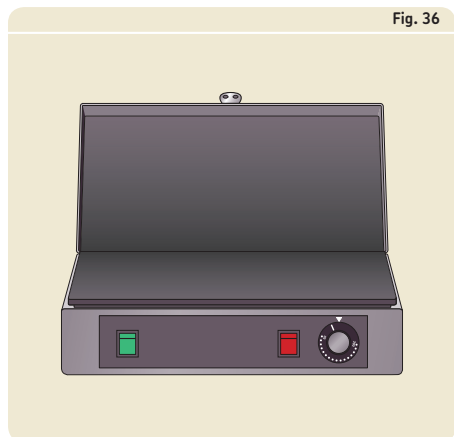


Fig. 36

Electric hot plates

An electric hot plate (→ **fig. 36**) can be used to heat small bearings or small housings. To provide uniform heating, the bearings must be turned over a number of times.

The SKF Electric hot plate is a thermostatically controlled heating device with an adjustable temperature range of 50 to 200 °C (120 to 390 °F).

CAUTION: Sealed bearings should never contact the heating plate directly. Place a ring between the plate and bearing.

Fig. 37

Induction heaters

SKF recommends using an electric induction heater (→ **fig. 37**) to heat rolling bearings. Induction heaters heat bearings evenly within a relatively short time and are particularly safe because the heater and yoke never get hot.

Induction heaters will magnetize a bearing. Therefore, it is important to demagnetize the bearing prior to installation. All SKF induction heaters have an automatic demagnetizing device. They are available in several sizes for heating bearings with a bore diameter from 20 mm and upwards.

Operating instructions are supplied with the induction heaters.

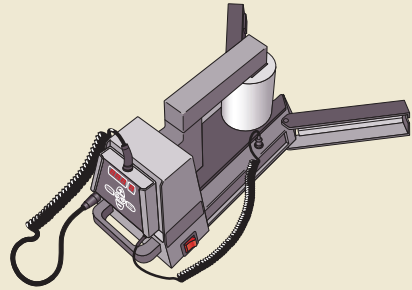


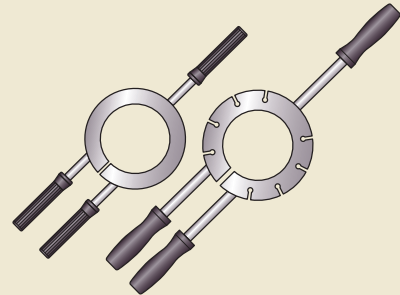
Fig. 38

Aluminium heating rings

Aluminium heating rings (→ **fig. 38**), originally developed for dismantling the inner rings of NU, NJ and NUP cylindrical roller bearings, can also be used for mounting.

SKF aluminium heating rings are available for bearing sizes 204 to 252, 304 to 340 and 406 to 430.

Operating instructions are supplied with the rings.



Mounting rolling bearings

Heating cabinets

Heating cabinets are typically used when a larger number of small bearings or a number of bearings of different sizes as well as small housings have to be heated.

Suitable heating cabinets are equipped with an adjustable thermostat and fan (→ **fig. 39**). The fan circulates the heated air to maintain an even temperature throughout the cabinet.

Infrared radiators

Infrared radiators provide a clean, safe and very simple way to heat small, thin-walled housings. The infrared radiator, encased in a screw cap is placed in the housing bore and switched on. It normally takes only a few minutes to sufficiently heat the housing, because the interference fit between the housing bore and bearing is rarely tight (→ **fig. 40**). After heating, switch off the radiator, remove it from the housing bore and quickly push the cold bearing into position.

Fig. 39

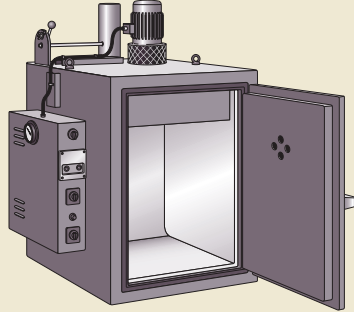
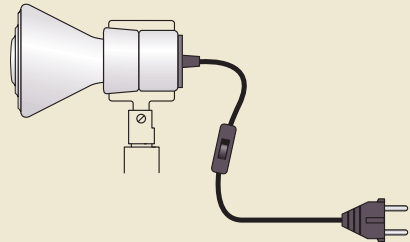


Fig. 40



Heating panels

Flexible heating panels are an excellent and safe solution for heating housings without complicated installations. They are made from several flexible materials and available in a number of types and sizes (→ fig. 41).

Heating panels suit individual heating needs, e.g. they can be used to cover the housing or placed in the housing bore or as a flat bottom heater.

Oil baths

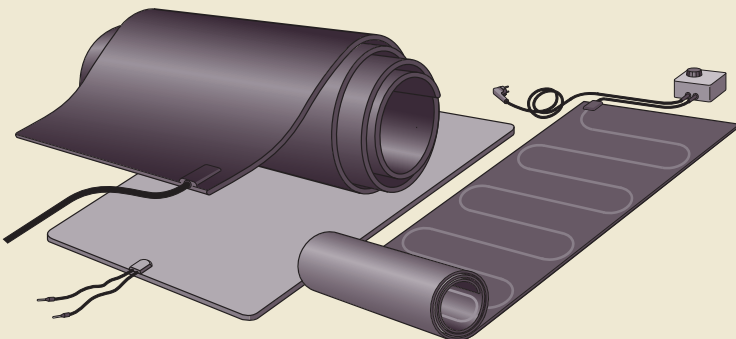
Years ago, oil baths were a popular way to heat bearings and small housings. Today, this method is no longer recommended due to economic, environmental and safety reasons. However, sometimes there is no alternative.

When heating a bearing in an oil bath, some basic rules must be followed. Only use clean oil with a flashpoint above 250 °C (480 °F) and a clean receptacle with an adjustable thermostat. Furthermore, the bearings or bearing rings should never make direct contact with the receptacle. After heating the bearing and before pushing the bearing into position on the shaft, allow the oil adhering to the bearing to drip off and then wipe clean the outside of the bearing.

WARNING

Do not place large heavy bearings on the heating panels as this could create an electrical hazard and may damage the heating elements.

Fig. 41



SKF mounting tools

Using the appropriate mounting tools, applying the right mounting method and following the correct procedures will help prevent premature bearing failures and provide proper bearing performance. For that very reason, the SKF product range of mounting tools includes:

- mechanical tools
- hydraulic tools
- heating equipment
- gloves

An overview of the SKF mounting tools and products is provided in **Appendix J**, starting on **page 416**. For additional information, visit www.mapro.skf.com.

Mechanical tools

SKF supplies a full assortment of mechanical tools, such as bearing fitting tools, and spanners, for all common mounting needs.

The SKF Bearing fitting tool kit consists of 36 impact rings in different sizes to facilitate the mounting of more than 400 different bearings (as well as various seals).

The assortment of SKF spanners comprises hook spanners (including adjustable and special hook spanners), impact spanners and axial lock nut sockets.

Table 2

SKF hydraulic pumps and oil injectors selection guide

Max. working pressure	Pump Designation	Description	Oil container capacity	Connection fitting	Mounting applications
MPa	–	–	cm ³	–	–
50	TMJL 50	Hand operated pump	2 700	G 1/4	All HMV ..E nuts
100	729124 TMJL 100	Hand operated pump Hand operated pump	250 800	G 1/4 G 1/4	Hydraulic nuts ≤ HMV 54E Hydraulic nuts ≤ HMV 92E
150	THAP 150 728619 E	Air-driven pump Hand operated pump	Separate container 2 550	G 3/4 G 1/4	All HMV ..E nuts, oil injection method Hydraulic nuts of all sizes, oil injection method
300	THAP 300E 226400 729101 B TMJE 300	Air-driven pump Hand operated oil injector Hand operated oil injection kit Hand operated oil injection set	Separate container 200 200 200	G 3/4 G 3/4 Several Several	Large pressure joints, oil injection method Oil injection method, adapter and withdrawal sleeves Oil injection method, adapter and withdrawal sleeves Oil injection method, adapter and withdrawal sleeves
400	729101 E	Hand operated oil injection kit	200	G 1/4	Oil injection method, high pressure joints

Hydraulic tools

SKF has developed a comprehensive assortment of hydraulic tools, including hydraulic nuts, hydraulic pumps and oil injectors, to facilitate bearing installation.

SKF hydraulic nuts have the following characteristics:

- In the HMV ..E series, from a thread diameter size 50 up to and including 200 mm, they have a metric thread in accordance with ISO 965-3:1998, tolerance class 6H.
- In the HMV ..E series, from a thread diameter size 205 up to and including 1 000 mm, they have a metric trapezoidal thread in accordance with ISO 2901:1977, tolerance class 7H.
- In the HMVC ..E series, from a thread diameter size 1.967 up to and including 12.5625 in., they have an American National, Form NS, thread in accordance with ANSI B1.1-1974, class 3.
- In the HMVC ..E series, from thread diameter size 13.339 up to and including 37.410 in., they have a General Purpose ACME Thread in accordance with ANSI B 1.5-1957, class 3G.

SKF hydraulic pumps and oil injectors are available in several designs and sizes (→ **table 2**).

SKF also offers an assortment of accessories, such as high-pressure pipes, connectors, hoses and gauges.

Heating equipment

The assortment of SKF heating tools includes induction heaters, electric hot plates and aluminium heating rings, for all common mounting needs.

Gloves

SKF supplies various types of gloves for the safe handling of bearings and components. Four types are available, each suited to specific working conditions:

- special working gloves
- heat resistant gloves
- extreme temperature gloves
- heat and oil resistant gloves

Mounting instructions by bearing type

The mounting methods and tools mentioned under *Preparations prior to mounting*, starting on **page 46**, can generally be used for all types of rolling bearings. However, due to design, size or weight, some bearing types require extra care or specific mounting methods, including:

- single row angular contact ball bearings and tapered roller bearings
- angular contact ball bearings with a two-piece inner ring
- self-aligning ball bearings with protruding balls
- sealed self-aligning ball bearings
- self-aligning ball bearings with an extended inner ring
- single row cylindrical and needle roller bearings with a cage
- multi-row cylindrical and tapered roller bearings
- spherical roller and CARB toroidal roller bearings

Mounting angular contact ball bearings

Single row angular contact ball bearings are typically adjusted against a second bearing in a solid housing, either in a face-to-face or back-to-back bearing arrangement, to balance the counterforces.

Stand-alone bearings

Stand-alone angular contact ball bearings are intended for arrangements where only one bearing is used in each bearing position. Although the widths of the bearing rings are made to very tight tolerances, these bearings are not suitable for mounting immediately adjacent to each other.

Adjusted bearing arrangements with one bearing used in each bearing position are referred to as cross-located arrangements and are generally used for short shafts. The required clearance or preload in these arrangements is achieved during mounting by moving one bearing ring axially.

Adjusting face-to-face bearing arrangements

Whenever possible, SKF recommends adjusting face-to-face bearing arrangements while the shaft is in the vertical position so it will be supported by the lower bearing.

Measure the distance from the side face of the outer ring to side face of the housing (→ **fig. 42**). Determine the requisite shoulder width of the end cover based on the required axial clearance or preload required during operation. If necessary, determine the requisite thickness of the shims to be inserted either between the housing and end cover, or between the outer ring and end cover.

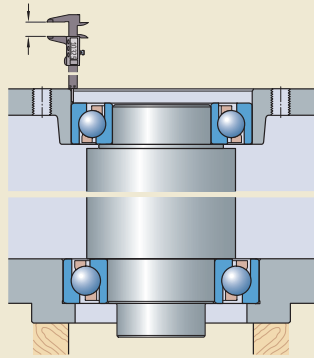
Attach the final machined end cover (and shims) and turn the bearing arrangement back to the horizontal position.

For bearing arrangements with clearance, verify the outcome of the adjustment by measuring the residual axial clearance using a dial indicator (→ **fig. 43**).

NOTE: Direct measurements with a dial indicator are not suitable for preloaded bearing arrangements. In practice, indirect methods are used to adjust the preload, e.g. by fits, displacement measurements or frictional moment control. For assistance in calculating the preload, contact the SKF application engineering service.

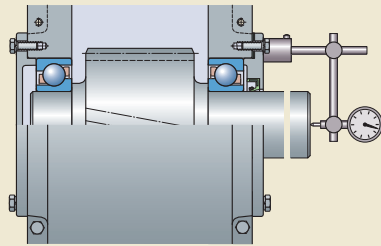
NOTE: During operation, clearance is typically reduced (preload increases) as a result of increased temperatures and temperature differences between the inner and outer rings and other factors such as speeds and loads.

Fig. 42



2

Fig. 43



Mounting rolling bearings

Adjusting back-to-back bearing arrangements

When adjusting back-to-back bearing arrangements, tighten the lock nut or the bolts in the end plate, while occasionally rotating the shaft (→ **fig. 44**).

For bearing arrangements with clearance, measure the residual axial clearance using a dial indicator (→ **fig. 45**). If the residual clearance is too big, tighten the lock nut or end plate bolts. If the residual clearance is too small, dismount the bearings and start again.

NOTE: Direct measurements with a dial indicator are not suitable for preloaded bearing arrangements. In practice, indirect methods are used to adjust the preload, e.g. by fits, displacement measurements or frictional moment control. For assistance with preload calculations, contact the SKF application engineering service.

If a spacer sleeve is used between two bearing inner rings (→ **fig. 46**), the requisite clearance or preload can be set by grinding the width of the spacer sleeve accordingly.

NOTE: During operation, clearance is typically reduced (preload increases) as a result of increased temperatures and temperature differences between the inner and outer rings, and other factors such as speeds, and loads.

Universally matchable bearings and matched bearing sets

When two or more angular contact ball bearings are mounted adjacent to each other, either universally matchable bearings or a matched bearing set should be used. These bearings are specifically manufactured so that when mounted immediately adjacent to each other, a given internal clearance or preload and/or even load distribution will be obtained without the use of shims or similar devices.

Fig. 44

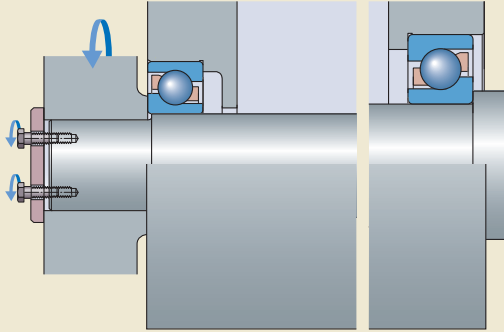


Fig. 45

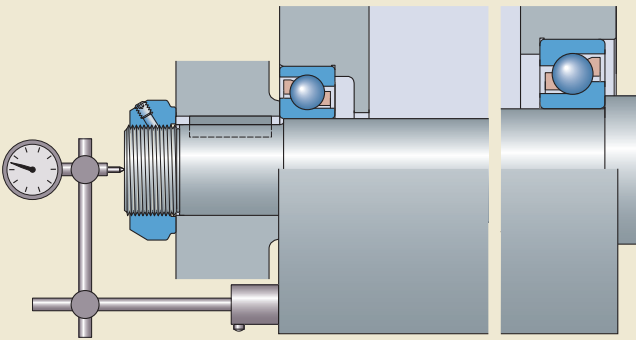
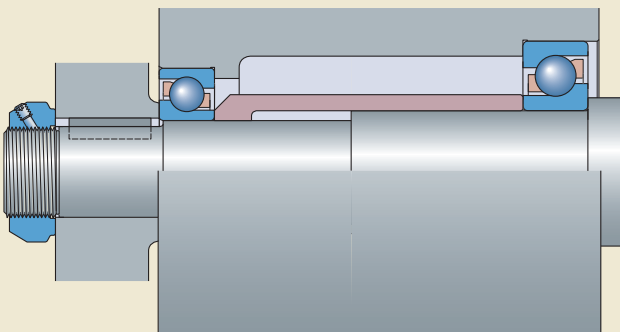


Fig. 46



2

Mounting rolling bearings

Angular contact ball bearings with a two-piece inner ring

For double row angular contact ball bearings with a two-piece inner ring and four-point contact ball bearings, a specific mounting sequence should be followed (→ **fig. 47**).

First, drive the inboard inner ring half into position **(1)**. Then, place the outer ring with ball and cage assembly(ies) onto the mounted inner ring half **(2)**. Finally, drive the outboard inner ring half against the mounted inner ring half **(3)**.

Small inner rings can be mounted with a bearing fitting tool and a dead blow hammer; larger bearings should be heated prior to mounting.

NOTE: SKF Explorer four-point contact ball bearings are marked with a serial number on the side face of the outer ring and both inner ring halves (→ **fig. 48**). An asterisk on one of the outer ring side faces and one of the inner ring halves enables the bearing to be mounted in the same position as originally manufactured.

Fig. 48

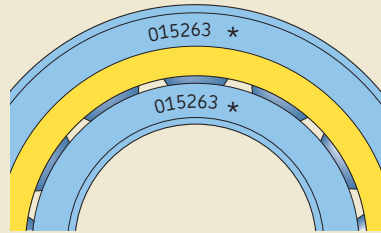
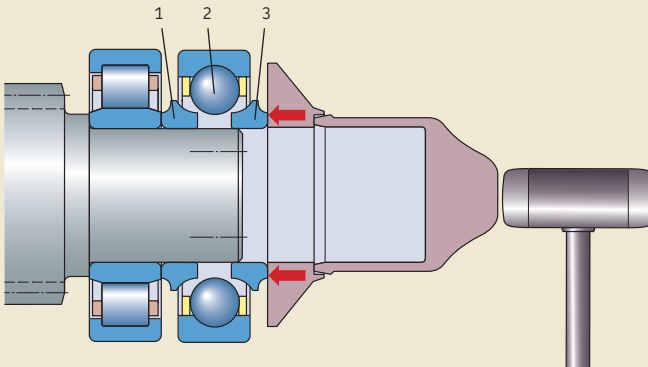


Fig. 47



Mounting self-aligning ball bearings

Basic design bearings with protruding balls

The balls of some self-aligning ball bearings in the 12 series ($d \geq 120$ mm) and 13 series ($d \geq 90$ mm) protrude from the sides of the bearing. This design feature needs to be considered when mounting these bearings.

For bearings with a cylindrical bore, SKF recommends mounting with heat. If the bearing is to be cold mounted, the intermediate mounting ring of the fitting tool must be recessed by at least 3 mm to avoid damaging the balls (→ fig. 49).

If the bearing has a tapered bore, SKF recommends the SKF Drive-up Method (→ page 57), together with a distance ring or an intermediate spacer (→ fig. 50).

Sealed bearings with a tapered bore

When a sealed self-aligning ball bearing is mounted on an adapter sleeve, use an adapter sleeve in the H 3 .. E series. These adapter sleeves are equipped with a KMFE lock nut, which has a recess on the side face to prevent the seal from being damaged (→ fig. 51).

Fig. 49

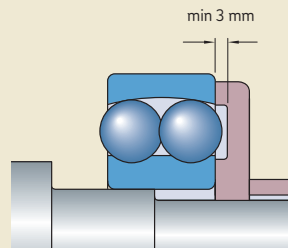


Fig. 50

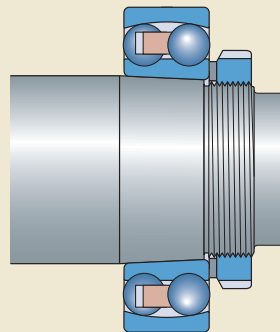
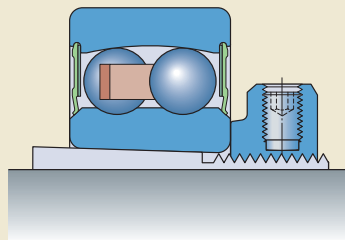
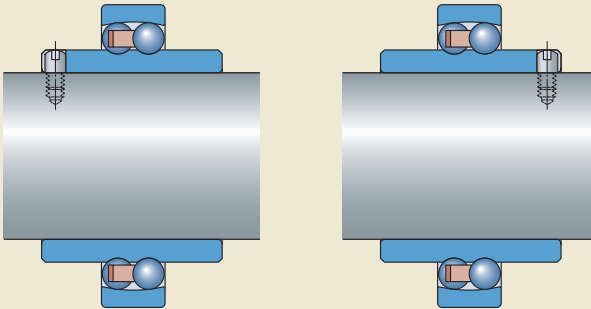


Fig. 51





Bearings with an extended inner ring

Self-aligning ball bearings with an extended inner ring are located axially on the shaft by means of a pin or shouldered screw. When two of these bearings are used to support a shaft, they should be positioned so that the inner ring slots either face each other, or are opposed to each other (→ fig. 52). If this is not the case, the shaft will be axially located in one direction only.

Mounting cylindrical and needle roller bearings

Single row cylindrical and needle roller bearings with a cage

Many cylindrical and needle roller bearings are separable. For NU design cylindrical roller bearings, for example, the outer ring with the roller and cage assembly can be mounted independently of the inner ring, which simplifies assembly.

When mounting an inner ring with or without a roller and cage assembly, SKF recommends mounting with heat. The method used to apply heat depends on the size of the ring (→ *Hot mounting*, starting on page 68).

CAUTION: Apply oil or grease to the rollers and raceways prior to mounting. Rotate the shaft or housing during assembly. Be sure that the roller and cage assembly is not skewed during assembly (→ fig. 53) or damage to the rollers and raceways could result.

Fig. 53

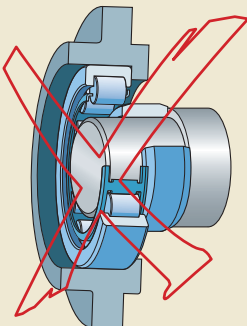


Fig. 54

To prevent skewing during mounting, SKF recommends the following:

- use a mounting sleeve for bearings mounted on horizontal shafts (→ fig. 54)
- use a mounting sleeve and guide rods attached to the housing for bearings mounted on long shafts and where mounting is done in the vertical position (→ fig. 55)

When using a mounting sleeve, the outside diameter of the sleeve should be the same as the raceway diameter of the inner ring and should be machined to tolerance class d10 for cylindrical roller bearings and to tolerance 0/-0,025 mm for needle roller bearings.

CAUTION: When using an induction heater, be sure that the ring is demagnetized before removing it from the heater. All SKF induction heaters have an automatic demagnetization function.

When using an aluminium heating ring (→ fig. 56), coat the inner ring raceway with oxidation-resistant oil, e.g. lubricating oil CLP68, before heating the ring, and remove the oil after installation.

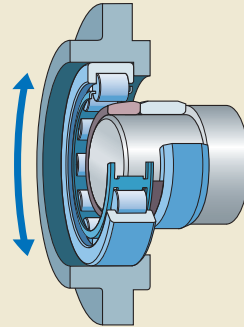


Fig. 55

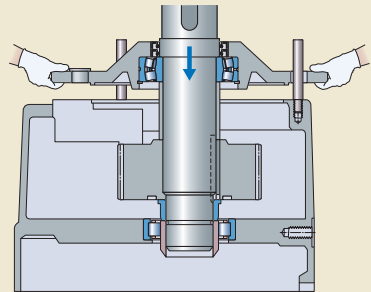
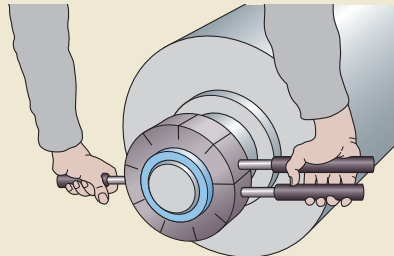


Fig. 56



Mounting rolling bearings

Four-row cylindrical roller bearings

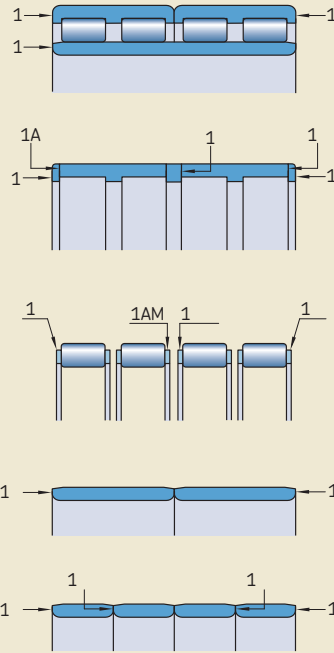
Four-row cylindrical roller bearings are typically used in rolling mills or other heavy applications. They are of separable design with a movable inner ring and are produced in many designs, which differ basically in the number of inner and outer rings as well as in the number of loose or integral flanges on the outer ring.

SKF recommends mounting (and dismounting) the inner ring(s) using a special SKF Fixed induction heater and a specially made mounting sleeve (→ *Mounting a four-row cylindrical roller bearing using a special mounting sleeve*).

During mounting, the individual bearing components must be mounted in the correct order (→ **fig. 57**). In addition, all components of the bearing are marked with the same serial number so that there is no risk of mixing components if several bearings are to be mounted at the same time. The inner rings and inner ring pairs are fully interchangeable and do not necessarily have the same serial number as the other parts.

The side faces of the outer rings are divided into four zones marked I to IV. On each bearing, the position of zone I is also identified by a line across the external surface of the outer ring. When the bearing is mounted for the first time, zone I should typically be positioned in the load zone. Depending on the operating conditions, the outer rings are normally turned 90° after a determined period of service so that a different part of the bearing's outer rings is positioned in the load zone, which extends the service life of the bearing.

Fig. 57



Mounting a four-row cylindrical roller bearing using a special mounting sleeve

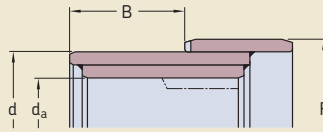
Fig. 58 shows the use of a special mounting sleeve, typically used for a four-row cylindrical roller bearing with a two-piece inner ring and outer ring.

The outside diameter of the sleeve is stepped. The smaller outside diameter corresponds to the bore diameter of the inner ring. The larger diameter corresponds to the diameter of the inner ring raceway. The width of both seats is the same as the width of the inner ring(s). The smaller outside diameter is for mounting the inner ring(s), the larger outside diameter when mounting the outer ring(s) with cage and roller assemblies.

The mounting procedure for the inner rings is as follows (→ **fig. 59**):

- 1 Mount any parts between the inner ring and shaft shoulder.
- 2 Put the first ring on the sleeve.
- 3 Position the sleeve (with the inner ring) on the roll neck support diameter.
- 4 Put the heater in place and heat the inner ring to the required temperature.
- 5 Push the inner ring into position against its abutment.
- 6 Keep pressing until the ring has cooled.
- 7 Remove the sleeve.
- 8 Mount the second inner ring, repeating **steps 2 to 7**.

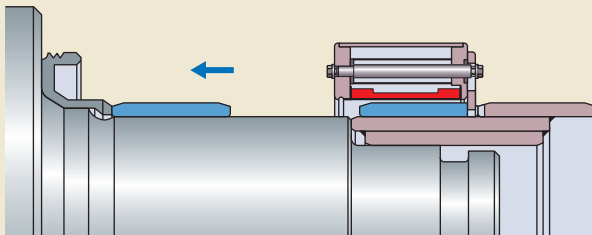
Fig. 58



B = width of inner ring(s)
 F = raceway diameter
 d = inner ring bore
 d_a = sleeve support diameter

2

Fig. 59



Mounting rolling bearings

The mounting procedure for the outer rings is as follows (→ **fig. 60**):

- 1 Lubricate the cage and roller assemblies, and the outer ring raceways with the lubricant to be used.
- 2 Put the first roller assembly, which should be mounted in the housing together with the second assembly, on the large raceway diameter of the mounting sleeve.
- 3 Mount the seals, if any, in the inner cover before it is pushed up against the sealing collar.
- 4 Lubricate the seal lips and take care not to damage the seals.
- 5 Place the sleeve on the shaft and push gently until the complete assembly is in position. Use lifting equipment with a spring suspension to facilitate the positioning of the bearing assembly to the shaft.
- 6 For grease lubricated applications, completely fill the bearing arrangement with grease.
- 7 Mount the outer seals and lock the bearing arrangement onto the shaft.

Mounting tapered roller bearings

Single row tapered roller bearings

A single row tapered roller bearing is typically adjusted against a second bearing, either in a face-to-face or back-to-back bearing arrangement, to balance the counterforces. The clearance or preload in the bearing arrangement is achieved during mounting by moving one bearing ring axially.

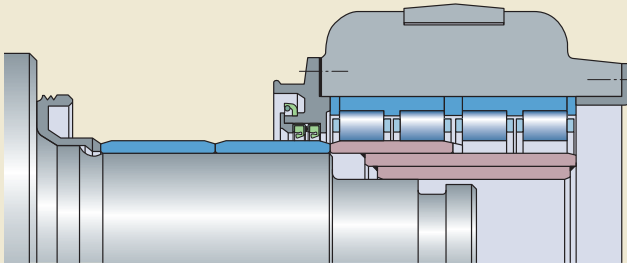
NOTE: During operation, clearance is typically reduced (preload increases) as a result of increased temperatures, temperature differences between the inner and outer rings and other factors such as speeds and loads.

CAUTION: During adjustment, it is important to turn the shaft through several revolutions in both directions to make sure there is proper contact between the roller ends and guide flanges. If there is no proper contact, the resulting clearance/preload will be incorrect, leading to early bearing damage and finally failure.

Adjusting a face-to-face bearing arrangement (inner ring rotation)

Fig. 61 shows a typical bearing arrangement for an intermediate shaft in a split gearbox, using tapered roller bearings mounted face-to-face. The clearance or preload in this arrangement is achieved by moving the outer ring of the bearing on the left side via the centring flange of the cover. The following procedure is simple, reliable and well proven.

Fig. 60



Preparation:

- 1 Use appropriate mounting methods to mount the inner rings (cones) with roller and cage assembly on the shaft. Push the outer rings (cups) over the roller and cage assemblies and place the shaft assembly in the gearbox. Bolt down the cover on the non-adjustment side of the case and turn the case on its side. A proper holding device is required that enables the shaft to rotate.

Determine the required length of the centring flange:

- 2 Rotate the shaft by hand, while pressing down the outer ring of the upper bearing. All rollers in the bearings have to make contact with the guide flange on the inner ring. This is achieved with a few revolutions of the shaft.
- 3 Place the cover. The centring flange of the cover must be too long (→ **fig. 62**, left) for the final outer ring position, or a spacer has to be used (→ **fig. 62**, right). There must be a gap between the cover and case (→ **fig. 62**, dimension x).
- 4 Bolt the cover while turning the shaft until there is a sudden increase in the frictional moment.
- 5 Measure the gap between the cover and case (dimension x).
- 6 Determine the requisite length of the centring flange (or spacer) or the shim thickness:

Length of centring flange or spacer

$$a_f = a_i - x + s \quad \text{for clearance}$$

$$a_f = a_i - x - t \quad \text{for preload}$$

Shim thickness

$$b_f = x + s \quad \text{for clearance}$$

$$b_f = x - t \quad \text{for preload}$$

where

a_i = initial length of the centring flange or spacer

a_f = final length of the centring flange or spacer

b_f = final thickness of the shims

x = measured clearance between the cover and gearbox case

s = clearance value (absolute value)

t = preload value (absolute value)

Final assembly:

- 7 Machine the centring flange or spacer to the required length. Alternatively, insert shims between the cover and case.
- 8 Bolt down the cover.

NOTE: For preload, the housing resilience is not taken into account. If required, refer to the SKF publication *Rolling bearings in industrial gearboxes*.

Fig. 61

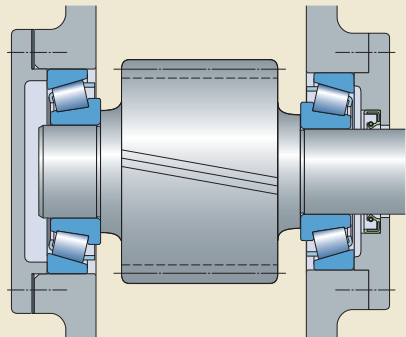
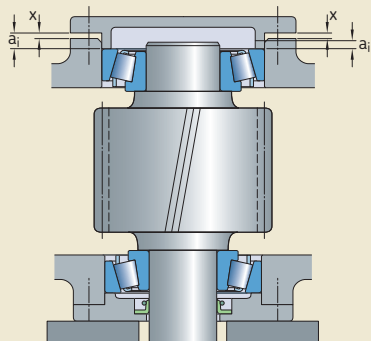


Fig. 62



Mounting rolling bearings

Adjusting a back-to-back bearing arrangement with an adjusting nut (inner ring rotation)

Fig. 63 shows a typical bearing arrangement, using back-to-back mounted tapered roller bearings. The clearance or preload in this arrangement is achieved by moving the inner ring of the bearing on the left side by tightening the adjusting nut. For arrangements requiring axial preload, a value for the tightening angle or a tightening torque value must be provided on the assembly drawing.

Preparation:

- 1 Use appropriate mounting methods to mount the outer rings (cups) into their housing seats and the inboard inner ring (cone) with roller and cage assembly on the shaft. A proper holding device is required, which allows the shaft to rotate.
- 2 Fit together the preassembled shaft and housing. A device may be required to hold the shaft in place.
- 3 Mount the outboard inner ring (cone).
- 4 Mount any components between the outboard cone and the adjusting nut.

Adjustment for clearance:

- 5 Measure axial clearance with a dial indicator. To do this, place the tip of the dial indicator against the shaft end, and push the shaft firmly in one direction while turning it several times. Set the reading to zero. Then push the shaft in the opposite direction and read the measured axial displacement.
- 6 Tighten the adjusting nut slowly. Bearings with a tight fit on the shaft are gradually adjusted until the set value is achieved. To do this, measure the clearance several times.

CAUTION: Do the adjustment in small steps. If too much clearance is taken out of the bearing arrangement, the inner ring has to be withdrawn and adjusted again, which may prove difficult and time-consuming.

Adjustment for preload:

- 7 Tighten the adjusting nut slowly while turning the shaft until there is a sudden increase in the frictional moment.
- 8 Continue to tighten the nut slowly to the set torque value or tightening angle.

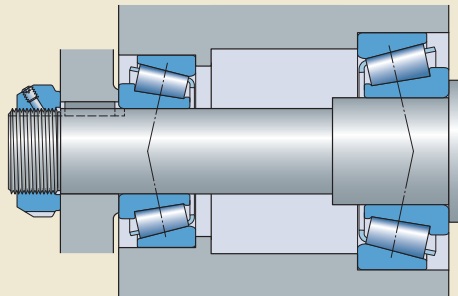


Fig. 63

Fig. 64

Adjusting back-to-back bearing arrangements (vehicle wheel application – two tapered roller bearings without a spacer)

Wheel hub designs differ from one manufacturer to another. However, the correct procedures for installing bearings and seals and assembling the wheel hub remain basically the same. **Fig. 64** shows a typical bearing arrangement. As this is an outer ring rotation application, in most cases the outer rings (cups) have a tight fit, while the inner rings (cones) can have a loose fit on the axle spindle. The clearance or preload in this arrangement is achieved by moving the inner ring of the outboard bearing by tightening the adjusting nut.

CAUTION: Replace the seal each time the hub is removed from the spindle.

- 1 Press both outer rings (cups) into the hub using a suitable tool, such as a sleeve or vertical press (→ **fig. 65**), taking care not to damage the raceways. Make sure that the side face of each outer ring abuts the hub shoulder completely.
- 2 Install the relevant seal or seal components into the hub using a suitable seal installation tool (→ **fig. 66**). Make sure that the seal is straight and that it has bottomed out completely.
- 3 Fit any seal components or spacers on the inboard side of the spindle.
- 4 Prepare the inner ring of the inboard bearing:
 - For grease lubricated applications, apply grease to the roller set and make sure to fill the space between the inner ring raceway and the cage.
 - For oil lubricated bearings, coat the inner ring completely with a thin layer of oil.
- 5 Press the inboard inner ring (cone) onto the spindle, using a suitable tool, such as a sleeve, taking care not to apply any force to the cage and rollers. Make sure that the side face of the inner ring abuts the spindle shoulder or abutment ring completely.
- 6 Install the hub assembly over the spindle, making sure that the hub bore and the centre of the spindle are aligned. Use a mechanical support to facilitate this and avoid damaging the spindle, threads and in particular the seal.
- 7 Prepare the inner ring of the outboard bearing in the same way as the inner ring of the inboard bearing.

2

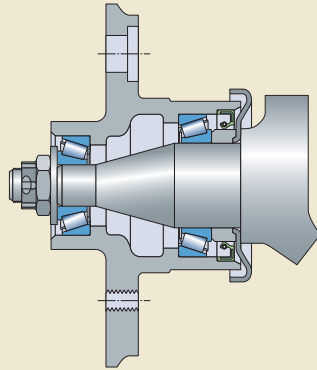


Fig. 65

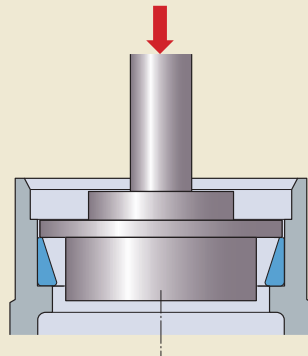
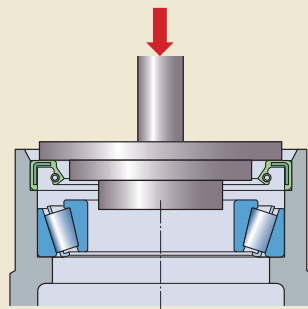


Fig. 66



Mounting rolling bearings

- 8 Press the outboard inner ring with the cage and roller assembly onto the spindle using a suitable tool, such as a sleeve, taking care not to apply any force to the cage and rollers.

CAUTION: Turn the shaft through several revolutions in both directions to make sure there is proper contact between the roller ends and guide flanges. If there is no proper contact, the resulting clearance will be incorrect, leading to early bearing damage and finally failure.

- 9 Fit the washer(s) and the adjusting (castle) nut. Tighten the adjusting nut with a torque wrench to the appropriate torque as described in the vehicle service or maintenance manual. Alternatively, for arrangements requiring axial clearance, tighten the adjusting nut slowly until the bearing frictional moment rapidly increases. Loosen the nut by turning it approximately $1/12$ of a turn (30°) until the bearing arrangement feels "free".
- 10 Remove the hub support.
- 11 Check that the bearing rotates freely. If desired, verify the axial clearance (end play) in the bearing arrangement using a dial indicator as follows:
- 12 Attach the dial indicator (\rightarrow fig. 67), or use a dial indicator with a magnetic base attached at the bottom of the hub or brake drum.
- 13 Adjust the dial indicator so that its plunger or pointer is against the end of the spindle with its line of action approximately parallel to the axis of the spindle. (For aluminium hubs, attach the magnetic base of the indicator to the end of the spindle with the plunger against the hub or brake drum.)
- 14 Set the dial indicator to zero.
- 15 Grasp the wheel assembly at the 3 o'clock and 9 o'clock positions and push it back and forth. Read the axial clearance as the total indicator movement.
- 16 Mount the cover and perform a test run.

Fig. 67

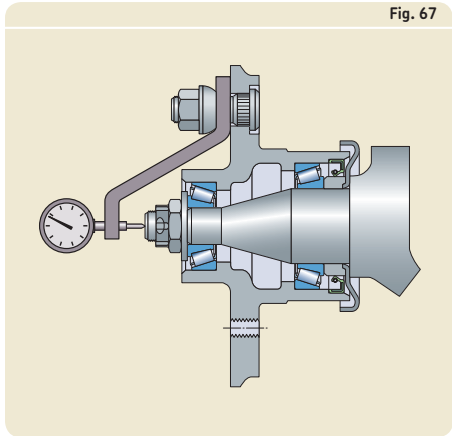


Fig. 68

Double row and multi-row tapered roller bearings

Double row and four-row tapered roller bearings are produced in many designs, which differ basically in the number of outer rings as well as in the number of spacer rings between the inner and outer rings.

When mounting these bearings, the individual bearing components must be mounted in the correct order. Parts that belong together are marked with letters (→ **fig. 68**). In addition, all components of the bearing are marked with the same serial number to avoid the risk of mixing components if several bearings are to be mounted at the same time.

The side faces of the outer rings are divided into four zones, marked I to IV (→ **fig. 69**). On each bearing, the position of zone I is also identified by a line across the external surface of the outer ring. When the bearing is mounted for the first time, zone I should typically be positioned in the load zone. Depending on the operating conditions, the outer rings are normally turned 90° after a determined period of service so that a different part of the bearing outer rings is positioned in the load zone, to extend the service life of the bearing.

For detailed mounting instructions, refer to the publication *SKF Explorer four-row tapered roller bearings, Mounting and maintenance instructions*.

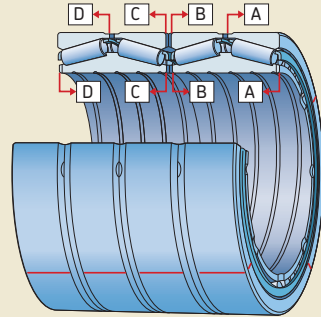
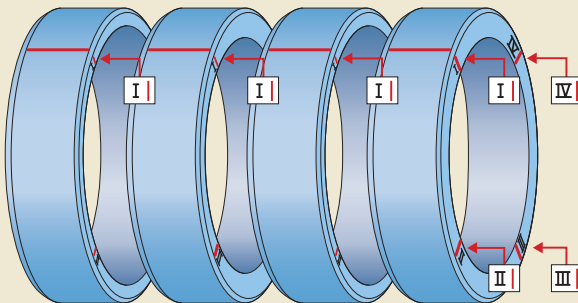


Fig. 69



Mounting rolling bearings

Mounting spherical roller and CARB toroidal roller bearings

Due to the design of spherical roller and CARB toroidal roller bearings, the rings and roller complement may be displaced axially from the normal position during handling. For this reason, SKF recommends mounting spherical roller and CARB toroidal roller bearings when the shaft or housing is in the horizontal position and to rotate the inner ring before mounting, where possible.

When mounting spherical roller and CARB toroidal roller bearings (especially large and heavy ones) when the shaft or housing is in the vertical position, the roller complement together with the inner ring or outer ring will move downward until all clearance has disappeared. Unless proper clearance is maintained during and after installation, the expansion or compression forces resulting from an interference fit on either the inner or outer ring can create a preload.

CAUTION: This preload can cause indentations in the raceways and/or prevent the bearing from turning altogether.

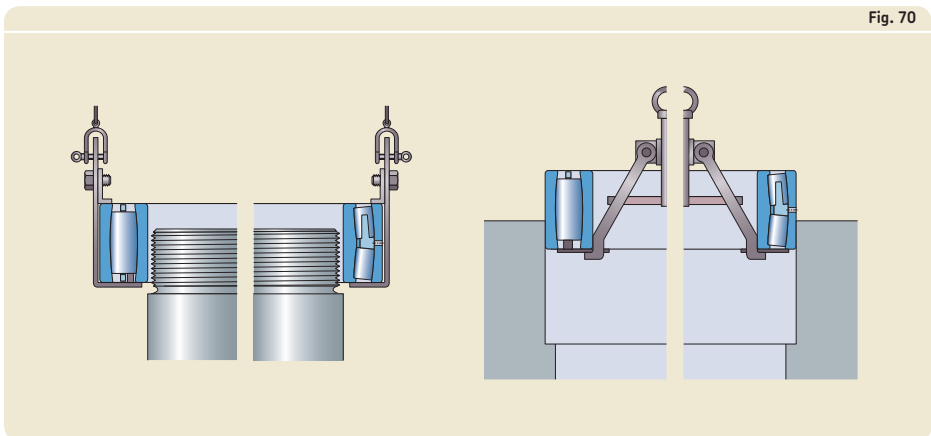
To prevent this preload condition from occurring during vertical mounting, use a bearing handling tool or a special device that keeps the bearing components centrally arranged (→ **fig. 70**).

Sealed spherical roller bearings

Sealed spherical roller bearings typically do not require relubrication. However, when operating conditions are arduous, relubrication might be necessary. Bearings in the lower size range ($d < 100$ mm) have a protective polymer band that covers the lubrication groove and holes in the outer ring. If relubrication is expected, the polymer band must be removed from these bearings before mounting (→ **fig. 71**).

NOTE: For additional information about relubrication, refer to *Relubrication*, starting on **page 192**.

Sealed spherical roller bearings with a tapered bore are preferably mounted using the SKF Drive-up Method (→ *SKF Drive-up Method*, starting on **page 57**).



CARB toroidal roller bearings

Taking axial displacement into consideration

CARB toroidal roller bearings can accommodate axial expansion of the shaft within the bearing. To be sure that these axial displacements of the shaft with respect to the housing can take place, it is necessary to provide adequate space on both sides of the bearing (→ **fig. 72** and see *Abutment and fillet dimensions*, **page 38**).

Normally, the bearing rings are mounted so that they are not displaced relative to each other. However, if considerable thermal changes in shaft length can be expected, the inner ring should be mounted offset relative to the outer ring, in the direction opposite to the expected thermal expansion.

Bearings with a tapered bore can be mounted with modified adapter sleeves and/or lock nuts to prevent the locking device from chafing the adjacent cage. If standard lock nuts are used, a spacer ring may be needed between the bearing inner ring and the lock washer.

The SKF Drive-up Method is especially suitable to mount CARB toroidal roller bearings on a tapered bore (→ *SKF Drive-up Method*, starting on **page 57**).

If information about the required free space, permissible offset position and spacer dimensions (where applicable) are not provided on the arrangement drawing, visit www.skf.com/bearings.

Bearings with a retaining ring

For full complement CARB toroidal roller bearings that have a retaining ring in the outer ring and need to accommodate relatively large axial displacements, make sure that the inner ring can be displaced away from the retaining ring (→ **fig. 73**).

Fig. 71

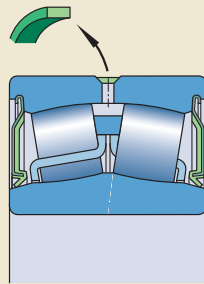


Fig. 72

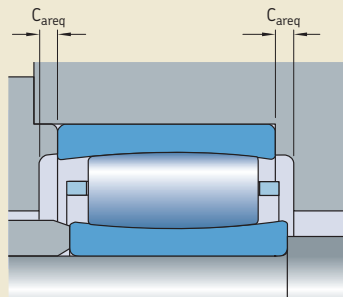
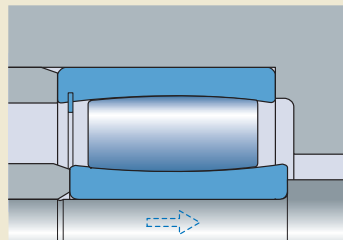


Fig. 73





Mounting bearing units

General	94	Mounting roller bearing units with a cylindrical locking collar	119
What to remember	94	Assembling ball bearing units	121
Preparations prior to mounting	101		
Appropriate tools	102		
Mounting ball bearing units with grub (set) screw locking	104		
Ball bearing units with a cast iron or composite housing	104		
Ball bearing units with a pressed steel housing	105		
Mounting ball bearing units with an eccentric locking collar	106		
Ball bearing units with a cast iron or composite housing	106		
Ball bearing units with a pressed steel housing	108		
Mounting ball bearing units with an adapter sleeve	109		
Mounting SKF ConCentra ball bearing units	111		
SKF ConCentra ball bearing plummer (pillow) block units	111		
SKF ConCentra ball bearing flanged units	113		
Mounting SKF ConCentra roller bearing units	114		
SKF ConCentra roller bearing plummer (pillow) block units	114		
SKF ConCentra roller bearing flanged units	117		

Mounting bearing units

Ge

SKF bearing units are ready-to-mount and ready-to-use units. These units generally consist of an insert ball or roller bearing and a housing manufactured from grey cast iron, sheet steel or composite material. To help achieve maximum service life, they must be installed properly. Use of incorrect procedures or unsuitable tools can reduce service life and damage the bearing units. As precision components, they should be handled carefully when mounting.

Wha

SKF bearing units are available in three different housing styles and, depending on the bearing type and unit size, there is a choice of methods to locate the unit on the shaft. The most common methods are (→ **fig. 1**):

- grub (set) screw locking (**a**)
- single grub (set) screw eccentric locking collar (**b**)
- adapter sleeve locking (**c**)
- SKF ConCentra locking mechanism (**d, e**)
- double grub (set) screw cylindrical collar locking (**f**)

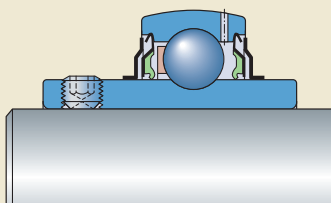
When selecting a replacement unit, match the following elements of the original ball or roller bearing:

- the shaft locking method (→ **fig. 1** and **table 1** on **page 96**)
- the housing style (→ **figs. 2a** to **2t**, starting on **page 95** and **table 2** on **page 100**)
- the sealing method (→ **table 1** on **page 96**)
- the inner ring that can be extended on either one or both sides (ball bearing units)
- the locating or non-locating position (roller bearing units)

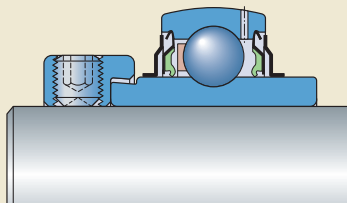
For additional information about SKF maintenance and lubrication products and tools, visit www.skf.com and www.mapro.skf.com.

The SKF Reliability Maintenance Institute (RMI) offers a comprehensive range of training courses (→ *Training*, starting on **page 326**). Contact your local SKF representative for additional information, or visit www.skf.com/services.

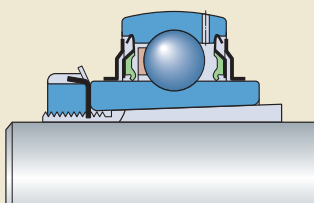
Fig. 1



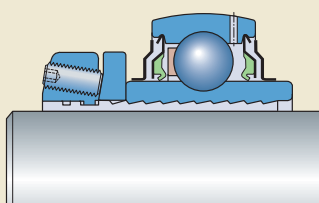
a) Grub (set) screw locking



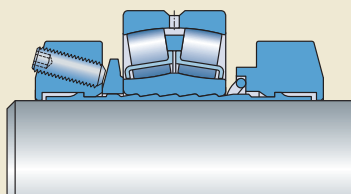
b) Single grub (set) screw eccentric locking collar



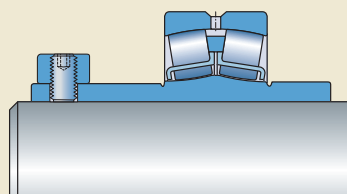
c) Adapter sleeve locking



d) SKF ConCentra locking, ball bearing units



e) SKF ConCentra locking, roller bearing units



f) Double grub (set) screw cylindrical collar locking

3

Mounting bearing units

Table 1

Shaft locking devices, arrangements and seals

Designation suffix	Figure ¹⁾	Description	Complete bearing unit designation (example)
Locking device			
-	1f	Double grub (set) screw cylindrical locking collar	SYR 2.7/16
FM	1b	Single grub (set) screw eccentric locking collar	TU 35 FM
KF	1c	Adapter sleeve	SYJ 65 KF
N	1e	SKF ConCentra locking mechanism	FSYE 3.15/16 N
NTH	1a	Two grub (set) screws in the inner ring	FYTBKC 20 NTH
NTR	1a	Two grub (set) screws in the inner ring	FYKC 30 NTR
PF	1d	SKF ConCentra locking mechanism	SY 45 PF
RM	1a	Two grub (set) screws in the inner ring	SYH 1.15/16 RM
TF	1a	Two grub (set) screws in the inner ring	SYFJ 45 TF
THR	1a	Two grub (set) screws in the inner ring	FYL 25 THR
TR	1a	Two grub (set) screws in the inner ring	SYK 20 TR
WF	1b	Single grub (set) screw eccentric locking collar	FY 60 WF
Arrangement and seals			
-		Non-locating collar mount roller bearing unit	SYR 2.7/16
-		Double-lip seals (standard)	SYR 2.7/16
AH		Ball bearing units for air-handling arrangements	SY 2 TF/AH
F		Locating roller bearing unit for metric shafts	SYT 45 F
H		Locating roller bearing unit for inch shafts	FSYE 3.15/16 NH
L		Non-locating roller bearing unit for metric shafts	SYNT 50 L
TS		Labyrinth seals	SYNT 50 LTS
TF		Radial shaft seals	SYNT 45 FTF
W		Without relubrication features	SYNT 100 FW
-118		Labyrinth seals	SYR 2.7/16 N-118
-3		Radial shaft seals	SYR 2.7/16-3
-18		Labyrinth seals	SYR 2.7/16-18

¹⁾ On page 95

Fig. 2a



Plummer (pillow) block housings
SY, SYH, SYJ, SYM

Fig. 2b



Plummer (pillow) block housings
SYK, SYKC, SYL

Fig. 2c



Plummer (pillow) block housings
SYF, SYFJ

Fig. 2f



Plummer (pillow) block housings
SYNT

Fig. 2d



Plummer (pillow) block housings
SYFL

Fig. 2g



Plummer (pillow) block housings
SYR, SYE

Fig. 2e



Plummer (pillow) block housings
P, S

Fig. 2h



Flanged housings
FY, FYJ, FYM

Mounting bearing units

Fig. 2i



Flanged housings
FYK, FYKC, FYL

Fig. 2l



Flanged housings
FYC

Fig. 2j



Flanged housings
FYT, FYTB, FYTJ, FYTM

Fig. 2m



Flanged housings
F, PF

Fig. 2k



Flanged housings
FYTBK, FYTBKC, FYTL

Fig. 2n



Flanged housings
FT, PFT

Fig. 2o



Flanged housings
PFD

Fig. 2r



Take-up housings
TU, TUJ, TUM

Fig. 2p



Flanged housings
FYE

Fig. 2s



Take-up housings
TUL

Fig. 2q



Flanged housings
FYR

Fig. 2t



Take-up housings
TBR

Housing styles of SKF ball and roller bearing units¹⁾

Housing style	Description
F	Flanged ball bearing unit with a round pressed steel housing
FSYE	Roller bearing plummer (pillow) block unit with a cast housing and four bolt base
FSYR	Roller bearing plummer (pillow) block unit with a cast housing and four bolt base
FT	Ball bearing flanged unit with an oval pressed steel housing
FY	Ball bearing flanged unit with a square flange cast housing
FYC	Ball bearing flanged unit with a round flange cast housing
FYE	Roller bearing flanged unit with a square flange cast housing
FYJ	Ball bearing flanged unit with a square flange cast housing
FYK	Ball bearing flanged unit with a square flange reinforced polyamide housing
FYKC	Ball bearing flanged unit with a square flange reinforced polyamide housing
FYL	Ball bearing flanged unit with a square flange reinforced polyamide housing
FYM	Ball bearing flanged unit with a square flange cast housing
FYNT	Ball bearing flanged unit with a square flange cast housing
FYR	Roller bearing flanged unit with a round flange cast housing
FYRP	Roller bearing flanged unit with a round flange cast housing and machined extension
FYT	Ball bearing flanged unit with an oval flange cast housing
FYTB	Ball bearing flanged unit with an oval flange cast housing
FYTBK	Ball bearing flanged unit with an oval flange reinforced polyamide housing
FYTBKC	Ball bearing flanged unit with an oval flange reinforced polyamide housing
FYTJ	Ball bearing flanged unit with an oval flange cast housing
FYTL	Ball bearing flanged unit with an oval flange reinforced polyamide housing
FYTM	Ball bearing flanged unit with an oval flange cast housing
P	Ball bearing plummer (pillow) block unit with a pressed steel housing
PF	Ball bearing flanged unit with a round flange pressed steel housing
PFD	Ball bearing flanged unit with a triangular flange pressed steel housing
PFT	Ball bearing flanged unit with an oval flange pressed steel housing
S	Ball bearing plummer (pillow) block unit with a pressed steel housing
SY	Ball bearing plummer (pillow) block unit with a cast housing
SYE	Roller bearing plummer (pillow) block unit with a cast housing
SYF	Ball bearing plummer (pillow) block unit with a shortened base cast housing
SYFJ	Ball bearing plummer (pillow) block unit with a shortened base cast housing
SYFL	Ball bearing plummer (pillow) block unit with a shortened base polyester housing
SYH	Ball bearing plummer (pillow) block unit with a cast housing
SYJ	Ball bearing plummer (pillow) block unit with a cast housing
SYK	Ball bearing plummer (pillow) block unit with a reinforced polyamide housing
SYKC	Ball bearing plummer (pillow) block unit with a reinforced polyamide housing
SYL	Ball bearing plummer (pillow) block unit with a polyester housing
SYM	Ball bearing plummer (pillow) block unit with a cast housing
SYNT	Roller bearing plummer (pillow) block unit with a cast housing
SYR	Roller bearing plummer (pillow) block unit with a cast housing
TU	Ball bearing take-up unit with a cast housing
TUJ	Ball bearing take-up unit with a cast housing
TUL	Ball bearing take-up unit with a polyester housing
TUM	Ball bearing take-up unit with a cast housing

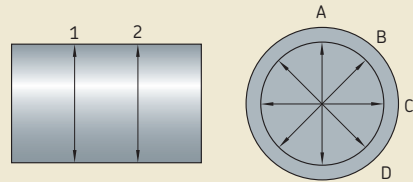
¹⁾ Refer also to **figs. 2a to 2t**, starting on **page 96**.

Preparations prior to mounting

Prior to mounting a bearing unit, do the following:

- Make sure that the shaft is clean and free of any burrs. If not, remove the burrs and chamfer the shaft end with an emery cloth or a fine file. Wipe the shaft clean.
- Check that the shaft bearing seat is within tolerance, preferably at two cross-sections and in four directions (→ **fig. 3**).
- For bearing units that use grub (set) screws, an eccentric locking collar or a cylindrical locking collar, apply a thin coat of light oil to the shaft.
- For bearing units that use an adapter sleeve or SKF ConCentra locking method, use a clean cloth to make sure that the bearing seat on the shaft is dry and free of grease.
- Clean the support surface for the unit and check that the recommended flatness is within IT7 tolerance grade.
- If the unit is used again after removal, make sure that the bearing bore and housing base are clean.
- If shims are needed to elevate the centre height of the unit, make sure that the shim covers the complete contact surface between the unit base and the support surface.
- SKF recommends using 8.8 class bolts or studs and a washer in accordance with ISO 7089:2000 or 7090:2000 and a spring washer, to attach ball and roller bearing units to the base. Hexagonal head bolts in accordance with ISO 4014:1999 are appropriate. Alternatively, hexagonal socket head cap screws in accordance with ISO 4762:1988 can be used.
- Bearing units should not be removed from their original packaging until immediately before they are mounted; this protects the units from contaminants, especially in harsh environments.

Fig. 3



Appropriate tools

To mount SKF ball and roller bearing units, the only tools required are:

- a hexagonal key or torque key to tighten the grub (set) screws in the inner ring or the locking collar as specified in **table 3**
- a hook spanner to tighten adapter sleeve lock nuts as specified in **table 4**

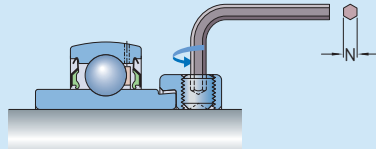
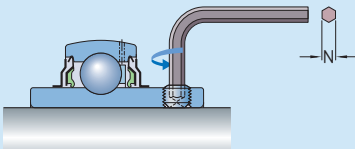
- a torque wrench or hexagonal key to tighten the attachment screws, bolts or nuts

A 3L key in accordance with ISO 2936:2001 is supplied with each SKF ConCentra ball or roller bearing unit, together with a torque indicator (→ **fig. 21** on **page 113**).

Hook spanners are part of the comprehensive assortment of SKF mounting tools and products (→ **Appendix J**, starting on **page 416**).

Table 3

Hexagonal keys and recommended tightening torque values for ball bearing units with grub (set) screw locking or collar locking



Shaft diameter		Hexagonal key size	Tightening torque
d over	incl.		
mm/inch	mm/inch	Nm (in.lbf)	

Shaft diameter		Hexagonal key size	Tightening torque
d over	incl.		
mm/inch	mm/inch	Nm (in.lbf)	

Ball bearing units grub (set) screw locking

Units with the designation suffixes TF and TR (excluding those series listed below)

–	35	3	4 (35)
35	45	4	6,5 (58)
45	65	5	16,5 (146)
65	100	6	28,5 (252)

–	5/8	3/32	4 (35)
5/8	1 3/16	1/8	4 (35)
1 3/16	1 3/4	5/32	6,5 (58)
1 3/4	2 11/16	3/16	16,5 (146)
2 11/16	2 15/16	7/32	28,5 (252)

Units in the SYM .. TF, FYM .. TF and TUM .. TF series

–	1	1/8	4 (35)
1	1 1/2	5/32	6,5 (58)
1 1/2	2 3/16	3/16	16,5 (146)
2 3/16	3	7/32	28,5 (252)

Units with the designation suffix RM

–	45	3	4 (35)
45	50	4	6,5 (58)
–	5/8	3/32	4 (35)
5/8	1 3/16	1/8	4 (35)
1 3/16	1 3/4	5/32	6,5 (58)
1 3/4	2 11/16	3/16	16,5 (146)
2 11/16	2 15/16	7/32	28,5 (252)

Ball bearing units with an eccentric locking collar

Units with the designation suffixes FM and WF

–	25	3	4 (35)
25	30	4	6,5 (58)
30	65	5	16,5 (146)

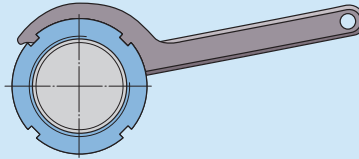
–	5/8	3/32	4 (35)
5/8	1	1/8	4 (35)
1	1 15/16	5/32	6,5 (58)
1 15/16	3	3/16	16,5 (146)

Roller bearing units with cylindrical collar locking

1 3/16	2 3/16	3/8	28,5 (252)
2 3/16	3 1/2	1/2	70 (620)
3 1/2	4	5/8	149,7 (1 325)
4	4 15/16	5/8	149,7 (1 325)

Table 4

Hook spanners and tightening torque values for ball bearing units in the SYJ .. KF, FYJ .. KF and FYTJ .. KF series, mounted with an adapter sleeve



Shaft diameter		Bearing unit Bore diameter	Appropriate adapter sleeve Designation	Appropriate hook spanner					
d				Designation	Tightening torque				
mm	inch	mm	–		–	min	max	min	max
				Nm		in.lbf			
19,050	3/4	25	HE 2305	HN 5-6	13	17	115	150	
20	–	25	H 2305	HN 5-6	13	17	115	150	
23,812	15/16	30	HA 2306	HN 5-6	22	28	195	248	
25	–	30	H 2306	HN 5-6	22	28	195	248	
25,400	1	30	HE 2306	HN 5-6	22	28	195	248	
30	–	35	H 2307	HN 7	27	33	239	292	
30,162	1 3/16	35	HA 2307	HN 7	27	33	239	292	
31,750	1 1/4	40	HE 2308	HN 8-9	35	45	310	398	
35	–	40	H 2308	HN 8-9	35	45	310	398	
36,512	1 7/16	45	HA 2309	HN 8-9	45	55	398	487	
38,100	1 1/2	45	HE 2309	HN 8-9	45	55	398	487	
40	–	45	H 2309	HN 8-9	45	55	398	487	
41,275	1 5/8	50	HS 2310	HN 10-11	55	65	487	575	
42,862	1 13/16	50	HA 2310	HN 10-11	55	65	487	575	
44,450	1 3/4	50	HE 2310	HN 10-11	55	65	487	575	
45	–	50	H 2310	HN 10-11	55	65	487	575	
49,212	1 15/16	55	HA 2311 B	HN 10-11	65	85	575	752	
50	–	55	H 2311	HN 10-11	65	85	575	752	
50,800	2	55	HE 2311	HN 10-11	65	85	575	752	
53,975	2 1/8	60	HS 2312	HN 12-13	85	115	752	1018	
55	–	60	H 2312	HN 12-13	85	115	752	1018	
55,562	2 3/16	65	HA 2313	HN 12-13	110	150	974	1328	
57,150	2 1/4	65	HE 2313	HN 12-13	110	150	974	1328	
60	–	65	H 2313	HN 12-13	110	150	974	1328	
60,325	2 3/8	65	HS 2313	HN 12-13	110	150	974	1328	

Mounting ball bearing units with grub (set) screw locking

Ball bearing units with a cast iron or composite housing

When mounting ball bearing units with a cast iron or composite housing (→ **figs. 2a, 2b, 2c, 2d, 2h, 2i, 2j, 2k, 2l, 2r** and **2s** on **pages 96 to 99**) that have grub (set) screw locking (→ **fig. 1a, page 95**), carefully follow the guidelines provided under *Preparations prior to mounting* on **page 101** as well as the additional guidelines below:

- 1 Mount any components located between the two bearing units onto the shaft.
- 2 **a)** Plummer (pillow) block units: Slide a unit onto each shaft end with the locking device facing outward. Carefully align both units and tighten the attachment bolts using the recommended torque values listed in **table 5**.
b) Flanged units: Support the shaft in the mounting position between the machine walls. Slide a unit onto each shaft end with the locking device facing outward. If not provided with a shoulder, carefully align both units and tighten the attachment bolts using the recommended torque values listed in **table 5**.

c) Take-up units: Slide a unit onto each shaft end with the locking device facing outward. Install the shaft/units assembly into the take-up frames and connect the adjustment screws via the cast hole in the units. Carefully align both units.

NOTE: When relubrication of the unit is required, the maximum permissible misalignment of the shaft relative to the unit is 2°. Otherwise, misalignment of up to 5° can be accommodated.

- 3 Align the shaft in the bearing arrangement axially (→ **fig. 4**).
- 4 Tighten the grub (set) screws in the inner ring (→ **fig. 5**) of both units to the tightening torque values listed in **table 3** on **page 102**.
- 5 If possible, check that the bearing arrangement can freely rotate by turning the shaft a few times.
- 6 If applicable, snap the end cover(s) into place.

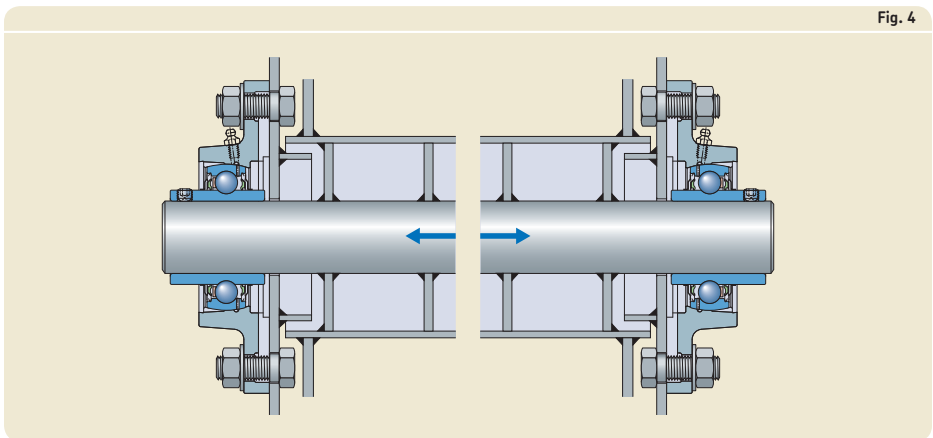
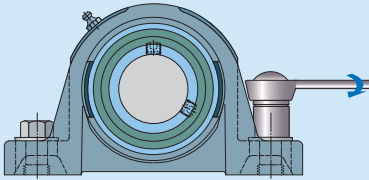


Fig. 4

Table 5

Recommended tightening torque values for attachment bolts or nuts



Bolt size	Tightening torque	
	Nm	ft.lbf
mm/inch		
6	9	7
8	22	16
10	45	34
12	80	60
16	200	150
20	385	285
24	665	485
3/8	28	21
1/2	95	70
5/8	185	135
3/4	320	235
7/8	515	380
1	770	570

Ball bearing units with a pressed steel housing

When mounting ball bearing units with a pressed steel housing (→ figs. 2e, 2m, 2n and 2o on pages 97 to 99) that have grub (set) screw locking (→ fig. 1a, page 95), carefully follow the guidelines provided under *Preparations prior to mounting* on page 101 as well as the additional guidelines below:

3

- 1 Mount any components located between the two bearing units onto the shaft.
- 2 a) Plummer (pillow) block units: Place the bases of the housings on their support surfaces. Slide a bearing with the locking device facing outward onto each shaft end and lay the shaft with the bearings on the housing bases.

NOTE: If the unit has a rubber seating ring (cartridge), first install this ring on the bearing outside diameter (→ fig. 6).

b) Flanged units: Place one housing half into position on the machine walls, support the shaft in the mounting position between the machine walls and slide a bearing with the locking device facing outward onto each shaft end.

- 3 Place a housing cap or the second housing half over each bearing (→ fig. 7, page 106) and fit the attachment bolts or nuts, but do not tighten them.



Fig. 5

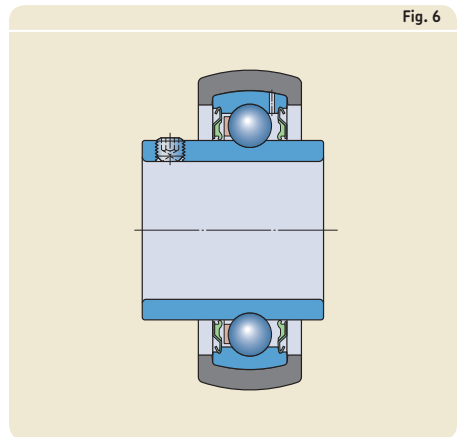


Fig. 6

- Carefully align both housings using the shaft and tighten the attachment bolts using the recommended torque values listed in **table 5** on **page 105**.

NOTE: When relubrication of the unit is required, the maximum permissible misalignment of the shaft relative to the unit is 2° . Otherwise, misalignment of up to 5° can be accommodated.

CAUTION: Units with a pressed steel housing cannot compensate for misalignment once the attachment bolts or nuts have been fully tightened, unless the plummer (pillow) block units are equipped with a rubber seating ring (cartridge).

- If possible, align the shaft in the bearing arrangement axially (\rightarrow **fig. 4** on **page 104**) and turn it a few times.
- Tighten the grub (set) screws in the inner ring of both units to the tightening torque values listed in **table 3** on **page 102**.
- If possible, check that the bearing arrangement can freely rotate by turning the shaft a few times.



Fig. 7

Mounting ball bearing units with an eccentric locking collar

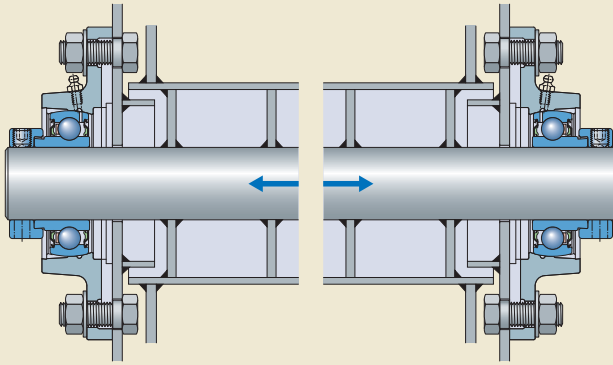
Ball bearing units with a cast iron or composite housing

When mounting ball bearing units with a cast iron or composite housing (\rightarrow **figs. 2a, 2c, 2h, 2j, 2l** and **2r** on **pages 96 to 99**) and an eccentric locking collar (\rightarrow **fig. 1b, page 95**), carefully follow the guidelines provided under *Preparations prior to mounting* on **page 101** as well as the additional guidelines below:

- Mount any components located between the two bearing units onto the shaft.
- Remove the eccentric locking collars.
- a) Plummer (pillow) block units:** Slide a unit onto each shaft end with the locking device facing outward. Carefully align both units and tighten the attachment bolts in both units using the recommended torque values listed in **table 5** on **page 105**.
 - b) Flanged units:** Position the shaft between the machine walls. Slide a unit onto each shaft end with the locking device facing outward. If not provided with a shoulder, carefully align both units and tighten the attachment bolts using the recommended torque values listed in **table 5** on **page 105**.
 - c) Take-up units:** Slide a unit onto each shaft end with the locking device facing outward. Install the shaft/units assembly into take-up frames and connect the adjustment screws via the cast hole in the units. Carefully align both units.

NOTE: When relubrication of the unit is required, the maximum permissible misalignment of the shaft relative to the units is 2° . Otherwise, misalignment of up to 5° can be accommodated.

Fig. 8



- 4 Align the shaft in the bearing arrangement axially (→ **fig. 8**).
- 5 Place an eccentric locking collar on the inner ring extension of each unit and get it finger tight in the main direction of rotation (→ **fig. 9**). Then tighten the locking collar using either a hook spanner with a stud engaging the hole in the circumference of the collar (→ **fig. 10**) or a hammer and drift punch. Tighten the grub (set) screws in the locking collar of each unit to the tightening torque values listed in **table 3** on **page 102**.
- 6 If possible, check that the bearing arrangement can freely rotate by turning the shaft a few times.
- 7 If applicable, snap the end cover(s) into place.

Fig. 9



Fig. 10



Mounting bearing units

Ball bearing units with a pressed steel housing

When mounting ball bearing units with a pressed steel housing (→ **figs. 2e, 2m, 2n** and **2o** on **pages 97 to 99**) and an eccentric locking collar (→ **fig. 1b, page 95**), carefully follow the guidelines provided under *Preparations prior to mounting* on **page 101** as well as the additional guidelines below:

- 1 Mount any components located between the two bearing units onto the shaft.
- 2 Remove the locking collars.
- 3 a) Plummer (pillow) block units: Place the bases of the housings on their support surfaces. Slide a bearing with the locking device facing outward onto each shaft end and place the bearings into the lower half of the units.

NOTE: If the unit has a rubber seating ring (cartridge), first install this ring on the bearing outside diameter (→ **fig. 11**).

b) Flanged units: Position the shaft between the machine walls. Slide a unit onto each shaft end with the locking device facing outward.

- 4 Place a housing cap or the second housing half over each bearing (→ **fig. 12**) and fit the attachment bolts or nuts, but do not tighten them.
- 5 Carefully align both housings, e.g. using the shaft, and tighten the attachment bolts using the recommended torque values listed in **table 5** on **page 105**.

NOTE: When relubrication of the unit is required, the maximum permissible misalignment of the shaft relative to the unit is 2° . Otherwise, misalignment of up to 5° can be accommodated.

CAUTION: Units with a pressed steel housing cannot compensate for misalignment once the attachment bolts or nuts have been fully tightened, unless the plummer (pillow) block units are equipped with a rubber seating ring (cartridge).

- 6 If possible, align the shaft in the bearing arrangement axially (→ **fig. 8** on **page 107**) and turn it a few times.

Fig. 11

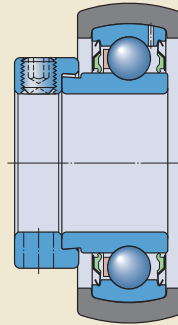


Fig. 12



- 7 Place an eccentric locking collar on the inner ring extension of each unit and snug tightening them in the main direction of rotation. Tighten the locking collar to its final position using either a hook spanner with a stud engaging the hole in the circumference of the collar or a hammer and drift punch. Tighten the grub (set) screw in the locking collar of each unit to the tightening torque values listed in **table 3** on **page 102**.
- 8 If applicable, check that the bearing arrangement can freely rotate by turning the shaft a few times.

Mounting ball bearing units with an adapter sleeve

When mounting ball bearing plummer (pillow) block units with an adapter sleeve (→ **fig. 1c**, **page 95**), carefully follow the guidelines provided under *Preparations prior to mounting* on **page 101** as well as the additional guidelines below:

- 1 Mount any components located between the two bearing units onto the shaft.
- 2 Determine the position of the adapter sleeves on the shaft (→ **fig. 13**).

NOTE: Take into consideration that during assembly, the unit will be displaced axially on the adapter sleeve along the shaft. In case of a stepped shaft, the position of the unit on the shaft is determined by the abutment, which considerably simplifies mounting.

- 3 Remove the nut and the lock washer from the adapter sleeves.
- 4 Expand each adapter sleeve slightly by inserting a screwdriver in the slot of the sleeve (→ **fig. 14**). Then, slide them with the thread facing outward, along the shaft, into position.
- 5 Position the first bearing unit at its location on the adapter sleeve.
- 6 Place the lock washer in position and tighten the lock nut until the inner ring, sleeve and shaft make proper contact.
- 7 Further tighten the lock nut either with a hook spanner to a tightening angle of about 70° (→ **fig. 15**) or with a torque wrench to the recommended tightening torque values (→ **table 4** on **page 103**). Make sure that while tightening the nut, the sleeve does not rotate on the shaft. While tightening, the shaft will move axially according to the axial displacement of the unit on its tapered sleeve seat.

Fig. 13

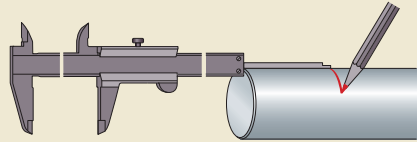


Fig. 14



Fig. 15



Mounting bearing units

- 8 Locate the unit on the sleeve by bending a tab on the lock washer in one of the slots provided around the circumference of the nut (→ **fig. 16**).
- 9 Fit the attachment bolts or nuts, but do not tighten them.
- 10 Position the bearing unit at the other end of the shaft at its location on the sleeve.
- 11 Repeat **steps 6** through **9**. When doing this, the unit should be able to move on the adapter sleeve along the shaft according to its axial displacement on the tapered sleeve seat.
- 12 Carefully align both units.

NOTE: When relubrication of the unit is required, the maximum permissible misalignment of the shaft relative to the units is 2° . Otherwise, misalignment of up to 5° can be accommodated.

- 13 Tighten the attachment bolts or nuts using the recommended torque values listed in **table 5** on **page 105**.
- 14 If applicable, check that the bearing arrangement can freely rotate by turning the shaft a few times.
- 15 If applicable, snap the end cover(s) into place.

To mount ball bearing flanged housing units with an adapter sleeve, contact the SKF application engineering service.



Fig. 16

Mounting SKF ConCentra ball bearing units

CAUTION: Never try to disassemble the unit. Furthermore, never tighten the grub (set) screws in the mounting collar unless the unit is mounted on a shaft. Doing so will damage the SKF ConCentra stepped sleeve.

SKF ConCentra ball bearing plummer (pillow) block units

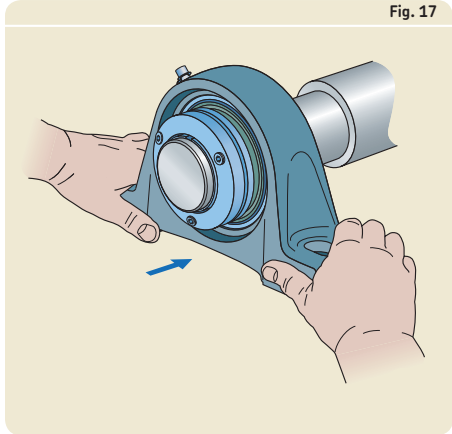
When mounting SKF ConCentra ball bearing plummer (pillow) block units (→ **fig. 1d, page 95**), carefully follow the guidelines provided under *Preparations prior to mounting* on **page 101** as well as the additional guidelines below:

- 1 Mount any components located between the two bearing units onto the shaft.
- 2 With the mounting collar facing outward, slide a unit onto each shaft end (→ **fig. 17**).
- 3 Position the first bearing unit at its correct location and fit the attachment bolts, but do not tighten them.

NOTE: Take into consideration that during assembly, the unit will be displaced axially on the SKF ConCentra stepped sleeve along the shaft (→ **fig. 18**).

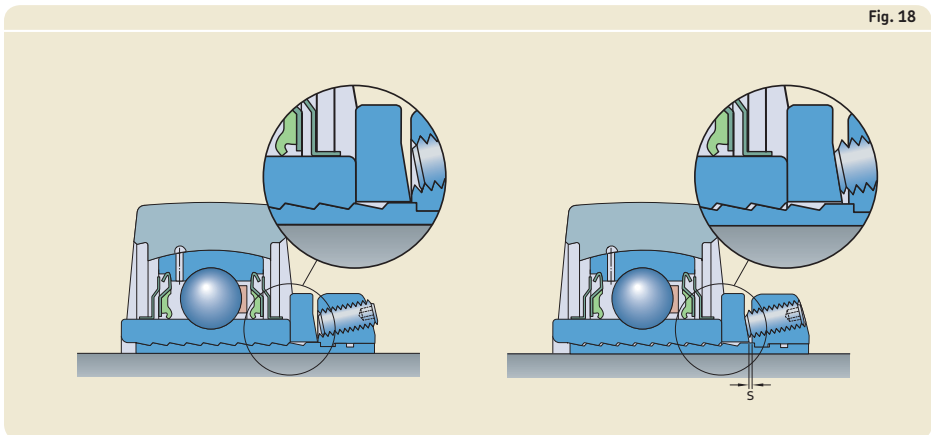
- 4 Position the mounting collar so that there is no grub (set) screw facing the split in the sleeve.

Fig. 17



3

Fig. 18



Mounting bearing units

- 5 Use the short end of the supplied hexagonal key and tighten the grub (set) screws finger tight (→ **fig. 19**).
- 6 Use the long end of the hexagonal key for tightening the screws a total of $1/2$ turn by alternating in two increments ($1/4$ turn and $1/4$ turn) according to the mounting pattern (→ **fig. 20**), starting with the screw opposite the split in the sleeve.
- 7 Mount the supplied red torque indicator on the short end of the hexagonal key (→ **fig. 21**) and tighten the screws until the hexagonal key comes in contact with the torque indicator (→ **fig. 22**). If a torque wrench is used, apply the recommended tightening torque value of 7,4 Nm (5.5 ft.lbf).
- 8 Align the unit and tighten the attachment bolts or nuts using the recommended torque values listed in **table 5** on **page 105**.
- 9 Position the bearing unit at the other end of the shaft. Fit the attachment bolts or nuts, but do not tighten them.
- 10 Repeat **steps 4** through **7**. When doing this, the unit must be able to move axially along the shaft, according to its axial displacement "s" on the SKF ConCentra sleeve (→ **fig. 18** on **page 111**).
- 11 Carefully align the shaft.

NOTE: When relubrication of the unit is required, the maximum permissible misalignment of the shaft relative to the units is 2° . Otherwise, misalignment of up to 5° can be accommodated.

- 12 Tighten the attachment bolts or nuts using the recommended torque values listed in **table 5** on **page 105**.
- 13 If possible, check that the bearing arrangement can freely rotate by turning the shaft a few times.

Fig. 19

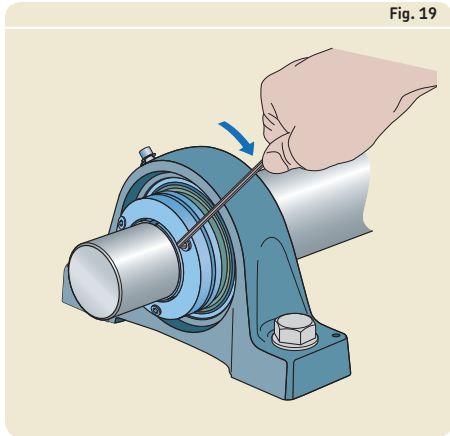
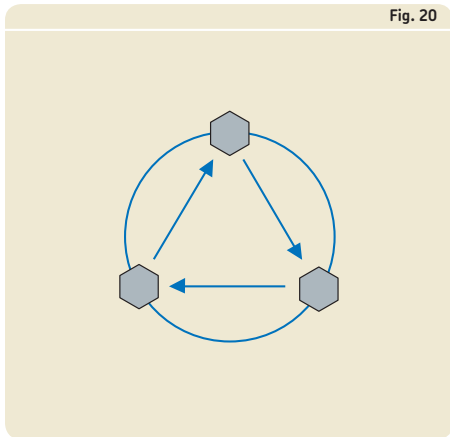
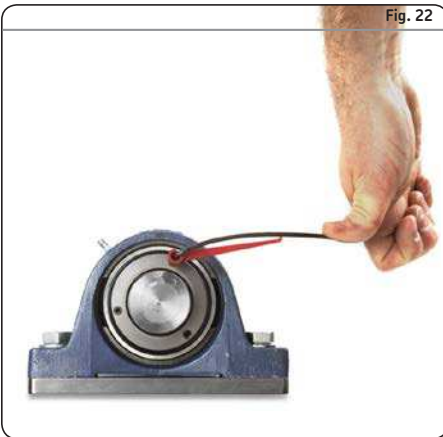


Fig. 20





SKF ConCentra ball bearing flanged units

When mounting SKF ConCentra ball bearing flanged units (→ **fig. 1d, page 95**), carefully follow the guidelines provided under *Preparations prior to mounting* on **page 101** as well as the additional guidelines below:

- 1 Mount any components located between the two bearing units onto the shaft.
- 2 Support the shaft in mounting position between the machine walls.
- 3 With the mounting collar facing outward, slide a unit onto each shaft end.

NOTE: Take into consideration that during assembly, the unit will be displaced axially on the SKF ConCentra stepped sleeve along the shaft (→ **fig. 18, page 111**).

- 4 Place the first bearing unit at its correct location and tighten the attachment bolts or nuts using the recommended torque values listed in **table 5** on **page 105**.
- 5 Position the mounting collar so that there is no grub (set) screw facing the split in the sleeve.
- 6 Use the short end of the supplied hexagonal key and tighten the grub (set) screws to finger tightness.
- 7 Use the long end of the hexagonal key for tightening the screws a total of $\frac{1}{2}$ turn by alternating in two increments ($\frac{1}{4}$ turn and $\frac{1}{4}$ turn) according to the mounting pattern (→ **fig. 20**) starting with the screw opposite the split in the sleeve.
- 8 Mount the supplied red torque indicator on the short end of the hexagonal key (→ **fig. 21**) and tighten the screws until the hexagonal key comes in contact with the torque indicator. If a torque wrench is used, apply the recommended tightening torque value of 7,4 Nm (5.5 ft.lbf).
- 9 Place the bearing unit at the other end of the shaft at its correct location. Fit the attachment bolts or nuts, but do not tighten them.

Mounting bearing units

- 10 Repeat **steps 5** through **8**. When doing this, the unit must be able to move axially along the shaft (→ **fig. 23**) according to its axial displacement “s” on the SKF ConCentra sleeve (→ **fig. 18** on **page 111**).
- 11 Carefully align the shaft.

NOTE: When relubrication of the unit is required, the maximum permissible misalignment of the shaft relative to the units is 2°. Otherwise, misalignment of up to 5° can be accommodated.

- 12 Tighten the attachment bolts or nuts using the recommended torque values listed in **table 5** on **page 105**.
- 13 If possible, check that the bearing arrangement can freely rotate by turning the shaft a few times.

Mounting SKF ConCentra roller bearing units

CAUTION: Never try to disassemble the unit. Furthermore, never tighten the grub (set) screws in the mounting collar unless the unit is mounted on a shaft. Doing so will damage the SKF ConCentra stepped sleeve.

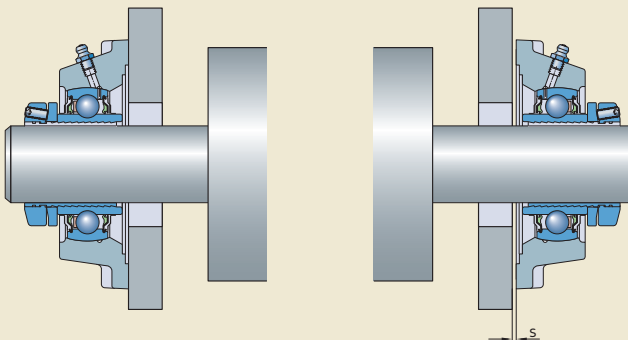
SKF ConCentra roller bearing plummer (pillow) block units

When mounting SKF ConCentra roller bearing plummer (pillow) block units (→ **fig. 1e**, **page 95**), carefully follow the guidelines provided under *Preparations prior to mounting* on **page 101** as well as the additional guidelines below:

- 1 Mount any components located between the two bearing units onto the shaft.
- 2 Determine the position of the locating and non-locating unit on the shaft. The locating unit should always be on the drive side.
- 3 With the mounting collar facing outward, slide a unit onto each shaft end (→ **fig. 24**).

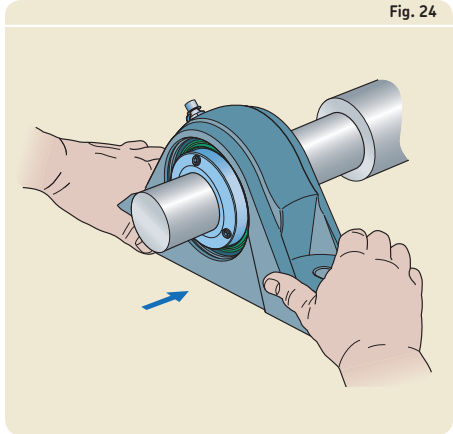
NOTE: Take into consideration that during assembly, the unit will be displaced axially on the SKF ConCentra stepped sleeve along the shaft (→ **fig. 25**).

Fig. 23



- 4 Fit the attachment bolts or nuts, but do not tighten them.
- 5 Position the locating bearing unit axially on the shaft and align the bearing unit on the support surface. SYNT units have vertical markings at the ends of the housing base to facilitate this (→ **fig. 26**).
- 6 Lock the locating bearing unit on the shaft.

Fig. 24



3

Fig. 26

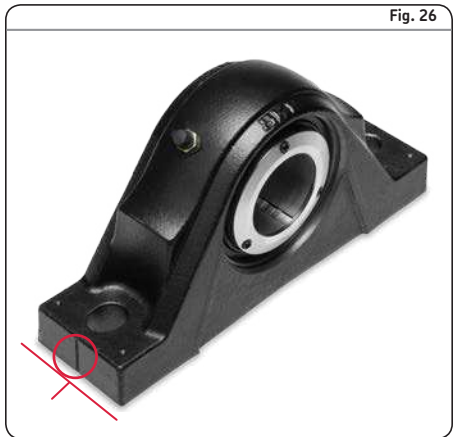
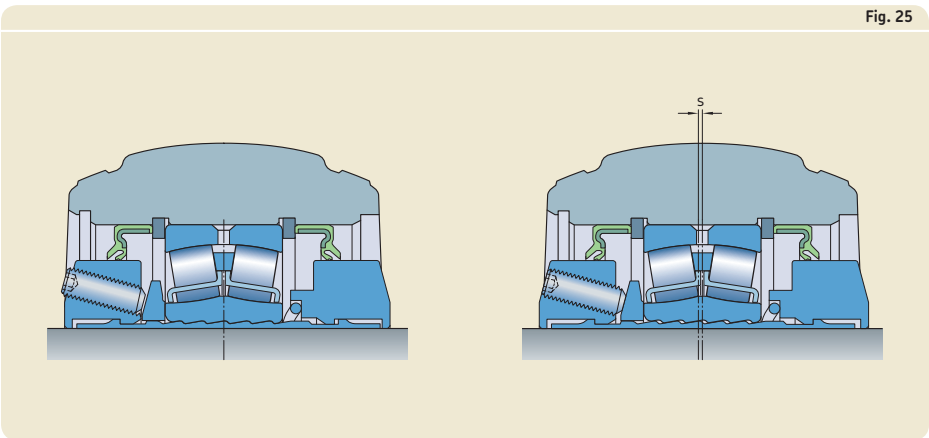


Fig. 25



Mounting bearing units

- 7 Position the mounting collar so that there is no grub (set) screw facing the split in the sleeve. Use the short end of the supplied hexagonal key and tighten each screw to finger tightness. Follow the mounting pattern (→ **fig. 27**), starting with the screw opposite the split in the sleeve. Mount the supplied red torque indicator on the short end of the hexagonal key (→ **fig. 21** on **page 113**) and tighten the screw until the hexagonal key comes in contact with the torque indicator (→ **fig. 28**). When applying a torque wrench to tighten the grub (set) screws (→ **fig. 29**), use a 3 mm bit. Following the mounting pattern, first tighten the screws to finger tightness. Then continue to tighten each screw once again to the recommended tightening torque value of 7,4 Nm (5.5 ft.lbf).
 - 8 Check once again the alignment of the locating unit. The maximum permissible misalignment of the shaft relative to the units is 1,5°.
 - 9 Find the middle of the bearing seat in the non-locating unit. Support the shaft. Grip the collars at both ends of the unloaded insert bearing and move it from one end position in the housing to the other while the housing is fixed. If only thermal elongation of the shaft is expected, SKF recommends that the end position of the bearing is placed toward the locating bearing (→ **fig. 30**).
- NOTE:** Take into consideration that during assembly, the unit will be displaced axially on the SKF ConCentra stepped sleeve along the shaft (→ **fig. 25** on **page 115**).
- 10 Lock the non-locating bearing on the shaft as in **step 7**.
 - 11 Carefully align the unit. Tighten the attachment bolts using the recommended torque values listed in **table 5** on **page 105**.
 - 12 If possible, check that the bearing arrangement can freely rotate by turning the shaft a few times.
 - 13 If applicable, snap the end cover into place.

Fig. 27

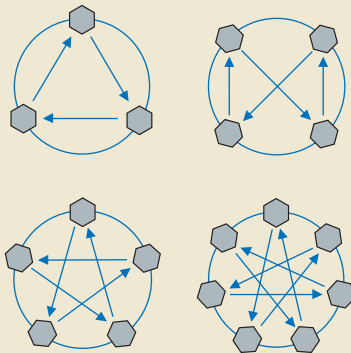


Fig. 28



Fig. 29



SKF ConCentra roller bearing flanged units

When mounting SKF ConCentra roller bearing flanged units (→ **fig. 1e, page 95**), carefully read the guidelines provided under *Preparations prior to mounting* on **page 101** as well as the additional guidelines below:

- 1 Mount any components located between the two bearing units onto the shaft.
- 2 Determine the position of the locating and non-locating unit on the shaft. The locating unit should always be on the drive side.
- 3 Support the shaft in mounting position between the machine walls.
- 4 With the mounting collar facing outward, slide a unit into position onto each shaft end.

NOTE: Take into consideration that during assembly, the unit will be displaced axially on the SKF ConCentra stepped sleeve along the shaft.

- 5 Fit the attachment bolts or nuts, but do not tighten them (→ **fig. 31**).

Fig. 31

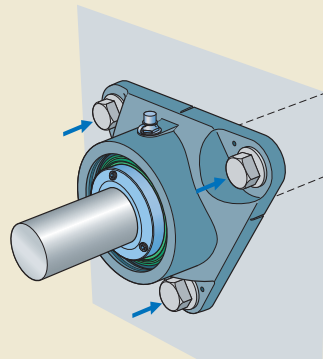
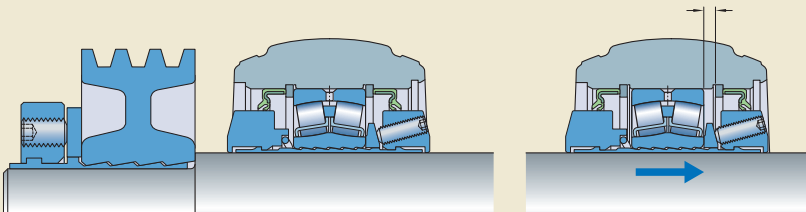


Fig. 30



Mounting bearing units

- 6 Lock the locating bearing on the shaft. Position the mounting collar so that there is no grub (set) screw facing the split in the sleeve. Use the short end of the supplied hexagonal key and tighten the grub (set) screws to finger tightness. Use the long end of the hexagonal key for tightening the screws a total of $\frac{1}{2}$ turn by alternating in two increments ($\frac{1}{4}$ turn and $\frac{1}{4}$ turn) according to the mounting pattern (→ **fig. 27** on **page 116**), starting with the screw opposite the split in the sleeve. Mount the supplied red torque indicator on the short end of the hexagonal key and tighten the screws until the hexagonal key comes in contact with the torque indicator (→ **fig. 32**). If a torque wrench is used (→ **fig. 33**), apply the recommended tightening torque value of 7,4 Nm (5.5 ft.lbf).
- 7 Check once again the alignment of the locating unit. The maximum permissible misalignment of the shaft relative to the units is $1,5^\circ$.
- 8 Find the middle of the bearing seat in the non-locating unit. Support the shaft. Grip a collar of the unloaded insert bearing and move it from one end position in the housing to the other while the housing is fixed. If only thermal elongation of the shaft is expected, SKF recommends that the end position of the bearing is placed toward the locating bearing.

NOTE: Take into consideration that during assembly, the unit will be displaced axially on the SKF ConCentra stepped sleeve along the shaft.

- 9 Lock the non-locating bearing on the shaft as in **step 6**.
- 10 Carefully align the unit. Tighten the attachment bolts using the recommended torque values listed in **table 5** on **page 105**.
- 11 If possible, check that the bearing arrangement can freely rotate by turning the shaft a few times.
- 12 If applicable, snap the end cover into the housing bore recess.

Fig. 32

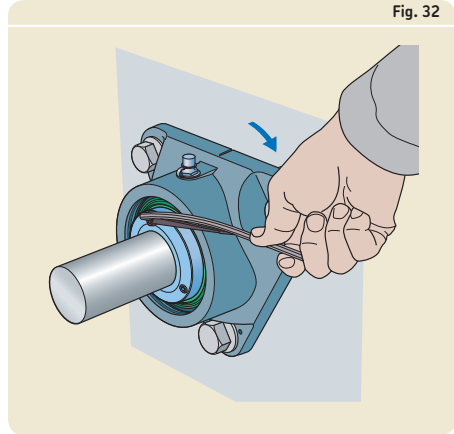
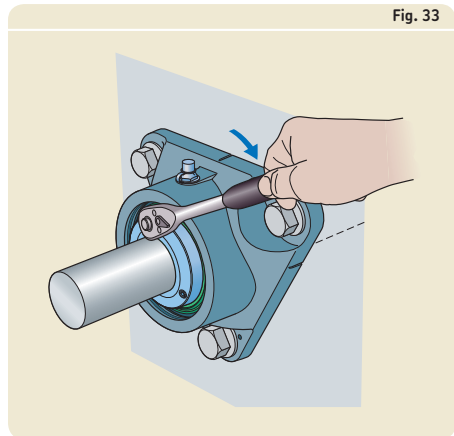


Fig. 33

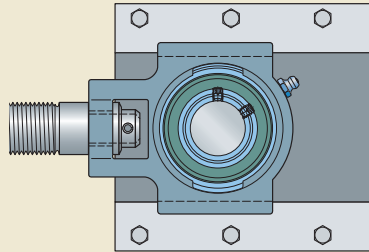


Mounting roller bearing units with a cylindrical locking collar

When mounting roller bearing units with a cylindrical locking collar (→ **fig. 1f**, **page 95**), carefully follow the guidelines provided under *Preparations prior to mounting* on **page 101** as well as the additional guidelines below:

- 1 Determine the position of the locating and non-locating unit on the shaft. The locating unit should always be on the drive side.
- 2 Mount any components located between the two bearing units onto the shaft.
- 3 a) Plummer (pillow) block units: Slide a unit onto each shaft end with the locking device facing outward. Carefully align both units. Fit the attachment bolts and tighten them using the recommended torque values listed in **table 5** on **page 105**. The maximum permissible misalignment of the shaft relative to the units is $1,5^\circ$.
b) Flanged units: Support the shaft in mounting position between the machine walls. Slide a unit onto each shaft end. If not provided with a shoulder, carefully align both units. Fit the attachment bolts and tighten them using the recommended torque values listed in **table 5** on **page 105**. The maximum permissible misalignment of the shaft relative to the units is $1,5^\circ$.
c) Take-up units: Slide a unit onto each shaft end with the locking device facing outward. Install the shaft/units assembly into take-up frames and connect the adjustment screws via the cast hole in the units (→ **fig. 34**). Carefully align both units. The maximum permissible misalignment of the shaft relative to the units is $1,5^\circ$.
- 4 Align the shaft in the bearing arrangement axially.
- 5 Tighten both grub (set) screws in the cylindrical locking collar that grip the shaft through drilled holes in the inner ring of the locating unit to the tightening torque values listed in **table 3** on **page 102**.

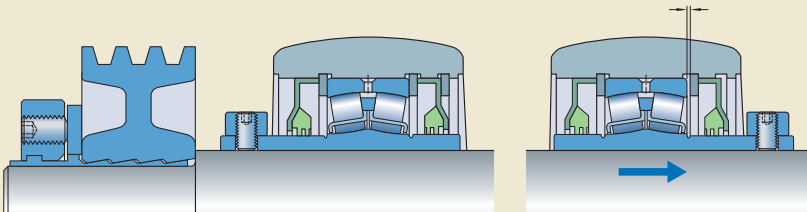
Fig. 34



Mounting bearing units

- 6 Find the middle of the bearing seat in the non-locating unit by supporting the shaft and by moving the unloaded insert bearing from one end position in the housing to the other. If only thermal elongation of the shaft is expected, SKF recommends that the end position of the bearing is placed toward the locating bearing (→ **fig. 35**).
- 7 Lock the non-locating bearing on the shaft as in **step 3**.
- 8 If applicable, check that the bearing arrangement can freely rotate by turning the shaft a few times.

Fig. 35



Assembling ball bearing units

Where Y-bearings and Y-housings made of grey cast iron or composite material are not supplied as units, it is necessary to first assemble them. To do so, the bearing should be inserted into the filling slot in the housing bore (→ **fig. 36**) – for ball bearings with an eccentric locking collar, first remove the locking collar. A round piece of wood or a piece of pipe, etc. can be used to swivel the bearing into its position with the locking device facing the same direction as the filling slots (→ **fig. 37**).

CAUTION: When inserting the bearing, make sure that the lubrication hole at the side of the locking device and the filling slots in the housing do not coincide (→ **fig. 38**).

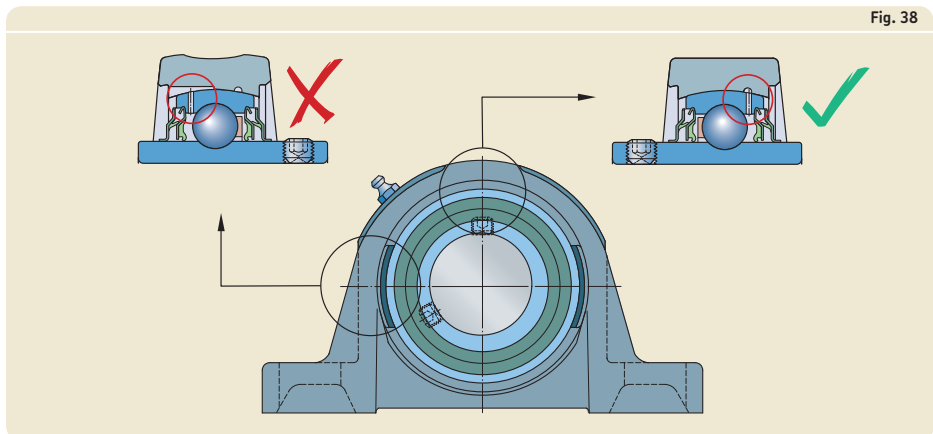
Fig. 36

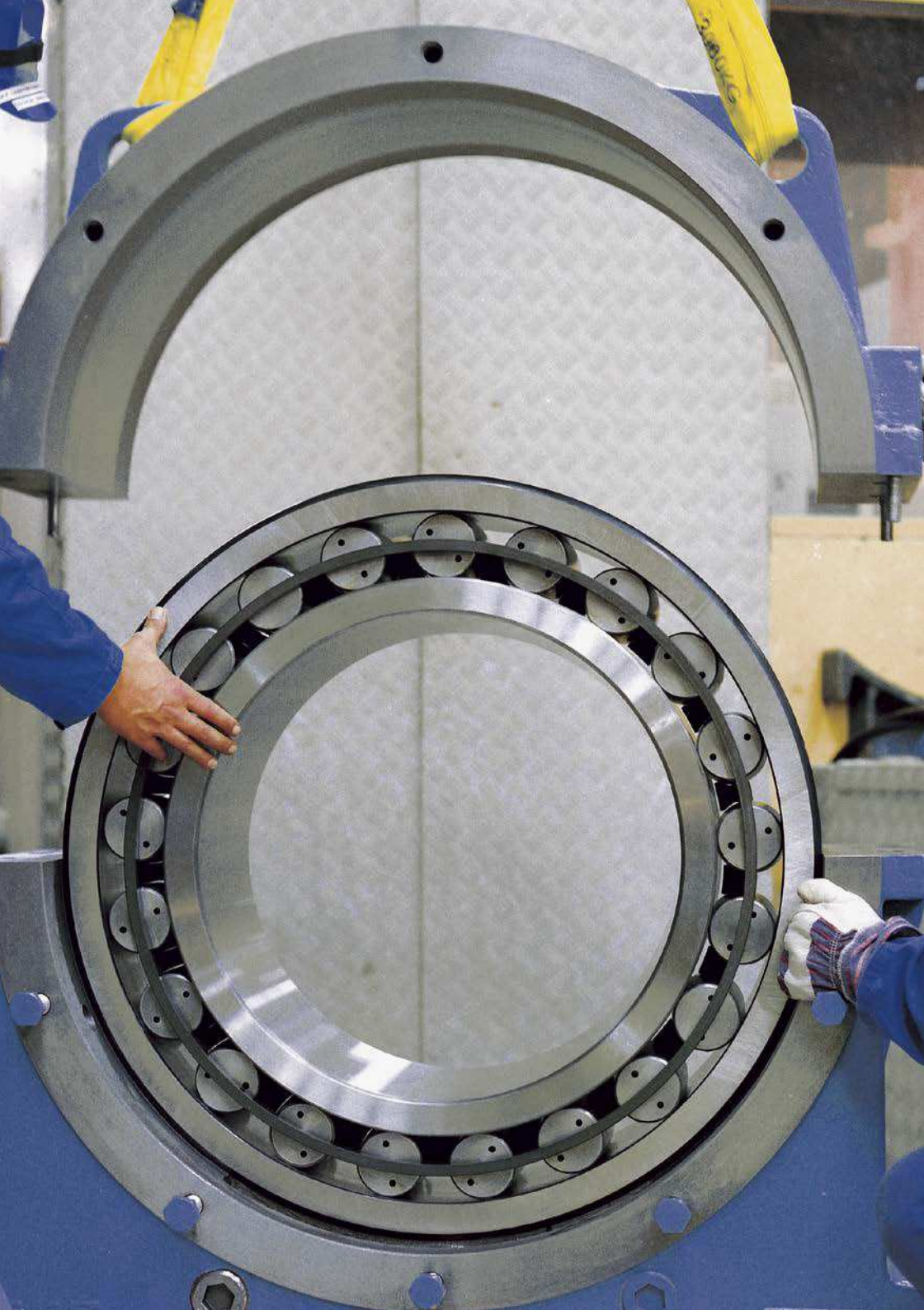


Fig. 37



Fig. 38





Mounting bearing housings

Introduction	124
Selecting replacement parts	124
Preparations prior to mounting	130
Using shims	130
Bolts	131
Using locating (stabilizing) rings	132
Using end covers	133
Installing split or solid seals	133
Mounting standard split plummer (pillow) block housings	134
Mounting SONL plummer (pillow) block housings	137

Introduction

The SKF standard assortment of bearing housings includes:

- split plummer (pillow) block housings
- one-piece plummer (pillow) block housings
- flanged housings
- take-up housings

SKF bearing housings are generally made of grey cast iron. The most popular plummer (pillow) block housings are also available in spheroidal graphite cast iron or cast steel for applications where extra strength is required. The bearing housings are intended primarily for self-aligning ball bearings, spherical roller bearings and CARB toroidal roller bearings.

Most SKF bearing housings are supplied together with mounting instructions. Information about how to mount and assemble split plummer (pillow) block housings is also included in this chapter. Contact the SKF application engineering service for information about mounting special SKF housings for specific applications such as:

- conveyors and drums
- converters
- tube mills and rotary furnaces
- paper machines
- wind turbines
- pinions of open gears

Selecting replacement parts

SKF bearing housings are available in a wide range of styles. They can be used with various seals and for different bearing arrangements. Consequently, care should be taken when selecting a replacement housing. A new housing should match the original part with regard to:

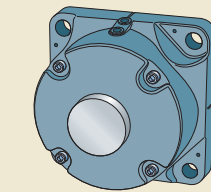
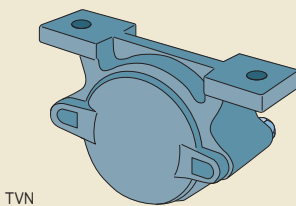
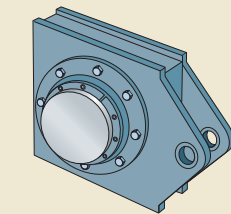
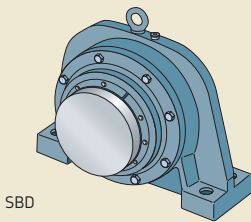
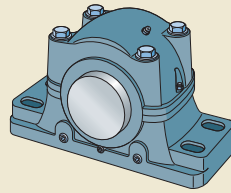
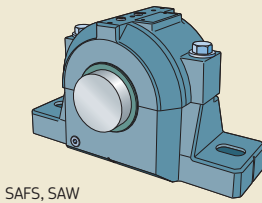
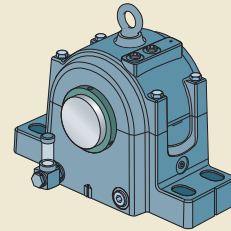
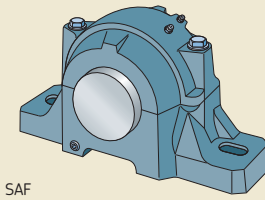
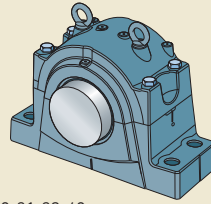
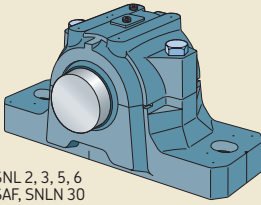
- the housing style (→ **fig. 1** and **table 1, page 126**)
- the housing variant (→ **table 2, page 127**)
- the bearing arrangement (→ **fig. 2, page 127**)
- the sealing solution and configuration (→ **table 3, page 128** and **fig. 3, page 129**)

For additional information about SKF maintenance and lubrication products and tools, visit www.skf.com and www.mapro.skf.com.

For detailed mounting instructions for specific bearing housings, visit www.skf.com/mount.

The SKF Reliability Maintenance Institute (RMI) offers a comprehensive range of training courses (→ *Training*, starting on **page 326**). Contact your local SKF representative for additional information, or visit www.skf.com/services.

Fig. 1



SKF standard bearing housings

Housings Style/series	Replaced by	Description
FNL		Cast iron flanged housing, having a triangular or square form, with double-lip seals
FSNL		Cast iron split plummer (pillow) block housing with four bolt holes in the base
SAF		Cast iron split plummer (pillow) block housing
SAFS		Cast steel split plummer (pillow) block housing
SAW		Cast iron split plummer (pillow) block housing
SBD		Cast iron one-piece plummer (pillow) block housing with labyrinth seals
SD 31	SNL 31	Cast iron split plummer (pillow) block housing
SDAF		Cast iron split plummer (pillow) block housing
SDG	SNL 32, 40	Cast iron split plummer (pillow) block housing
SDJC 31	SNL 31	Cast iron split plummer (pillow) block housing
SN 2, 3, 5, 6	SNL 2, 3, 5, 6	Cast iron split plummer (pillow) block housing
SN 30	SNLN 30	Cast iron split plummer (pillow) block housing
SNA 2, 3, 5, 6	SNL 2, 3, 5, 6	Cast iron split plummer (pillow) block housing
SNH 2, 3, 5, 6	SNL 2, 3, 5, 6	Cast iron split plummer (pillow) block housing
SNL 2, 3, 5, 6		Cast iron split plummer (pillow) block housing
SNLN 30		Cast iron split plummer (pillow) block housing
SNL 30		Cast iron split plummer (pillow) block housing
SNL 31		Cast iron split plummer (pillow) block housing
SNL 32		Cast iron split plummer (pillow) block housing
SNL 40		Cast iron split plummer (pillow) block housing
SNLD		Spheroidal graphite cast iron split plummer (pillow) block housing
SNT		Cast steel split plummer (pillow) block housing with felt seals
SOFN	SONL	Cast iron split plummer (pillow) block housing for oil lubrication, with labyrinth seals
SONL		Cast iron split plummer (pillow) block housing for oil lubrication, with labyrinth seals
SSNHD	SSNLD	Spheroidal graphite cast iron split plummer (pillow) block housing with a solid base
SSNLD		Spheroidal graphite cast iron split plummer (pillow) block housing with a solid base
THD		Cast iron take-up housing
TVN		One-piece cast iron plummer (pillow) block housing with felt seals
7225	FNL	Cast iron flanged housing, having a triangular or square form, with felt seals

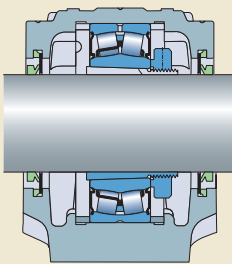
Table 2

SKF standard bearing housing variants

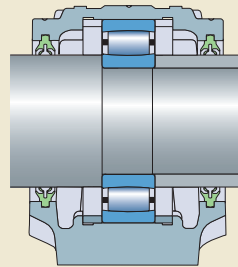
Designation Suffix	Description
A	Housing for a shaft end
B	Housing for a through shaft
F	Housing for a locating bearing arrangement
G	Housing for a bearing with a cylindrical bore on a stepped shaft
K7	Housing with a seat diameter to K7 tolerance class
L	Housing for non-locating bearing arrangement
/MS1	Two drilled holes in the base for attachment bolts
/MS2	Four drilled holes in the base for attachment bolts
SN	Housing with a drilled and tapped hole for a sensor
TURA	Housing prepared for oil lubrication, with labyrinth seals
TURT	Housing prepared for oil lubrication, with labyrinth seals
TURU	Housing prepared for oil lubrication, with labyrinth seals
V	Housing with a grease escape hole in the base

4

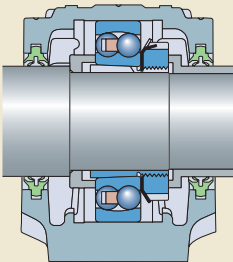
Fig. 2



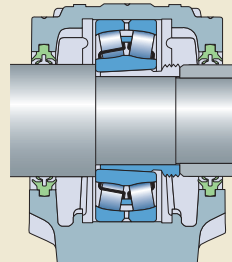
Bearing on an adapter sleeve on a plain shaft



Bearing on a cylindrical seat on a stepped shaft



Bearing on an adapter sleeve on a stepped shaft



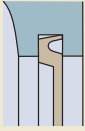
Bearing on a withdrawal sleeve on a stepped shaft

Standard sealing solutions for SKF bearing housings

Series designation	Description
Seals for metric series housings	
ASNH	End cover for SNL housings
ETS	End cover for large SNL housings
FS	Felt strip (split)
TS	Labyrinth seal for large SNL housings (solid)
TFL	Double-lip seal for flanged housings (solid)
TNF	Taconite heavy-duty seal with radial labyrinth for large SNL housings (solid)
TSD .. U	U-design labyrinth oil seal ¹⁾
TSN .. A	V-ring seals (solid)
TSN .. C	Felt ring seals (split)
TSN .. CB	Graphited felt ring seals (split)
TSN .. L	Four-lip seals (split)
TSN .. NC	Taconite heavy-duty seal with axial labyrinth (solid)
TSN .. ND	Taconite heavy-duty seal with radial labyrinth (solid)
TSN .. S	Labyrinth ring (solid)
TSN .. TURU	U-design labyrinth oil seal ¹⁾
Seals for inch series housings	
B-17024-	Nitrile rubber contact element for a PosiTrac Plus seal (solid)
EPR	End cover (plug)
LER	Labyrinth ring (solid)
LOR	PosiTrac seal: labyrinth ring with an O-ring inside the bore (solid)
TER	Taconite seal with an inboard felt seal and outboard contact seal (solid)
TER-V	Taconite seal with an inboard felt seal and outboard V-ring (solid)

¹⁾ Delivered as a complete unit only, i.e. modified housing with seals.

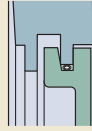
Fig. 3



ASNH



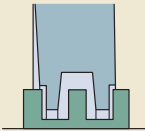
EPR



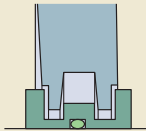
ETS



FS



LER



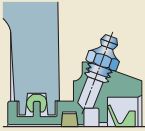
LOR



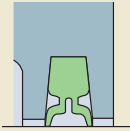
LOR + B-17024-



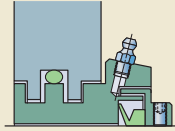
TER



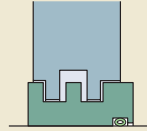
TER-V



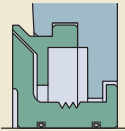
TFL



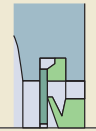
TNF



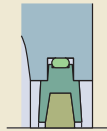
TS



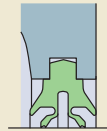
TSD..U



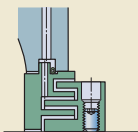
TSN..A



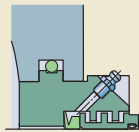
TSN..C



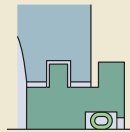
TSN..L



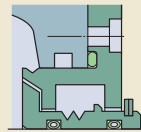
TSN..NC



TSN..ND



TSN..S



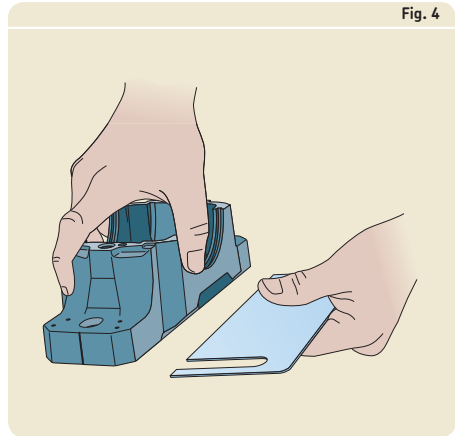
TSN..TURU

Preparations prior to mounting

Prior to mounting, do the following:

- Make sure that the work area is clean.
- Study any drawings or instructions to determine the correct order in which to assemble the various components.
- Make sure that all the necessary parts and tools are at hand.
- Check that the support surface of the housing is clean. The support surface should not be painted.
- Check that the support surface conforms to the requirements for flatness and rigidity. To prevent deformation to the housing bore, SKF recommends that the flatness of the surface is within IT7 tolerance grade (→ **Appendix C, page 385**). The surface should be finished to $R_a \leq 12,5 \mu\text{m}$.
- Before reusing a housing, clean the housing thoroughly and replace all wear parts, e.g. contact seals, O-rings or rubber cords.

Fig. 4



Using shims

The elevation of the centre height of plummer (pillow) block housings can be adjusted with shims. When using a shim, make sure that the shim covers the complete contact surface between the housing base and the support surface (→ fig. 4).

Bolts

If recommendations about the attachment bolts or nuts are not available, SKF recommends using the following to attach the housing to the support surface (→ **fig. 5**):

- hexagon head bolts in accordance with EN ISO 4014:2000
- hexagon socket head cap bolts in accordance with EN ISO 4762:1998
- hexagon nuts in accordance with EN ISO 4032:2000
- flat washers in accordance with EN ISO 7089

If the load acts vertically to the support surface, 8.8 class bolts or nuts can be used. If the load does not act vertically, 10.9 class bolts or nuts should be used.

Tighten all cap bolts and attachment bolts using the recommended torque values listed in **table 4**. Inch series housings use cap bolts from various classes. Tighten the cap bolts on these housings using the torque values listed in the mounting instructions supplied with the housings.

Fig. 5

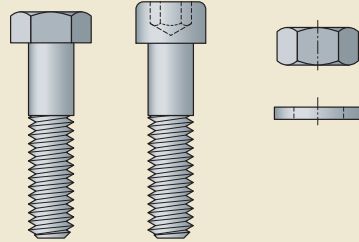


Table 4

Recommended tightening torque values for attachment bolts and cap bolts, class 8.8

Bolt size	Tightening torque		Cap bolts ¹⁾	
	Attachment bolts		Nm	ft.lbf
mm/inch	Nm	ft.lbf	Nm	ft.lbf
10	45	34	50	37
12	80	60	80	60
16	200	150	150	110
20	385	285	200	150
24	665	485	350	260
30	1 310	970	400	300
36	2 280	1 690	600	445
42	3 640	2 700	850	630
48	5 450	4 030	1 250	920
56	8 710	6 420	–	–
64	13 100	9 660	–	–
72	18 800	13 900	–	–
1/2	95	70	–	–
5/8	185	135	–	–
3/4	320	235	–	–
7/8	515	380	–	–
1	770	570	–	–
1 1/8	1 090	800	–	–
1 1/4	1 530	1 130	–	–
1 3/8	2 020	1 490	–	–
1 1/2	2 650	1 950	–	–

¹⁾ For inch series housings, the recommended tightening torque is supplied with the housing.

Using locating (stabilizing) rings

The width of the bearing seat in most SKF standard bearing housings is sufficiently wide to enable axial displacement “s” of the widest bearing that fits the housing (→ fig. 6). For locating bearing arrangements, which have to provide axial location of the shaft in both directions, locating rings must be used to locate the outer ring of the bearing in the housing seat (→ fig. 7). SKF locating rings are identified by the prefix FRB followed by the size (width/outside diameter) in millimetres uncoded, e.g. FRB 11.5/100 (→ fig. 8).

CARB toroidal roller bearings are an exception. These non-locating bearings cannot accommodate axial loads, but can accommodate axial displacement within the bearing. Therefore, the outer ring must be located axially in its seat by a locating ring on each side.

Typically, two locating rings are required for one housing. One ring should be placed on each side of the bearing. If only one locating ring is required, it should be inserted on the same side as the lock nut. When placing a locating ring in position, make sure that the open end of the locating ring is positioned upwards (→ fig. 12, page 134).

Very large SNL housings, starting from sizes 3076, 3168, 3264 and 4076 are available in two variants depending on the bearing position. The housing seat is machined to suit: Housings for the locating bearing position are identified by the designation suffix F and do not require locating rings. Housings for the non-locating bearing position are identified by the designation suffix L.

CAUTION: When mounting a CARB toroidal roller bearing, a locating housing (designation suffix F) must be used.

Fig. 6

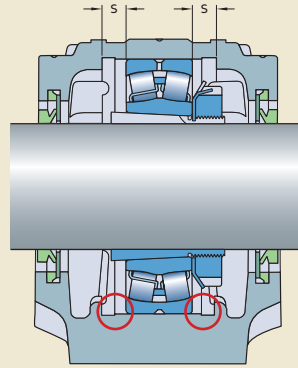


Fig. 7

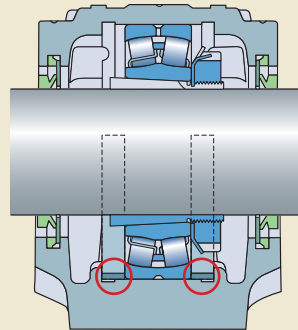
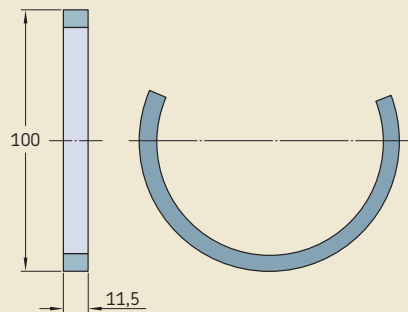


Fig. 8



FRB 11.5/100

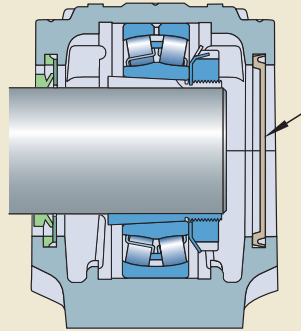
Using end covers

SKF bearing housings at the end of a shaft should be fitted with an end cover (plug). End covers typically fit into the seal groove (→ fig. 9).

Installing split or solid seals

Split plunger (pillow) block housings are available with either split or solid seals. Split seals are easy to mount: the seal halves fit into the seal grooves in the housing base and cap. Solid seals have to be slid onto the shaft. Be sure that the seal is oriented correctly, as many solid seals are not symmetrical.

Fig. 9



Mounting standard split plummer (pillow) block housings

When mounting plummer (pillow) block housings, carefully follow the guidelines provided under *Preparations prior to mounting* on **page 130** as well as the additional guidelines below:

NOTE: Seals suitable for plummer (pillow) block housings are typically supplied with mounting instructions.

1 Prepare the shaft:

- Mount any components that are on the shaft between the two bearing positions. If solid seals are used, this includes the inboard seals.
- Mount the bearings on each side of the shaft. For grease lubrication, completely fill the bearings with grease.
- If the shaft is stepped, mount distance rings, if necessary.

NOTE: Distance rings are not supplied with the housings.

- If solid seals are used, mount the outboard seals on each end of the shaft. If a housing is to be used at the end of the shaft, omit the seal. An end cover will be used in the housing instead.

2 Determine the position of the housings:

- If the housing is used for a stepped shaft and the housing bore has different diameters, the position is fixed by the housing bore diameters.
- If the housing has the same bore diameter on both sides, consider the position of the grease fitting in the cap. When relubricating self-aligning ball bearings and CARB toroidal roller bearings from the side, the housing must be positioned so that the grease fitting is on the opposite side of the lock nut.
- When a housing is located at the end of a shaft, the grease fitting on the cap must be positioned at the cover side.

Fig. 10

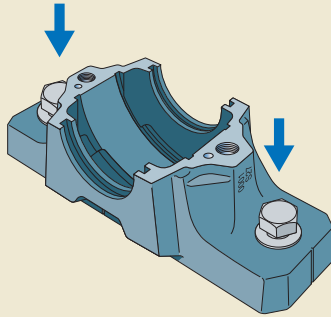


Fig. 11

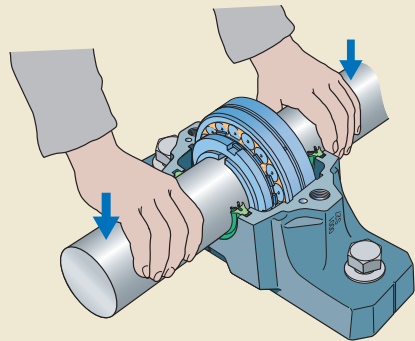
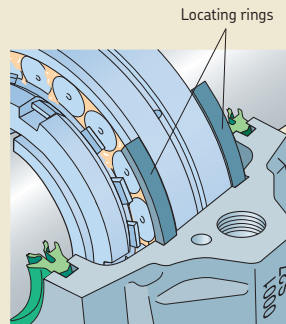


Fig. 12



- 3 Position the housing bases on the support surface. Fit the attachment bolts (→ **fig. 10**), but do not tighten them. If split seals are used, insert a seal half in each housing base groove, where applicable.
- 4 Place the prepared shaft in the housing base(s) (→ **fig. 11**). Be careful not to damage the already installed seals.
- 5 If required, put a locating ring on each side of the locating bearing (→ *Using locating (stabilizing) rings*, **page 132**). Make sure that the open end of the locating ring is positioned upwards (→ **fig. 12**).

NOTE: Non-locating CARB toroidal roller bearings always require a locating ring on both sides.

- 6 Carefully align the housing bases. Then lightly tighten the attachment bolts.

NOTE: SNL housings and many other SKF housings have vertical markings on the housing base ends and side faces, indicating the bearing seat centre (→ **fig. 13**).

- 7 Fill the housing bases with the recommended quantity of grease. SKF recommends filling the free space at both sides of the bearing seat up to
 - 40%, when relubricating from the side of the bearing.
 - 20%, when relubricating through the annular groove and the lubrication holes in the outer ring.

NOTE: Several housings have a marking indicating a 40% filling grade level (→ **fig. 14**).

- 8 If required, put the end cover into the seal groove of the housing base.
- 9 If split seals are used, insert the remaining seal halves in the seal grooves of the two housing caps (→ **fig. 15**). If applicable, fill the space between the inner seal lips with grease.

Fig. 13

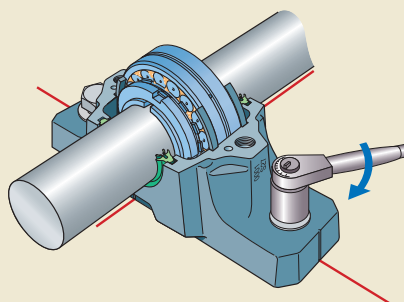


Fig. 14

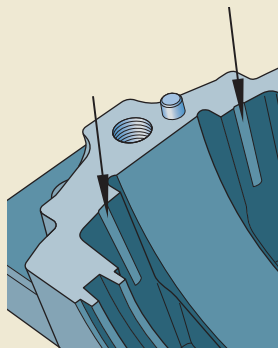
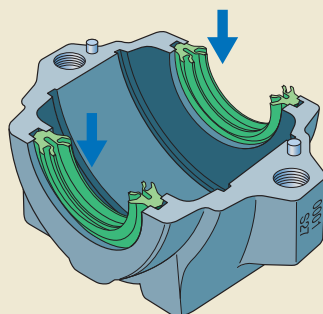


Fig. 15



Mounting bearing housings

- 10 Place a housing cap over each base (→ **fig. 16**) and tighten the cap bolts to the recommended tightening torque (→ **table 4** on **page 131**).

CAUTION: Caps and bases are not interchangeable. Make sure that the cap and base have the same serial number.

- 11 Check alignment again, and fully tighten the attachment bolts (→ **fig. 17**) using the recommended torque values listed in **table 4** on **page 131**.
- 12 If necessary, complete the seal assembly. This can include:
- For V-ring seals: coat the V-ring counterface with grease. Then push the V-ring into position.
 - For labyrinth rings: lengthen and insert the hollow silicone tube in the inboard groove of each labyrinth ring with a screwdriver while turning the shaft.
 - For grease purged seals: supply grease via the grease fitting in the seal cavity while turning the shaft.
- 13 SKF recommends re-tightening the cap and attachment bolts one or two days later to make sure the appropriate torque is maintained.

Fig. 16

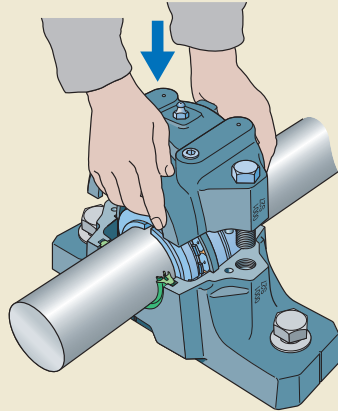
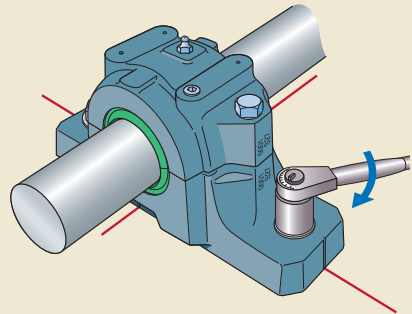


Fig. 17



Mounting SONL plummer (pillow) block housings

When mounting SONL plummer (pillow) block housings, carefully follow the guidelines provided under *Preparations prior to mounting* on **page 130** as well as the additional guidelines below:

NOTE: Seals suitable for plummer (pillow) block housings are typically supplied with mounting instructions.

- 1 Mount any components that are on the shaft between the two bearing positions.
- 2 Determine the position of the bearings or sleeves on the shaft and mark it.
- 3 (→ **fig. 18**) Slide the inner spacer sleeves with the labyrinth flange (a) together with the seal rings (b) and O-rings (c) on each side of the shaft and place the oil pick-up rings (d) in position on the spacer sleeves with the labyrinth flange.

NOTE: Don't ever mount the oil pick-up ring (d) for circulating oil lubrication systems!

- 4 Mount the bearings on the shaft or adapter sleeves (→ **fig. 19**).
- 5 Slide the outer spacer sleeves with the labyrinth flange on each side of the shaft and place the seal rings and O-rings in position on the spacer sleeves. If the housing is at the end of the shaft, omit the second seal and insert the end cover together with the two O-rings in the housing base.
- 6 Position the housing bases on the support surface. The side with the oil-collecting trough at the bearing seat must be positioned on the inner side of the bearing arrangement (→ **fig. 20**). Fit the attachment bolts, but do not tighten them.
- 7 Install the oil level gauge and the magnetic plug on each housing base, if an oil pick-up ring is used. Whenever possible, install the oil level gauge on the side opposite the oil pick-up ring so that the reading is not affected by eddies caused by the ring. If an oil-cooling cartridge is used, install it now, following the instructions supplied with the cartridge.

NOTE: To avoid oil leakage, apply an oil-resistant sealant on the threads of all

Fig. 18

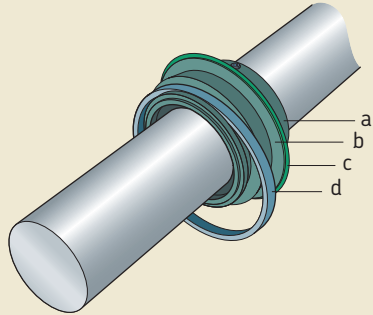


Fig. 19

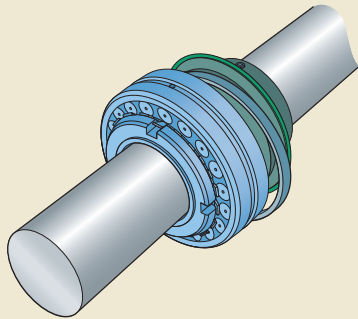
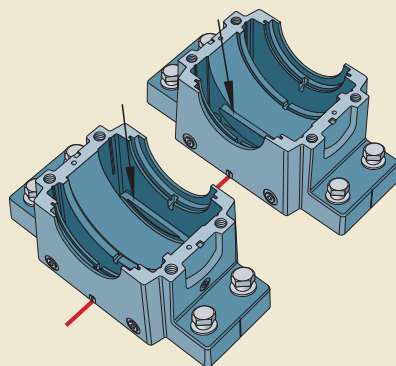


Fig. 20



Mounting bearing housings

attached components such as the oil level gauge and pipes.

- 8 Arrange the seals against the bearing. If an adapter sleeve is used, tighten the grub (set) screws in the sleeves that have the labyrinth flange. Recommended tightening torques:

- sizes 17 to 26 8 Nm (6 ft.lbf)
- sizes 28 to 32 18 Nm (13 ft.lbf)
- sizes 34 to 48 35 Nm (26 ft.lbf)

- 9 Place the shaft assembly in the two housing bases (→ fig. 21).

NOTE: Be sure the oil pick-up rings reach into the oil collecting troughs and hang loosely.

- 10 If required, put a locating ring on each side of the locating bearing (→ *Using locating (stabilizing) rings*, page 132). Make sure that the open end of the locating ring is positioned upwards (→ fig. 22).

NOTE: Non-locating CARB toroidal roller bearings always require a locating ring on both sides.

- 11 Carefully align the housing bases. Then lightly tighten the attachment bolts.

NOTE: SONL housings have vertical markings on the housing base ends and side

Fig. 22

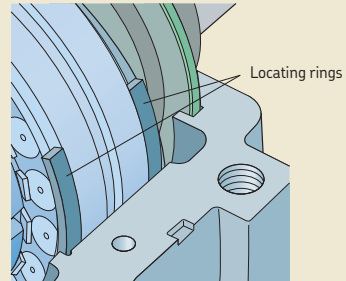


Fig. 23

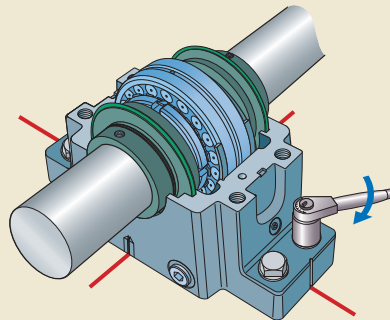


Fig. 21

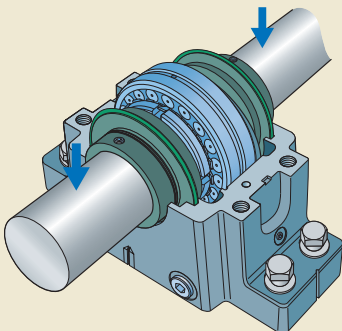
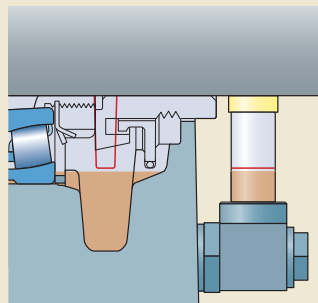


Fig. 24



faces, indicating the bearing seat centre (→ fig. 23).

- 12** If a circulating oil lubrication system will be used, connect the oil outlet pipes to the housing.

CAUTION: The outlet pipe(s) must drain properly or the housing may overflow.

- 13** If oil pick-up rings are used, fill the housings with oil up to the indicated maximum level. The oil level gauge and cast markings inside the housing base indicate the maximum level (→ fig. 24).

CAUTION: Oil level may drop during operation. Do not overfill the housing or leakage may result.

- 14** Cover the mating surfaces of the housing with an oil-resistant sealant.
- 15** Place a housing cap over each base (→ fig. 25) and tighten the cap bolts (to join the cap and base) using the recommended torque values listed in **table 4** on **page 131**. The cap and base of one housing are not interchangeable with those of other housings. Make sure that they bear the same serial number.

NOTE: Place the housing cap on the base carefully to prevent damage to the O-rings.

- 16** If a circulating oil lubrication system will be used, connect the inlet pipe to the housing cap.
- 17** Check alignment again, and fully tighten the attachment bolts in the housing base (→ fig. 26) using the recommended torque values listed in **table 4** on **page 131**.
- 18** SKF recommends re-tightening the cap and attachment bolts one or two days later to make sure the appropriate torque is maintained.

Fig. 25

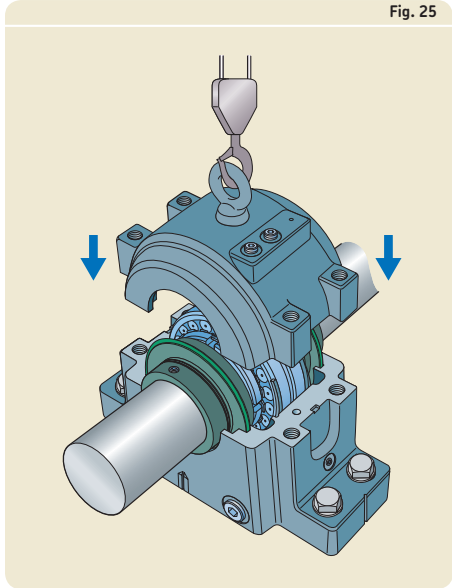
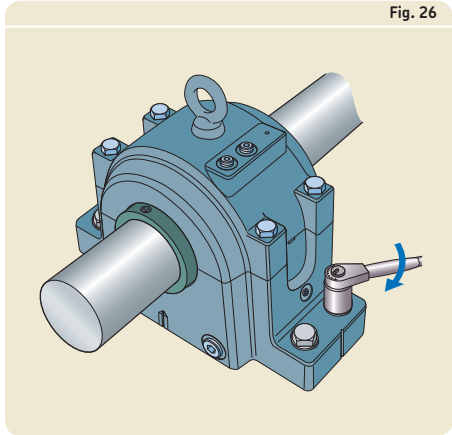
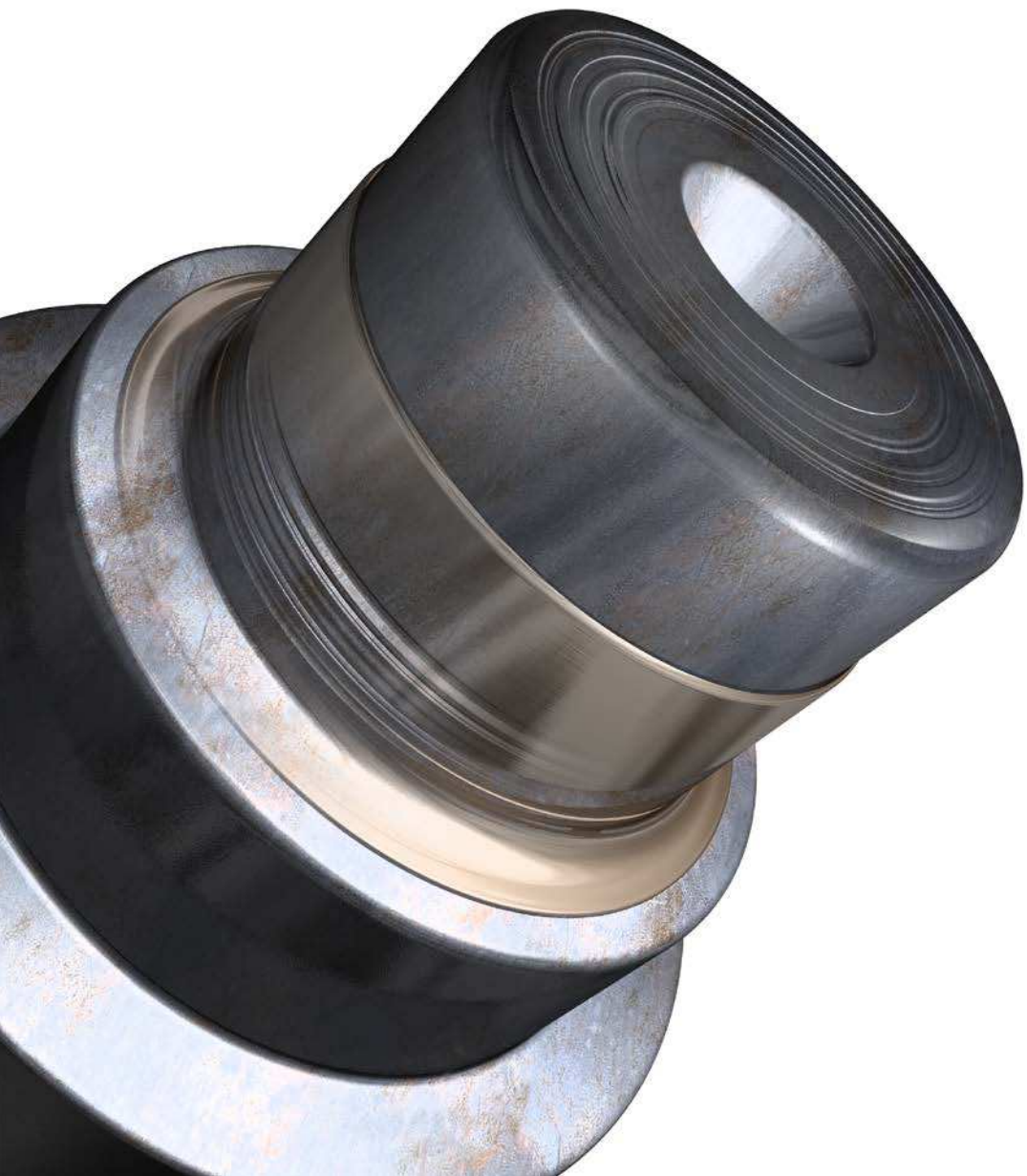


Fig. 26





Installing seals

General	142
What to remember	142
SKF Bearing fitting tool kit	146
Preparations prior to installation	146
Installing a radial shaft seal into a housing	146
Installing seals that have an auxiliary lip . . .	149
Installing a solid all-rubber seal.	149
Installing a radial shaft seal over a shaft	150
Replacing a radial shaft seal	151
Repairing a worn shaft with an SKF wear sleeve	152
Installing an SKF SPEEDI-SLEEVE	152
Installing a large diameter wear sleeve . . .	152
Installing a large, split all-rubber seal . . .	154
Installing sealing washers	156
Installing a V-ring seal	157

General

To perform as intended, seals must be installed properly. This can most easily be done if you have installation experience and a clean work environment and also use suitable tools. The seal counterface, the area where the seal lips contact the shaft, should meet the specifications for surface roughness and roundness, and should be clean. If the counterface shows any signs of wear, repair it. This can be done easily with an SKF SPEEDI-SLEEVE or a large diameter wear sleeve (LDSLVL). If it can't be easily repaired, replace the shaft.

Because radial shaft seals are so common, and play such an important role in protecting the bearings, lubricant and other critical components from contaminants, this chapter is limited to such seals unless specified otherwise.

What to remember

SKF seals are available in many types, designs and variants. The most common radial shaft seals are listed below:

- metal-cased radial shaft seals with a garter spring
- metal-cased radial shaft seals without a garter spring
- radial shaft seals with a rubber outside diameter and a garter spring
- radial shaft seals with a rubber outside diameter, without a garter spring

When replacing a seal, be sure that the replacement seal matches the original with regard to the following:

- seal type and design (→ **tables 1a** and **1b**)
- material of the seal lip (→ **table 2, page 145**)

CAUTION: A simple ordering error can result in sudden seal failure, e.g. a nitrile rubber seal might be installed instead of a much more temperature-resistant fluoro rubber seal, although the design is otherwise identical.

For additional information about SKF mounting and installation tools, visit www.mapro.skf.com.

The SKF Reliability Maintenance Institute (RMI) offers a comprehensive range of training courses (→ *Training*, starting on **page 326**). Contact your local SKF representative for additional information, or visit www.skf.com/services.


















The SKF program SKF Sealfinder, available online at www.skf.com, contains seal data from approximately 80 different seal manufacturers or distributors, for a quick cross reference.

WARNING:

At temperatures above 300 °C (570 °F) all fluoro elastomers and PTFE compounds give off dangerous fumes. If there is contact with your skin or if the vapours are inhaled, seek medical advice immediately.

Table 1a

Radial shaft seals for general industrial applications

Seal type without an auxiliary lip		with an auxiliary lip		Description
CRS1		CRSA1		Metal-cased seal with a garter spring
CRSH1		CRSHA1		Reinforced metal-cased seal with a garter spring
CRW1		CRWA1		Metal-cased seal with an SKF WAVE seal lip and a garter spring
CRWH1		CRWH1A1		Reinforced metal-cased seal with an SKF WAVE seal lip and a garter spring
CRW5		CRWA5		Metal-cased seal with a pressure profile SKF WAVE seal lip and a garter spring
HMS5		HMSA10		Rubber outside diameter seal with a garter spring
HMS4		HMSA7		Rubber outside diameter seal with a garter spring
SL SLX SLS DL		SLA DLA		Metal-cased seal with a PTFE seal lip(s)
YSL YNSLE YSL				All-PTFE seal with an O-ring(s)

Radial shaft seals for heavy industrial applications























Seal type without an auxiliary lip		with an auxiliary lip		Description
HDL		HDLA		
HDS1 HDS2		HDSA1 HDSA2		Metal-cased seal with a garter spring in an SKF Springlock groove (HDS2 and HDSA2 also have an SKF Springcover)
		HDSB1 HDSB2		Metal-cased seal with a garter spring in an SKF Springlock groove (HDSB2 also has an SKF Springcover)
		HDSC1 HDSC2		Metal-cased seal with a garter spring in an SKF Springlock groove (HDSC2 also has an SKF Springcover)
HDS3				Metal-cased seal with a garter spring in an SKF Springlock groove with an SKF Springcover and adjustable spacer lugs
HDS4				Rubber outside diameter seal with a garter spring and spacer lugs moulded into the seal body
HDS6				Rubber outside diameter seal without a garter spring, with spacer lugs moulded into the seal body
HDS7				Metal-cased seal without a garter spring
HDSD1 HDSD2				Metal-cased seal with two seal lips facing opposite directions, with garter springs
HDSE1 HDSE2				Metal-cased seal with two seal lips facing the same direction, with garter springs
HS4 HS5				Solid all-rubber seal with a garter spring in an SKF Springlock groove (HS5 also has an SKF Springcover)

Table 1b cont.

Radial shaft seals for heavy industrial applications

Seal type without an auxiliary lip		with an auxiliary lip		Description
HS6 HS7 HS8				Split all-rubber seal with a garter spring in an SKF Springlock groove (HS7 and HS8 also have an SKF Springcover)
HSF1 HSF2 HSF3		HSF4		Split fabric-reinforced seal with a garter spring
HSF5 HSF6 HSF7 HSF9		HSF8		Solid fabric-reinforced seal with a garter spring
SBF				Metal-inserted seal with a garter spring
R01-P R01-R		R02-P R02-R		Rubber outside diameter seal with a garter spring
R01-AF R01-AS				Rubber outside diameter seal with a garter spring

5

Table 2

SKF seal lip material variants

Designation suffix	Seal lip material	Designation example
R, RG	Acrylonitrile-butadiene rubber (NBR)	CR 15X35X7 CRW1 R
H	Hydrogenated acrylonitrile-butadiene rubber (HNBR)	CR 420X470X20 HDS3 H
D	Carboxylic-acrylonitrile-butadiene rubber (XNBR) (SKF Duralip)	CR 240X280X16 HDS2 D
V	Fluoro rubber (FKM) (SKF Duralife) ¹⁾	CR 640X680X20 HDLV
T	Polytetrafluoroethylene (PTFE)	CR 70X90X10 RD10 T

¹⁾ Important safety information about fluoro elastomers is supplied on page 142.

SKF Bearing fitting tool kit

The SKF Bearing fitting tool kit can be used to install radial shaft seals with an outside diameter up to 120 mm. The kit consists of:

- 3 impact sleeves, for even force distribution, marked with the letters A, B or C
- 36 impact rings, marked with the letter for the corresponding impact sleeve and the inside and outside diameter of the ring, e.g. B 25/52
- 1 double-sided dead-blow hammer

Preparations prior to installation

To obtain a reliable seal and achieve the best results, do the following:

- Make sure that the dimensions of the selected seal match those of the shaft diameter and housing bore.
- Make sure that the selected seal can withstand the media as well as the operating temperature and speed.
- Check the seal for any damage, e.g. dents, scores or cuts. Never use a damaged seal.
- Carefully clean the seal if it has become dirty. Use warm soapy water (not above 30 °C (85 °F)) and allow the seal to dry at room temperature.
- Chamfer and blend the housing bore corner to prevent damage to the outside surface of the seal.
- The housing bore and counterface on the shaft should meet the requirements given by SKF with regard to dimensional and form accuracy, roughness and hardness.
- All shaft edges over which the seal lip must pass should be chamfered or rounded.
- Lightly coat the seal with the lubricant that will be used for the application. PTFE seal lips should not be pre-lubricated unless they are used in applications that run dry.

Installing a radial shaft seal into a housing

When installing a seal into a housing bore, the installation force should be applied as close as possible to the outside diameter of the seal. Therefore, SKF recommends using a mandrel in

conjunction with a mechanical or hydraulic press (or hammer).

CAUTION: During installation, make sure the orientation of the seal lip is correct (→ fig. 1). When the primary function of the seal is to prevent contamination, the seal lip should face outward toward the contaminants. When the primary function is to retain lubricant, the seal lip should face inward toward the lubricant.

The following are suggested installation methods that depend on the application and the location of the seal:

- seal back face to seat against a shoulder or a retaining ring – use a mandrel (→ fig. 2).
- at a certain distance within an opening – use a mandrel with a stop to position the seal properly (→ fig. 3).
- flush with the wall of the housing bore – use the SKF Bearing fitting tool kit (→ fig. 4). Otherwise, cover the seal with a wood or plastic board and tap the seal into place with a hammer (→ fig. 5).

If a suitable installation tool is not available for large seals, SKF recommends using a wooden block (→ fig. 6) or a metal fitting disc. When using alternative tools, work evenly around the circumference of the seal to prevent the seal from tilting or skewing. If the seal is to be recessed behind the housing wall, a piece of wood should be used (→ fig. 7).

Fig. 1

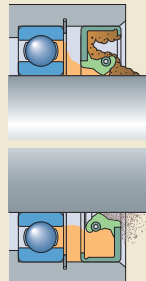


Fig. 2

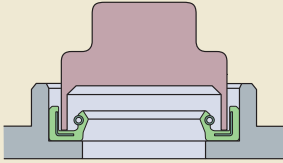


Fig. 5

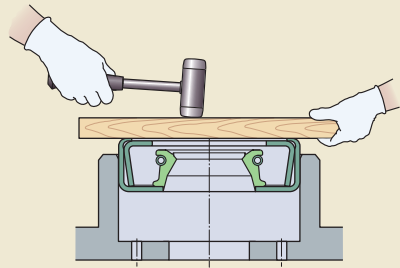


Fig. 3

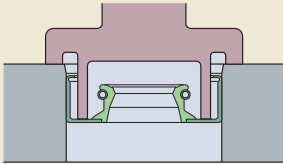


Fig. 6

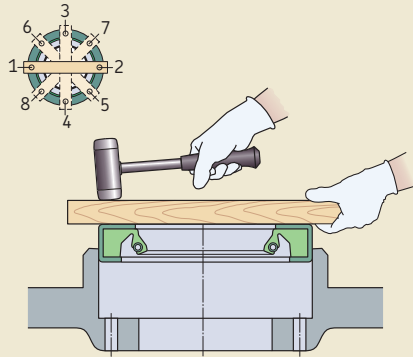


Fig. 4

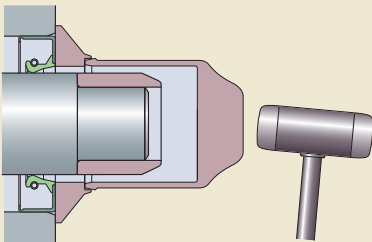
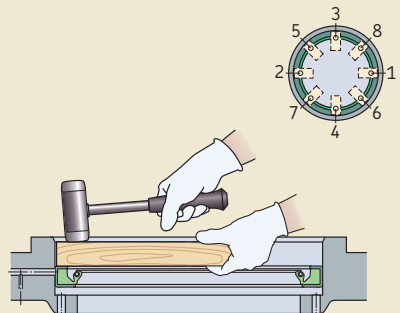
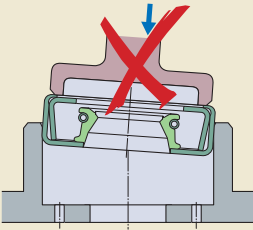


Fig. 7



Installing seals

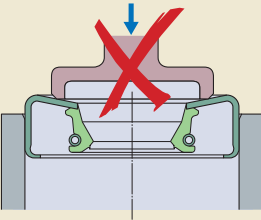
Fig. 8



When installing a seal into a housing bore:

- Make sure that the seal and installation tool are not in an inclined position (→ **fig. 8**). They should be perpendicular to the housing.
- Make sure that the outside diameter of the tool extends to the outside diameter of the seal, or there is a risk that the seal will bend or distort (→ **fig. 9**).
- Never use a drift punch (→ **fig. 10**).
- Always tap the installation tool gently with a hammer.
- Never hit the seal directly with any type of hammer (→ **fig. 11**).

Fig. 9



CAUTION: Use sealants sparingly (to prevent contact with the seal lip, counterface and bearing).

Fig. 10

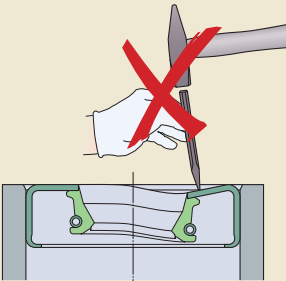
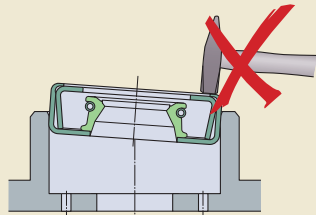


Fig. 11



Installing seals that have an auxiliary lip

When installing double-lip seals or seals that have a contacting auxiliary lip, fill the gap between the primary and auxiliary lip with an appropriate grease (→ **fig. 12**). This does not apply to silicone rubber seals or seals with hydrodynamic aids.

Installing a solid all-rubber seal

All-rubber seals can be installed by hand; no special installation tools are required. However, after installation, the seal must be axially clamped in the housing bore by a retaining cover (→ **fig. 13**).

Fig. 12

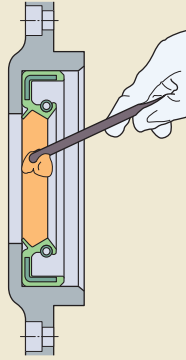
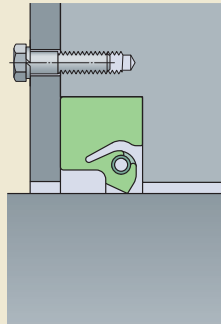


Fig. 13



Installing a radial shaft seal over a shaft

When installing a seal over a shaft, SKF recommends the following:

- Cover all grooves, keyways, cross holes, splines, threads, and any other sharp edges with a thin-walled (< 0,5 mm) protective cap (→ **fig. 14**).
- Use a sleeve when the shoulder of a stepped shaft is not chamfered or rounded (→ **fig. 15**).

The outside surface of protective caps and sleeves should be coated with the same lubricant as the seal and counterface. The outside surface and lead-in chamfer of the installation tool should be free of any burrs or sharp edges.

Radial shaft seals made of PTFE should always be installed using a protective cap or sleeve.

If, after the seals have been installed, the housing or machine is to be painted, the seals must be protected from the paint. Discs cut from cardboard (→ **fig. 16**) can be used.

Fig. 14

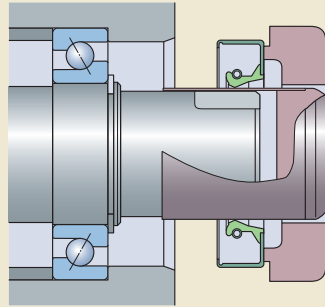


Fig. 15

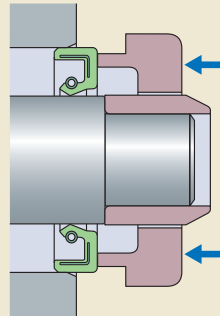


Fig. 16

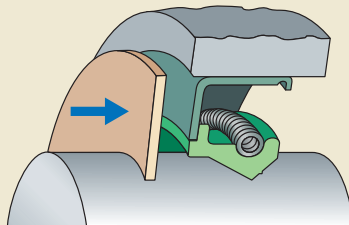
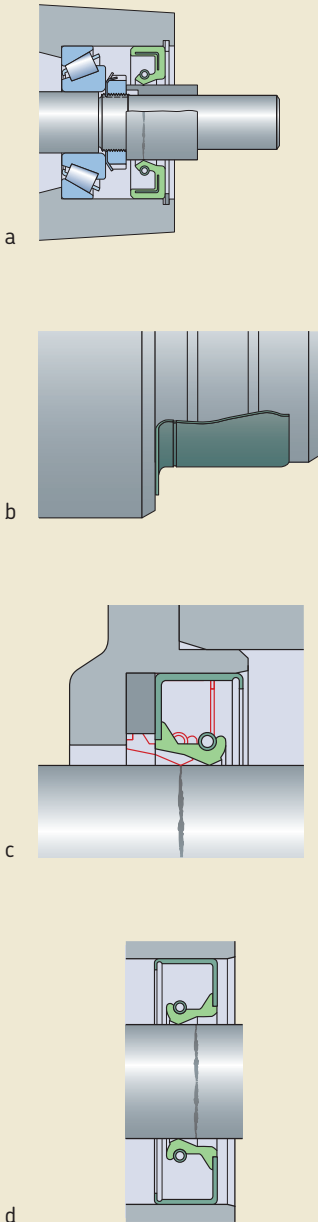


Fig. 17



Replacing a radial shaft seal

CAUTION: Once a radial shaft seal has been removed from an application, it should never be reused.

If the seal counterface shows any signs of wear or damage, it must be repaired. There are several ways to do this (→ **fig. 17**):

- Rework the shaft counterface; this requires shaft removal.
- Replace the ring that served as a counterface (**a**).
- Install an SKF SPEEDI-SLEEVE (for shaft diameters ≤ 203 mm) (**b**), or a large diameter wear sleeve (LDSL) (for shaft diameters > 203 mm).
- Install a spacer ring in the housing bore between the housing shoulder and the seal (**c**).
- Press the new seal to a different depth in the housing bore (**d**).

When applicable, the seal lip should always be displaced toward the side of the medium to be sealed (**c**).

When choosing a replacement seal, the design and material should correspond to the original. In case of doubt, a higher quality seal should be used to make sure it can withstand the operating conditions.

If a seal of the same design is not available in the same width as the original, a somewhat narrower seal could be used. Or, if the depth of the housing bore allows, a somewhat wider seal could be chosen as a replacement.

Repairing a worn shaft with an SKF wear sleeve

Installing an SKF SPEEDI-SLEEVE

SKF SPEEDI-SLEEVE wear sleeves provide a quick, easy and inexpensive way to repair the seal wear track on a shaft. These sleeves, which eliminate the need to disassemble a machine so that the shaft can be sent out for repair, can significantly reduce repair and downtime costs. Another advantage of SKF SPEEDI-SLEEVE wear sleeves is that the material is only 0,28 mm thick.

Although installation is simple, it should be done carefully to achieve the best results (→ fig. 18).

- 1 Clean the seal counterface on the shaft. Remove any burrs or rough spots (a) and make sure that the sleeve will not be installed over keyways, cross holes, splines or similar.
- 2 Measure the diameter where the sleeve will be positioned on an unworn portion of the shaft. Measure in three positions and average the readings (to make sure the shaft is within recommended specifications). If the mean diameter is within the range for a given sleeve size, there is sufficient press fit built into the sleeve to keep it from sliding or spinning without using an adhesive.
- 3 Determine where the sleeve must be positioned to cover the seal wear track. Measure to the exact point, or mark directly on the surface. The sleeve must be placed over the worn area, not just bottomed or left flush with the end of the shaft.
- 4 Shallow wear grooves do not require filling. Optionally, a light layer of a non-hardening sealant can be applied to the inside diameter surface of the sleeve. Clean away sealant that migrates to the shaft or sleeve outside diameter surface.
- 5 If the shaft is deeply scored, fill the groove with a powdered metal epoxy type filler. Install the sleeve before the filler hardens, allowing the sleeve to wipe off any excess filler. Clean away any remaining filler from the sleeve outside diameter surface.

CAUTION: Never use heat to install an SKF SPEEDI-SLEEVE!

- 6 The flange can most often be left intact, but in applications where the flange will interfere with other components, it should be removed. If it needs to be removed, cut it perpendicular to the outside diameter in one location. The flange end of the sleeve goes on the shaft first. Then, place the installation tool over the sleeve (b).
- 7 Gently tap the centre of the installation tool until the sleeve covers the worn surface. If the installation tool is too short, a length of pipe or tubing with a squared-off, burr-free end (c) can be used. Be sure that the inside diameter of the pipe is the same as that of the installation tool. Take care not to scratch the precision-ground sleeve outside diameter.
- 8 An SKF SPEEDI-SLEEVE should always be installed so that the outside edge of the sleeve is seated on the full shaft diameter to prevent the sharp edge damaging the seal during installation.
- 9 If the flange was cut for removal, use a pair of long-nose pliers to grasp the flange away from the seal surface (d) and twist it into a coil, being careful not to lift the end of the sleeve off the shaft or it will leave a jagged edge. Flange removal must be done with care to avoid damage to the sleeve outside diameter.
- 10 After the sleeve is installed, check again for burrs that could damage the seal.
- 11 Lubricate the sleeve with the system media before installing the seal.
- 12 Proceed with the seal installation.
- 13 Start mounting the new seal following the instructions mentioned above or re-mount the end cover provided with a new seal (e).

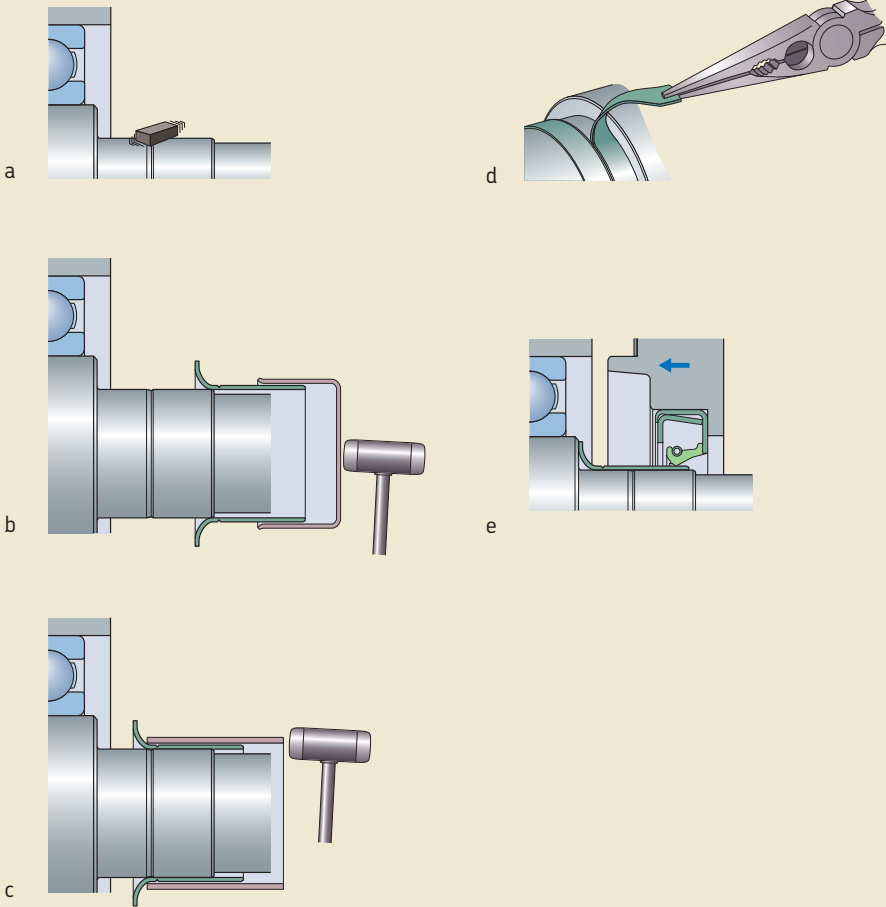
Installing a large diameter wear sleeve

SKF large diameter wear sleeves (LDSL) are designed for a heated slip-fit installation. The sleeve must be heated uniformly to approximately 180 °C (355 °F) prior to installation on the shaft, using suitable equipment such as an SKF induction heater.

CAUTION: Do not heat the sleeve to temperatures above 200 °C (390 °F).

The sleeve should be installed immediately after heating since it cools rapidly and could seize on

Fig. 18



5

the shaft before the correct position is achieved. If the sleeve requires repositioning, be careful not to damage the outside diameter or lead-in chamfer.

Installing a large, split all-rubber seal

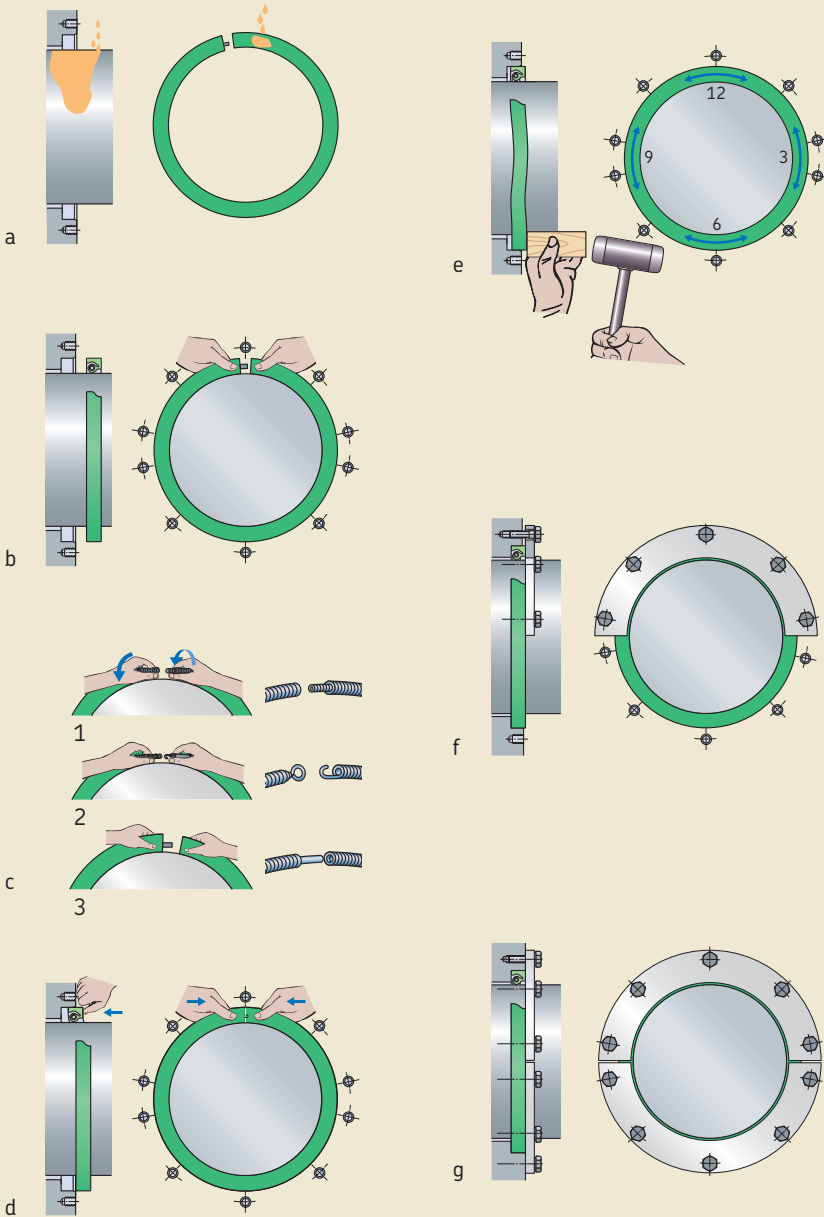
When installing a split all-rubber seal in the HS6, HS7 and HS8 series or a split fabric-reinforced seal in the HSF1, HSF2, HSF3 and HSF4 series, follow these instructions (→ **fig. 19**).

- 1 Where appropriate, insert the spring in the SKF Springlock groove and position the spring connection so that it is displaced with regard to the seal joint.
- 2 Apply a light coat of lubricant to the seal lips and counterface (**a**). Use the same lubricant that will be used to lubricate the application.
- 3 Check that the seal lip is facing the correct direction (**b**).
- 4 Join the ends of the garter spring:
 - For springs with threaded type connectors (**c1**), applicable for seals in the HSF1, HSF2, HSF3 and HSF4 series, wind the spring ends together. Insert one end into the other and screw into position.
 - For springs with hook-and-eye connectors (**c2**), applicable for seals in the HS6 series and most seals in the HS8 series, draw the ends of the spring together and insert the hook into the eye. Do not over-stretch the spring as this might impair seal performance.
 - For springs with control wire connectors (**c3**), applicable for seals in the HS7 series, draw the ends of the seal together. Then, insert the control wire into the other end of the spring. Do not over-stretch the spring as this might impair seal performance.
- 5 Position the seal joint on the shaft so that it is in the 12 o'clock position and push the seal at its joint into the housing bore (**d**).
- 6 Push the rest of the seal into position starting at the 3 and 9 o'clock positions (**e**), finishing simultaneously at the 6 and 12 o'clock positions. For shaft diameters of 1 200 mm and above, it may be preferable to fix the seal in the 12, 3, 6 and 9 o'clock positions before locating the remaining sections of the seal.

CAUTION: Never insert only one end of the seal and wrap the remaining part of the seal around the shaft. The seal will stretch, making installation into the housing bore difficult or even impossible.

- 7 Push the seal into the housing bore using a small block of wood, until it makes contact with the housing shoulder (**e**).
- 8 Check the seal, particularly at the joint.
- 9 Install the cover plate (**f** and **g**). Tighten the attachment bolts evenly, until the end cover abuts the housing face.

Fig. 19



Installing sealing washers

Sealing washers – with or without a flocked washer (→ **fig. 20a**) – should always be arranged as shown in **fig. 21a** so that the pumping effect of the discs is away from the bearing. If spacing washers (→ **fig. 20b**) are intended to facilitate relubrication, one spacing washer must be installed adjacent to the inner ring and the other adjacent to the outer ring (→ **fig. 21b**).

- 1 Fill the free space between the two washers with a water-repellent and rust inhibiting grease, e.g. SKF LGMT 2.
- 2 Lightly coat the bore and outside washer surfaces with grease.
- 3 Place the washer set in the starting position. Be sure that the side face of the housing washer will abut the bearing outer ring (→ **fig. 21b**).
- 4 Press the washer set into the housing bore and onto the shaft simultaneously, using a dolly or similar tool that abuts both washers (→ **fig. 22**). Make sure the washers are not skewed.
- 5 Where several sets of washers are to be installed adjacent to each other, install the first set before installing the next.

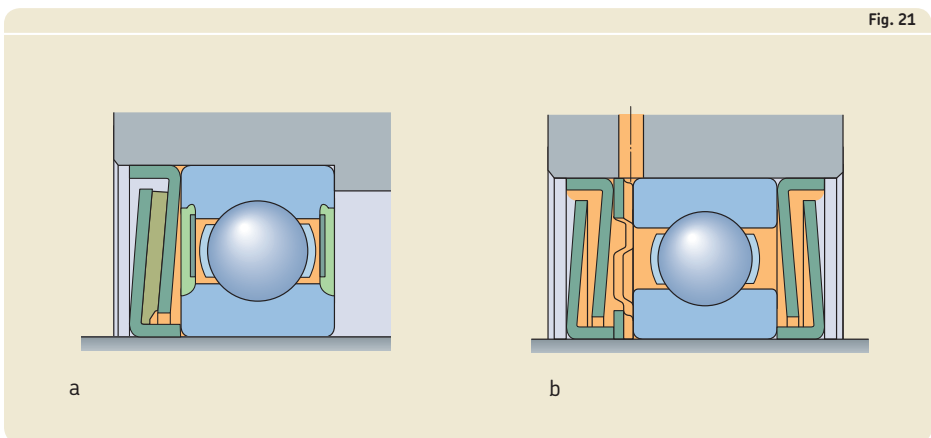
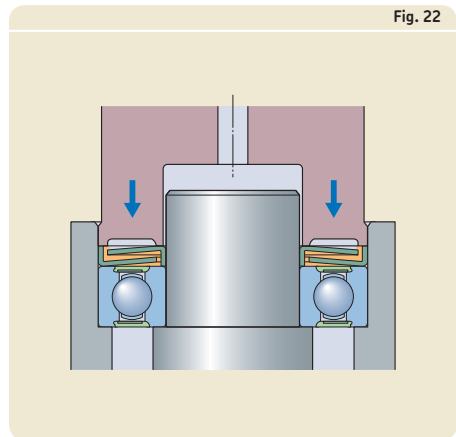
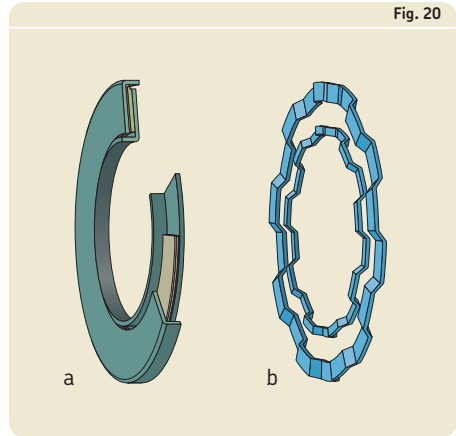
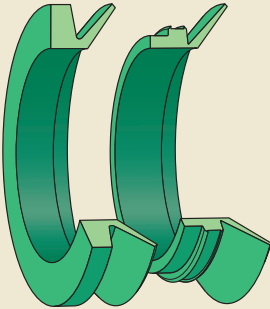


Fig. 23



Installing a V-ring seal

V-rings seals (→ **fig. 23**) are elastic and can be stretched over other components, making installation simple and easy (→ **fig. 24**). In cases where many V-rings of the same size are to be installed, simple installation tools (→ **fig. 25**) can be made to push the seal to a predetermined depth.

When installing a V-ring seal, make sure it fits uniformly around the shaft and the fitted width, from the counterface to the backside of the V-ring, is within specified tolerances.

Fig. 24

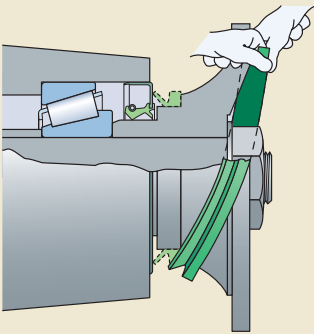
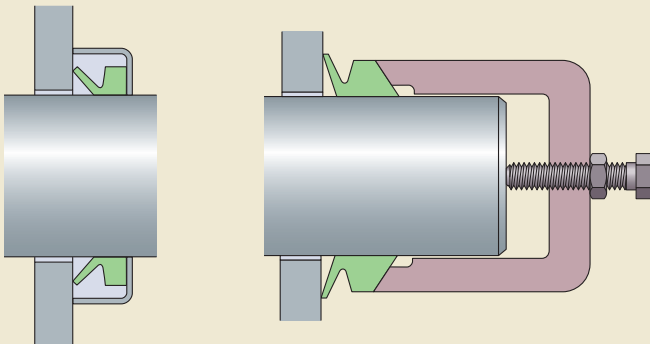


Fig. 25





SKF

SKF Shaft Alignment Tool TESA 60



Alignment

Introduction	160	Belt alignment	176
Machine installation and alignment	161	Types of belt misalignment	176
Foundation quality	161	Belt alignment tolerances	176
Alignment targets	161	Belt alignment methods	176
Soft foot	162	Traditional belt alignment methods	176
Types of soft foot	162	Laser belt alignment methods	176
Checking for soft foot	162		
Shimming	163		
Machinery shims	163		
SKF Vibracon SM elements	164		
Customized rigid steel chocks	164		
Epoxy resin	165		
Bolt tightening	166		
Tightening torque and assembly preload	166		
Tightening tools	166		
Shaft alignment	167		
Types of misalignment	167		
Measuring conventions	167		
Stationary and movable machines	167		
Alignment parameters	168		
Measuring positions	168		
Shaft alignment tolerances	169		
Shaft alignment methods	170		
Traditional shaft alignment methods	170		
Dial indicator methods	170		
Laser shaft alignment methods	172		
The alignment process	173		
Offset drive alignment	175		
Offset drive alignment tolerances	175		
Offset drive alignment methods	175		
Laser offset drive alignment methods	175		

Introduction

Alignment of drives and driven machinery is an important activity during initial installation and maintenance. Machine alignment is crucial in preventing premature bearing damage and subsequent damage to other components. The cost to align machines properly is small, relative to escalating maintenance costs, should a critical piece of equipment fail.

Alignment is required for:

- shafts
- offset drives, e.g. cardan shafts
- drive belts (pulleys)
- rolls and cylinders, e.g. in paper machines

The principal procedures employed for shaft, offset drive and belt alignments are presented in this chapter.

The benefits of accurate alignment include:

- extended bearing service life
- extended seal service life
- extended coupling service life
- extended maintenance intervals
- improved energy efficiency
- lower vibration and stress levels

For additional information about alignment of shafts, offset drives and belts, as well as information about roll and cylinder alignment, visit www.apitudexchange.com or www.skf.com.

The SKF Reliability Maintenance Institute (RMI) offers a comprehensive range of training courses in alignment techniques (→ *Training*, starting on **page 326**). Contact your local SKF representative for additional information, or visit www.skf.com/services.

Shaft and belt alignment tools as well as machinery shims are available from SKF Maintenance Products (→ **Appendix K, page 419**). For additional information, visit www.mapro.skf.com.

SKF has experienced alignment services teams. For additional information, visit www.skf.com/services.

Machine installation and alignment

Proper alignment of drives and driven machinery depends largely on the quality of the machine installation. An optimal installation contributes to a quick and easy alignment process with precision results.

To achieve optimal installation, several aspects deserve consideration:

- foundation quality
- alignment targets
- soft foot
- shimming
- bolt tightening

Foundation quality

The key element when installing a machine is to provide a foundation that supports and maintains alignment between components under dynamic conditions. Whether it is a new machine installation or an existing machine being re-aligned, SKF recommends the following:

- 1 Inspect the foundation for cracks, deterioration and damaged bolt holes, and repair if necessary.
- 2 Remove existing shims and chocks. If they are not damaged, inspect them for rust and clean them, if necessary, before reuse.
- 3 Remove any rust, paint or oil from the foundation mounting surface.
- 4 Replace any existing attachment bolts if they are rusted or have thread damage.
- 5 Check the flatness of the foundation with a laser. The flatness should be within IT7 tolerance grade.

NOTE: All repair work should be completed before starting any alignment procedures!

Alignment targets

Machine components heat up and expand during operation (→ **fig. 1**). This is referred to as thermal expansion and depends on the material and temperature of the machine.

Generally, machine designers calculate thermal expansion and specify alignment parameters to compensate for it. These parameters

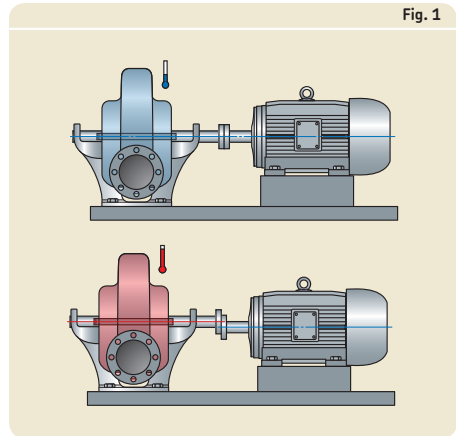


Fig. 1

are provided typically as coupling offset values or adjustment values at the machine feet.

In addition to any instructions given by the machine designers, SKF recommends aligning machines when they are stable in temperature relative to the foundation, casings and ambient temperature. Before starting with alignment, the temperature difference between the machine casings and their foundations should not exceed 10 to 15%. Also, make sure that the alignment targets take the real temperature into consideration (as they are often based on an assumed ambient temperature).

Alignment

Soft foot

Soft foot (→ **fig. 2**) refers to a condition where a machine does not rest solidly on its foundation. Soft foot is typically caused by:

- damaged foundations, especially those that are cracked
- distorted or damaged machine base frames that rest on only part of their surface
- faulty shimming

Types of soft foot

There are two types of soft foot (→ **table 1**)

- parallel soft foot
- angular soft foot

A soft foot condition makes vertical alignment impossible, since the machine can move during the precision alignment stage. Tightening the attachment bolts to compensate for soft foot can distort the machine housing, causing improper alignment that can result in premature bearing failure.

Both parallel and angular soft foot can be resolved using SKF Vibracon SM elements. For additional information, refer to *Shimming*, starting on **page 163**.

Checking for soft foot

Checking for soft foot is best achieved by using feeler gauges and registering four values per foot. With this method, the values and the type of soft foot can be determined with good precision.

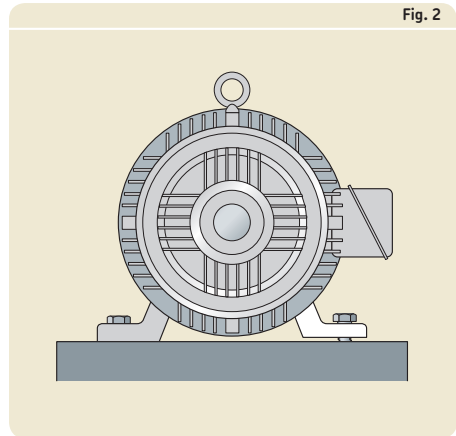


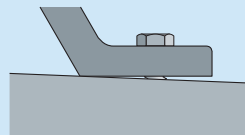
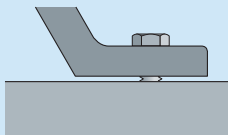
Fig. 2

To determine if there is a gross soft foot problem, SKF recommends using laser methods.

For additional information, refer to the relevant section *Shaft alignment*, starting on **page 167** or *Belt alignment*, starting on **page 176**.

Table 1

Types of soft foot



Description **Parallel soft foot**
The machine foot is parallel to the machine base frame but does not rest on it. Also known as "short foot".

Correction Remove the gap by adding shims.

Use SKF Vibracon SM elements to prepare the mounting surface for the machine (→ *SKF Vibracon SM elements*, **page 164**).

Description **Angular soft foot**
Only part of the machine foot rests on the machine base frame. Also known as "angled foot".

Correction Adjust the angle or add a customized chock (wedge).

Use SKF Vibracon SM elements to prepare the mounting surface for the machine (→ *SKF Vibracon SM elements*, **page 164**).

Shimming

Shimming is the method used to fill the gap between the support surface and the machine base frame. Shimming devices include:

- machinery shims
- adjustable steel levellers, e.g. SKF Vibracon SM elements (→ **fig. 3**)
- customized rigid steel chocks
- epoxy resin

The shimming process varies depending on the type of shim selected. Some shims are designed to establish the proper mounting plane for new installations or repair applications. Others are used to correct soft foot in preparation for the realignment of an existing machine.

Machinery shims

Machinery shims are thin alignment elements used to accurately adjust the overall height of a machine or to compensate for parallel soft foot. Shims are fitted between the machine feet and the support surface (→ **fig. 4**).

SKF recommends using shims made of stainless sheet steel with sufficient strength and the ability to withstand corrosion from several media. Shims made from inappropriate materials such as copper or brass are generally too soft and will plastically deform. This causes looseness and leads to possible alignment problems over time.

SKF supplies machinery shims in the TMAS series in five different sizes, each with ten different thicknesses (**tables 2a and 2b, page 164**) for attachment bolts up to 52 mm in diameter. These pre-cut single slot shims are made of high-quality stainless sheet steel and are manufactured to close tolerances for accurate alignment. The shims are supplied in sets of ten, each marked individually with its thickness.

CAUTION: Where possible, use only one shim. Do not stack more than three shims. Doing so increases the number of mating surfaces, influencing the recommended bolt elongation. For additional information about bolting, refer to *Bolt tightening* on **page 166**.

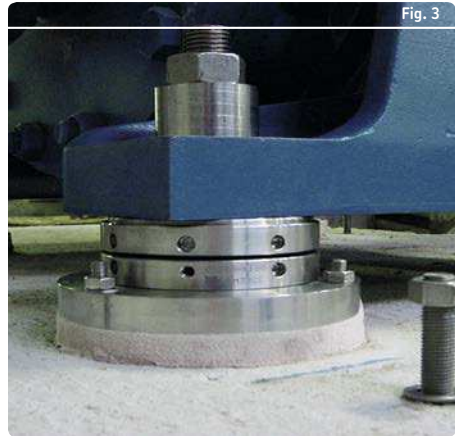


Fig. 3

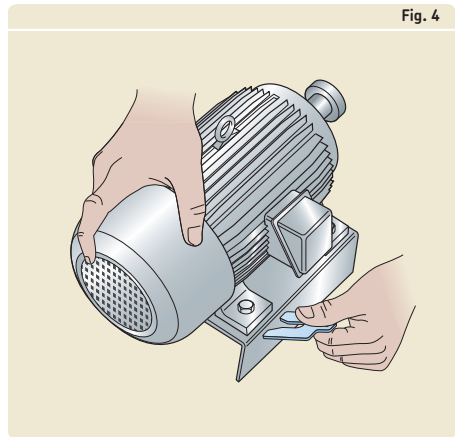
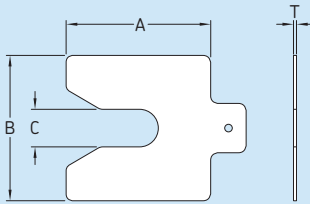


Fig. 4

Table 2a

SKF Machinery shims TMAS series



Designation ^{1) 2)}	Dimensions			T ²⁾
	A	B	C	
–	mm			
TMAS 50-xxx	50	50	13	xxx
TMAS 75-xxx	75	75	21	xxx
TMAS 100-xxx	100	100	32	xxx
TMAS 125-xxx	125	125	45	xxx
TMAS 200-xxx	200	200	55	xxx

¹⁾ 10 shims per set

²⁾ xxx refers to the shim thickness (→ table 2b)

Table 2b

Shim thickness

Designation	Dimension T	Tolerances
–	mm	
005	0,05	± 0,010
010	0,10	± 0,020
020	0,20	± 0,025
025	0,25	± 0,025
040	0,40	± 0,030
050	0,50	± 0,030
070	0,70	± 0,040
100	1,00	± 0,040
200	2,00	± 0,045
300	3,00	± 0,150

SKF Vibracon SM elements

SKF Vibracon SM elements are ready-to-mount, universal height adjustable steel units that provide a good mounting plane, especially in cases where soft foot may be a problem.

Standard SKF Vibracon SM elements (→ fig. 5) are manufactured in two designs for attachment bolts from 12 to 65 mm diameter:

- SKF Vibracon original (a)
- SKF Vibracon low profile (b)

CAUTION: SKF Vibracon SM elements are not designed for lifting machinery! In these cases, SKF recommends using low height hydraulic cylinders or jacks.

Detailed instructions for installing SKF Vibracon SM elements are supplied with the elements.

Customized rigid steel chocks

Customized rigid steel chocks (slotted elements) should only be used in repair applications and under conditions where:

- the adjustment height is too low for SKF Vibracon SM elements
- the adjustment height is too high for machinery shims
- angular soft foot is present

The design and size of customized chocks (→ fig. 6) depends on the application conditions, e.g. machine weight and foundation type.

Epoxy resin

Epoxy resin is used mainly to align propulsion machinery. Epoxy resin is typically cast between the foundation and the machine base frame (→ **fig. 7**) and is suitable for height adjustments ranging from 15 to 100 mm.

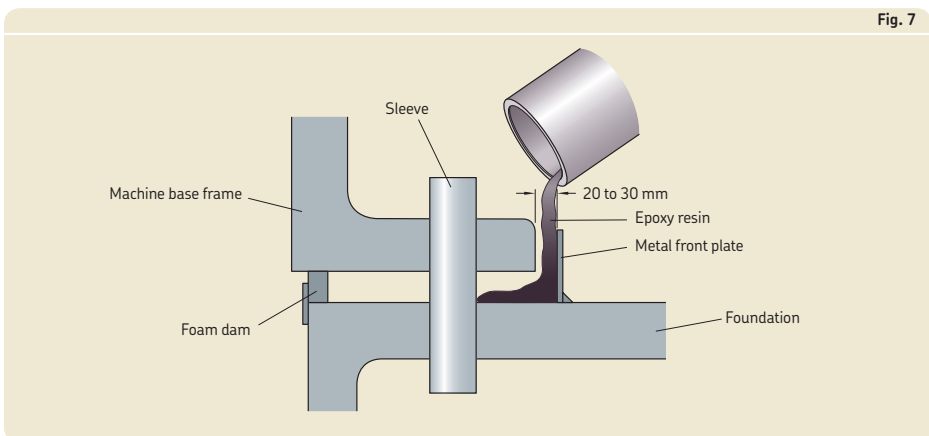
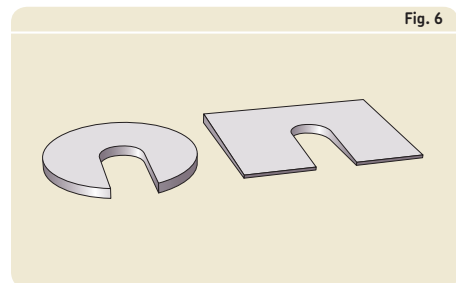
Appropriate resins have a relatively short curing period, good compression resistance and good resistance to extrusion and thermal shocks. SKF recommends using Epocast 36, a two-part epoxy, as base material.

For additional information about epoxy resins, contact the SKF application engineering service.

Casting epoxy resin

Clean the support surface area of all paint and dirt. Score the support surface, creating undercuts. Drilling shallow holes at various angles in the support surface achieves the same result. This attaches the epoxy to the foundation.

Set the sleeve in position through the foot of the machine and into the foundation. Build a plywood or foam dam around the foot of the machine, using caulk to seal between the dam and the support surface. Apply parting agent to the sleeve, machine base frame and the dam. Fill the dam with resin until it is just above the bottom of the foot.



Bolt tightening

Applying the correct torque value to a bolt during machine installation is extremely important. Improper torque values can lead to machinery movement during operation. This can cause misalignment of the shaft, which will eventually lead to premature damage to bearings and other components.

Generally, the machine designer does not determine the torque values. If these are not available from the machine owner, contact the SKF application engineering service.

Tightening torque and assembly preload

Attachment bolts should be tightened to a maximum bolt tension of 75% of the yield strength.

Tightening tools

All bolts and nuts should be tightened with an accurate torque wrench (in at least two stages) or a hydraulic bolt tensioner. For large bolts, SKF recommends using HYDROCAM hydraulic bolt tensioners (→ **fig. 8**), whenever possible. These tensioners enable bolts to be installed accurately without the need of a torque wrench. The tensioners also provide uniform assembly preload or uniform bolt elongation.

CAUTION: Tightening bolts with manual tools is inaccurate and does not provide reproducible results.

HYDROCAM hydraulic bolt tensioners

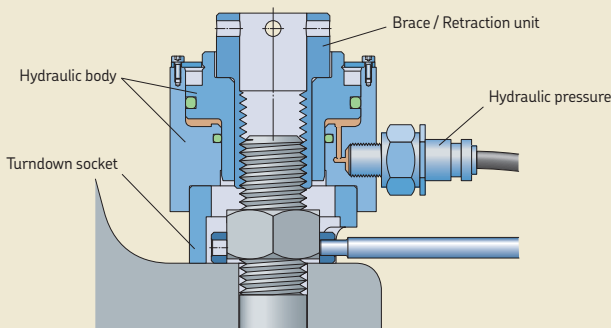
HYDROCAM hydraulic bolt tensioners are suitable for tightening bolts that have an end protruding above the tightening nut. Cold extension is applied to the bolt by means of an annular hydraulic body placed around it. The bolt is subjected to an axial traction load only.

The stress-free nut is then turned down with very little effort and does not transmit any torque to the bolt. When the fluid pressure is released in the tensioner, the major part of the hydraulic load on the tensioner is transferred into the nut, and tightening is completed.

For optimum accuracy, SKF recommends performing traction of the bolt and turning-down of the nut twice.

For additional information about HYDROCAM hydraulic bolt tensioners, contact the SKF application engineering service.

Fig. 8



Shaft alignment

All shafts, straight or offset, rotate about an axis called the rotational centre. In any power transmission application, the most efficient energy transfer occurs when two connected shafts are collinear, i.e. when the rotational centres of the shafts form a single straight line under normal operating conditions. Any deviation from this collinear state is referred to as misalignment.

The benefits of properly aligned shafts include:

- minimized induced bearing loads that result in longest bearing service life
- reduced wear on belts, pulleys, couplings and seals that result in extended maintenance intervals
- reduced friction losses, noise and vibration levels that result in improved energy efficiency
- reduced shaft bending that results in lower vibration and stress levels

Types of misalignment

There are two main types of shaft misalignment (→ fig. 9):

- offset (parallel) misalignment (a)
- angular misalignment (b)

In practice, both types of misalignment often exist simultaneously.

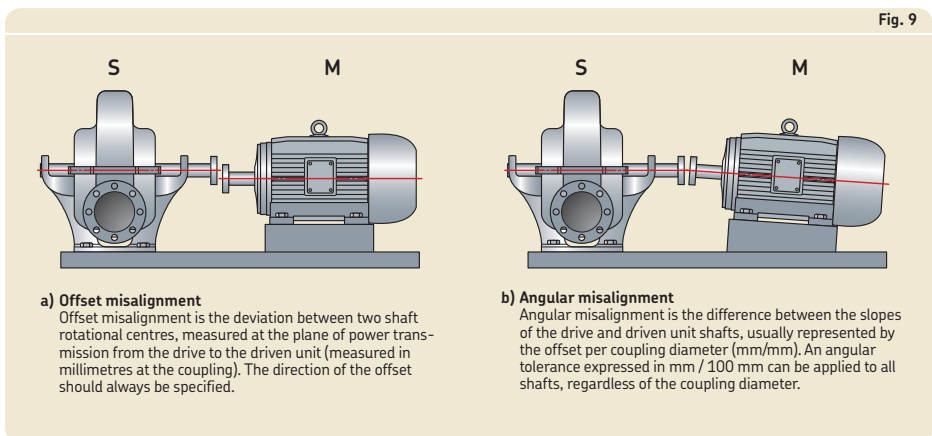
Measuring conventions

Stationary and movable machines

When aligning two machines, one is designated the stationary machine (S) and the other, the movable machine (M) (→ fig. 9). In most cases, the stationary machine is the driven unit. Adjustments are then made to the movable machine, typically a motor.

Sometimes, it is necessary to move both machines. For example, when the movable machine is either base- or bolt-bound, the stationary machine is moved slightly to enable precision adjustments of the movable machine.

6



Alignment

Alignment parameters

Misalignment is measured in two planes
(→ **fig. 10**):

- horizontal (side-to-side, along the x-axis)
- vertical (up and down, along the y-axis)

Each alignment plane has offset and angular components, so there are actually four alignment parameters to be measured and corrected:

- horizontal offset
- horizontal angularity
- vertical offset
- vertical angularity

Measuring positions

To define the various measuring positions during the alignment process, the analogy of a clock, as viewed facing the stationary machine (S) from behind the movable machine (M), is used (→ **fig. 11**). The position with the measuring units standing upright is defined as the 12 o'clock position, while 90° left and right are defined as the 9 and 3 o'clock positions respectively. The 6 o'clock position is opposite the 12 o'clock position (not shown).

As shown in **fig. 12**, measurements taken in the vertical plane, i.e. in the 12 or 6 o'clock position, are used to determine the vertical misalignment (**a**). Vertical misalignment is any misalignment when viewed from the side that is corrected by making height adjustments at the front and rear feet of the movable machine.

Fig. 10

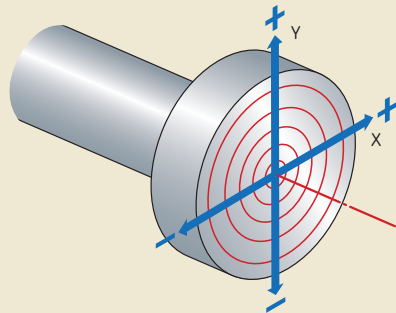


Fig. 11

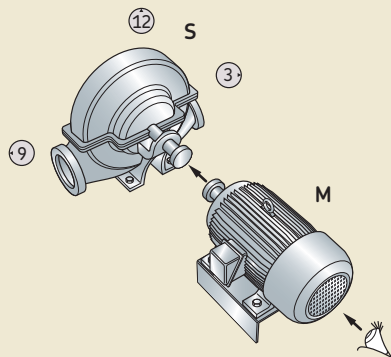
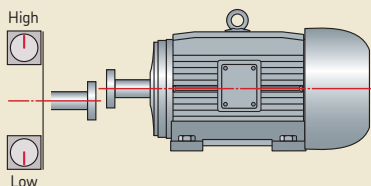
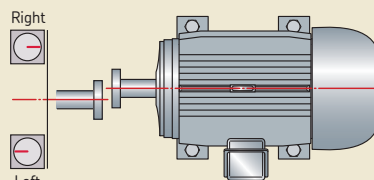


Fig. 12



a) Vertical misalignment



b) Horizontal misalignment

Measurements taken in the horizontal plane, i.e. in the 9 or 3 o'clock position, are used to determine the horizontal misalignment (b). Horizontal misalignment is any misalignment when viewed from the top that is corrected by sliding the movable machine sideways.

functions can be used to determine whether the target is dependent on a specific component.

NOTE: Accurate shaft alignment generally becomes more critical as speeds increase.

Shaft alignment tolerances

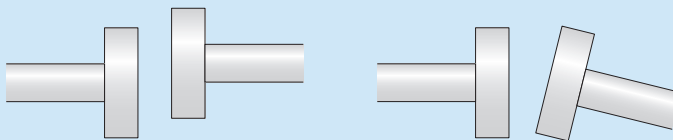
Shaft alignment tolerances are more commonly based on the rotational speed of the shaft than on the shaft diameter or specifications from the coupling manufacturer.

The machine designer is responsible for specifying the required alignment accuracy. However, if no specifications are available, the tolerances provided in **table 3** are commonly accepted. These tolerances are not related specifically to bearing type, machine size, driven speed or equipment type and should be used as a guideline only.

To compensate for thermal expansion, equipment manufacturers may publish thermal offset values that take the thermal growth during initial alignment into consideration. They will also take other factors into consideration for the alignment target. For example, for the horizontal alignment of a shaft in a gearbox, the gearbox arrangement and the various component

Table 3

Guidelines for shaft alignment tolerances



Rotational speed		Tolerances ¹⁾		Angular misalignment	
over	incl.	Offset misalignment	Acceptable	Excellent	Acceptable
r/min		mm		mm / 100 mm	
–	1 000	0,07	0,13	0,06	0,10
1 000	2 000	0,05	0,10	0,05	0,08
2 000	3 000	0,03	0,07	0,04	0,07
3 000	4 000	0,02	0,05	0,03	0,06
4 000	6 000	< 0,02	0,03	< 0,03	0,05

¹⁾ Tolerances vary depending on the bearing type, machine size and other design factors.

Alignment

Shaft alignment methods

There are various methods for aligning the shafts of two machines. Some of the principal shaft alignment methods are compared in **table 4** and described on **pages 170 to 173**.

SKF recommends using laser technology whenever possible.

NOTE: During alignment, measurements can be taken at the shaft end or at the half coupling rim. For the sake of simplicity, only the half coupling rim is mentioned in the following procedures. For information about alignment parameters and measuring positions, refer to *Measuring conventions*, starting on **page 167**.

Traditional shaft alignment methods

Traditional alignment methods are quick but often inaccurate. With these methods, mechanical tools such as straightedges, tape measures, wire, string, feeler gauges, spirit levels and calibrated cones are used.

Dial indicator methods

Dial indicators are used for two fundamental alignment methods (→ **fig. 13**):

- reverse rim method (**a**)
- rim-face method (**b**)

The reverse rim method is preferred because it is a “true” shaft alignment method. With this

method, two dial indicators are used to take measurements on both half coupling rims to determine the shaft offset between the stationary and movable machines.

With the rim-face method, one set of measurements is taken on the rim of the half coupling to determine the shaft offset. The other set of measurements is taken on the face of the half coupling to determine the shaft angularity.

CAUTION: Be careful not to miss a full revolution of the dial!

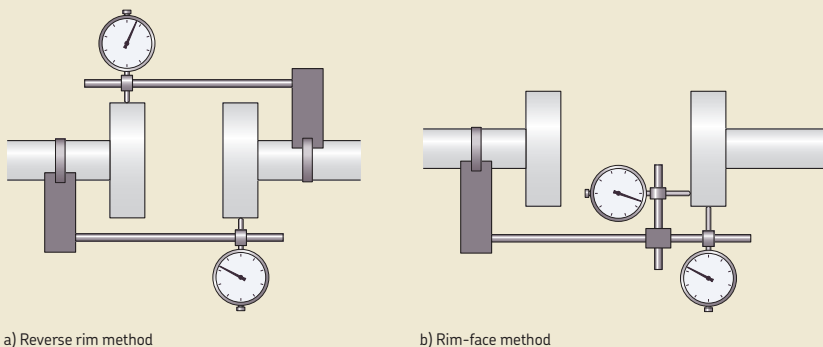


Fig. 13

Table 4

Shaft alignment methods				
Type	Method	Usage	Advantages	Disadvantages
Traditional	Straightedge	Rough alignment	Simple equipment	Inaccurate
			Direct readings	Readings rely on naked eye approximation and the accuracy of the half coupling face
Dial indicator	Reverse rim	Precision alignment, when laser equipment is not available	Relatively quick	Several repetitions are required
			Good accuracy	Requires specialized skills
	Rim-face	Checking shaft runout	Alignment is performed with all coupling elements in place	Time-consuming
			Offset and angularity measurements can be taken at the same time	Adjustment calculations are required
Rim-face	Precision alignment, when laser equipment is not available	Good accuracy	Requires specialized skills	
		Suitable for large couplings and where space is limited	Time-consuming	
Laser	Single laser	Precision alignment	Adjustment calculations are required	Requires specialized skills
			Accurate in angular measurement over short distances	Time-consuming
	Twin laser, e.g. using SKF Shaft alignment tools	Precision alignment for large and small shafts and for measuring distances of up to 10 m	Values automatically calculated by the equipment	Adjustment calculations are required
			Excellent accuracy	Method susceptible to backlash when moving the uncoupled machines
Twin laser, e.g. using SKF Shaft alignment tools	Precision alignment for large and small shafts and for measuring distances of up to 10 m	Specialist operators are not required	Re-measuring is required after each move, as the reference is lost	
		Displays real time alignment values and updated corrections as the machine is adjusted	The closer the distance between the measuring units, the less accurate the angular alignment measurement becomes	
Twin laser, e.g. using SKF Shaft alignment tools	Precision alignment for large and small shafts and for measuring distances of up to 10 m	Precision alignment for large and small shafts and for measuring distances of up to 10 m	Facilitates alignment over long distances	

Alignment

Laser shaft alignment methods

Laser alignment equipment makes shaft alignment faster and more accurate than any other method.

There are two types of laser systems used for alignment:

- single laser system
- twin laser system

The single laser system has a single laser beam and electronic detector with a single or double target. The twin laser system features a laser emitter and detector unit, and is based on the reverse rim dial indicator method.

Equipment featuring the twin laser system, such as SKF Shaft alignment tools (→ **fig. 14**), is strongly recommended.

CAUTION: Do not allow welding activities near laser alignment equipment or on the machine where the laser is attached. This can damage the laser diodes and electronics.

Twin laser method using SKF Shaft alignment tools

Checking alignment using SKF Shaft alignment tools is very simple and easily done. The process typically consists of:

- securing the measuring units to the shaft
- connecting the display unit
- measuring distances A, B and C (→ **fig. 15**) and entering the values in the display unit
- setting the measuring units



Fig. 15

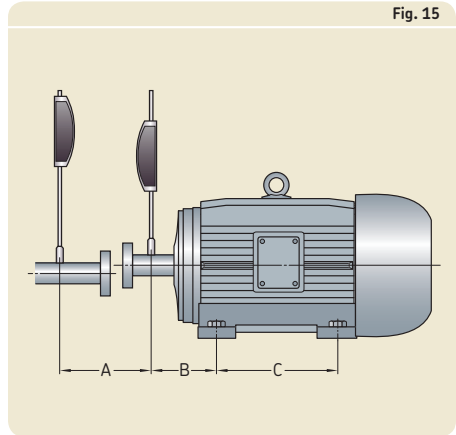
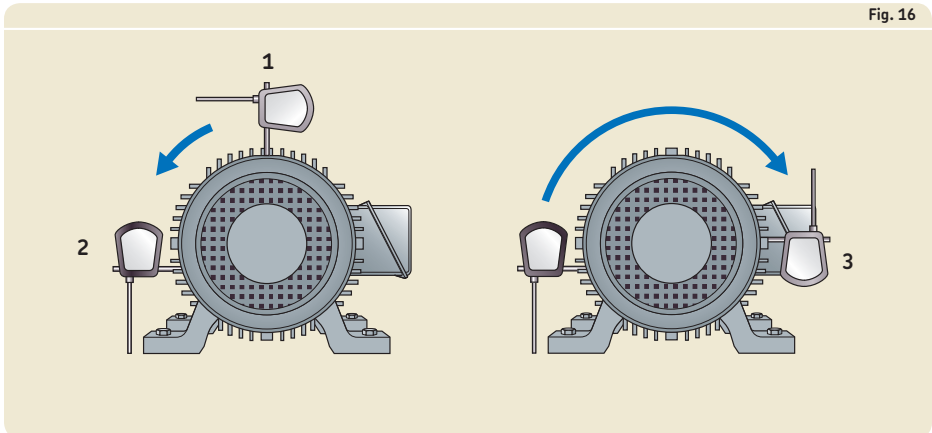


Fig. 16



- determining the machine feet adjustment by taking measurements with the laser beams in three different positions 1, 2 and 3 (→ fig. 16)
- using shims to make the necessary adjustments

Detailed instructions for use of SKF Shaft alignment tools are supplied with the equipment.

CAUTION: Readings from laser systems are affected by variables such as heat, light and vibration. To confirm the alignment, SKF recommends taking the measurements again, using the above steps.

The alignment process

The alignment process is very important. SKF recommends a multi-stage process (→ fig. 17) designed to secure the quality of the end result.

1. Preparation

Preparation is an important stage in the alignment process as it enables the alignment activities to be carried out smoothly. The problem definition, initial scope of work, conditional instructions, and task responsibilities should be clearly defined.

The result of the preparation stage is that all known information is stated clearly on a job card, and all tools and materials required for the inspection activities are available at the site.

2. Inspection

The goal of the inspection is to capture all data that describes the “as-is” condition of the machine. Examples of typical inspection activities include:

- Inspect the support surface and machine base frame.
- Measure soft foot.
- Measure the runout of both shafts.
- Establish which unit is stationary and which unit is movable.
- Select the alignment measurement method and prepare the measuring equipment.

For additional information about these activities, refer to *Machine installation and alignment*, starting on **page 161**.

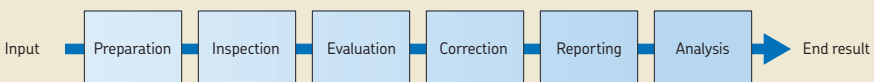
3. Evaluation

Compare the “as-is” condition with the “desired” condition of the machine and have the responsible persons decide on the appropriate actions on the measured deviations.

NOTE: Some deviations will not be corrected immediately after the evaluation stage. It is important to retain the information for these findings so that it can be used to initiate corrective action in the future. An additional risk assessment can be done to justify any delay in the corrective action.

The result of the evaluation stage is a clear decision on each finding, authorized by the responsible persons, about what corrective actions should be taken and the reason behind each decision. Each task is defined, and all tools and materials required for the alignment are available at the site.

Fig. 17



WARNING

To minimize the chance of serious injuries, prior to making any corrections, perform required lockout/tagout procedures.

4. Correction

Make initial corrections to minimize misalignment and improve the accuracy of the precision alignment measurements.

During rough alignment, the objective is to get the machines' shaft centrelines aligned sufficiently to enable a precision alignment measurement. There are no rules for how accurate the rough alignment measurement should be. In general, about 1 mm vertical and horizontal offset and about 0,1 mm / 100 mm vertical and horizontal angularity are considered "rough". To meet these requirements, one of the traditional alignment methods can be used (→ *Traditional shaft alignment methods*, page 170).

To achieve the required precision for shaft alignment, SKF recommends using a laser alignment system (→ *Laser shaft alignment methods*, starting on page 172). Where laser equipment is not available, dial indicators can be used.

NOTE: Test running the machine is an important part of alignment correction. A final measurement should be taken after the test run to make sure that no further corrections are necessary. A conformance check is strongly recommended.

SKF recommends checking the shaft alignment of newly installed equipment after three to six months of operation. This is due to "settling" of the support surface(s), and/or chocks/shims. In general, shaft alignment should be checked annually.

5. Reporting

Information gathered during the correction stage is usually not in a useable format. Therefore, a reporting stage is necessary.

The purpose of the reporting stage is to develop a clear, unambiguous document contain-

ing all the relevant data (in a suitable format) necessary to make further analyses. The time it took to complete the alignment and the resources used, as well as any deviations from standard procedures should be included.

6. Analysis

In the final stage of the alignment process, the comparison between the "as-is" condition and the "desired" condition of the machine is analyzed. The machine history (former reports and specifications) as well as the machine benchmarks (or other comparable data) can be used to draw conclusions about the root cause of any deviations.

The analysis is an opportunity to identify additional improvements and perform a cost benefit analysis for the future.

Offset drive alignment

In an offset drive, power is transferred from the drive to the driven unit by an offset, intermediate shaft. Often referred to as a cardan shaft, an offset drive typically has a universal joint at each end of the shaft.

The most common cardan shaft arrangement is the Z-configuration (→ **fig. 18**), typically used in the paper industry.

Why offset drives need to be aligned precisely

It is a common misconception that offset drives can tolerate a large alignment error and therefore do not need to be precision aligned. On the contrary, poorly aligned offset drives can lead to increased vibration levels, energy loss, premature wear and even complete failure through shearing.

To compensate for these undesirable results, offset drives require equal deflection angles in the joints and precision alignment of the drive and driven shafts.

Offset drive alignment tolerances

The accuracy of a laser offset drive alignment procedure is dependent on the half coupling face of the stationary machine, i.e. the rectangularity between the face and the rotational centre. Typically, an angular misalignment within 0,50 mm / 1 000 mm is acceptable. This is achievable in most circumstances provided there are no base- or bolt-bound conditions.

Offset drive alignment methods

In offset drive alignment, correction of the angular misalignment is important, while offset misalignment is irrelevant.

There are various methods for measuring offset drive alignment. Traditional alignment methods, such as straightedges, cannot provide the desired level of accuracy. SKF recommends using laser technology, whenever possible.

Fig. 18

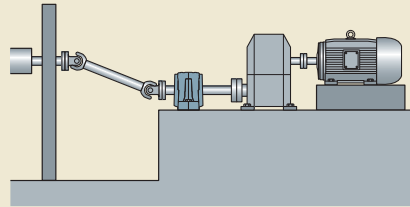
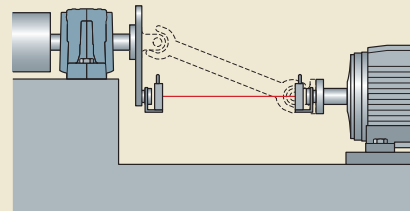


Fig. 19



Laser offset drive alignment methods

The trick to aligning offset drives is to cancel the offset by creating a virtual or “dummy” rotational centre, parallel to the driven shaft (→ **fig. 19**).

Rough alignment is achieved using a cardan fixture kit and a suitable twin laser shaft alignment tool.

Detailed instructions for use for laser alignment equipment are supplied with the equipment.

Belt alignment

Belt alignment or, more precisely, pulley alignment, is a principal maintenance activity. When pulleys are not aligned properly, additional loads are induced. The aim of belt alignment is to align the grooves of the drive and driven pulleys so that the belts run with minimal wear.

The benefits of properly aligned belts include:

- extended service life of belts and bearings
- reduced vibration and noise levels
- energy savings

Types of belt misalignment

If the grooves of the pulleys are not in line with each other, the belts are misaligned. There are three types of belt misalignment (→ **table 5**). In practice, more than one type of belt misalignment can exist at the same time.

CAUTION: Unless belt misalignment is corrected, a new belt will last no longer than the one it replaced!

Belt alignment tolerances

Belt manufacturers typically recommend a maximum horizontal angle misalignment from 1,0 to 0,25°. This accuracy can only be achieved with precision alignment tools such as laser equipment.

Belt alignment methods

There are two ways to align pulleys: Traditional and laser. The principal belt alignment methods are compared in **table 6** and described below.

SKF recommends using laser technology, whenever possible.

Traditional belt alignment methods

Traditional alignment methods are quick but often inaccurate. With these methods, mechanical tools such as straightedges, tape measures, wire, string, feeler gauges, spirit levels and calibrated cones are used.



Laser belt alignment methods

In contrast with traditional belt alignment tools, laser equipment enables measurements and adjustments to be made with incredible precision.

Laser belt alignment tools are grouped according to the parts of the pulleys that are aligned:

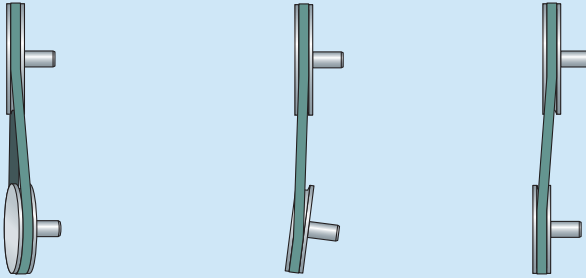
- the pulley grooves
- the pulley faces

Laser systems that align the pulley grooves, such as the SKF Belt alignment tool (→ **fig. 20**), provide superior accuracy to those that align the pulley faces. Aligning the pulley grooves is also preferred because pulleys of different thickness, brand, type or face quality can still be aligned accurately.

Detailed instructions for use of the SKF Belt alignment tool are supplied with the equipment.

Table 5

Types of belt misalignment



	Vertical angle (twisted) misalignment	Horizontal angle misalignment	Parallel misalignment
Description	The shafts of the drive and driven pulleys are parallel but one of the pulleys is twisted in the vertical plane	The shafts of the drive and driven pulleys are not parallel	The shafts of the drive and driven pulleys are parallel but one of the pulleys is too far forward (or backward)
Cause	The movable machine is incorrectly positioned in the vertical plane	The movable machine is incorrectly positioned in the horizontal plane	The movable machine is incorrectly positioned One of the pulleys is incorrectly adjusted on its shaft
Correction	Adjust the height of the front or rear feet of the movable machine	Slide the front or rear of the movable machine sideways	Move the movable machine forwards or backwards Move one of the pulleys forwards or backwards along the shaft

6

Table 6

Belt alignment methods

Type	Method	Usage	Advantages	Disadvantages
Traditional	Straightedge	Rough alignment	Simple equipment	Inaccurate
	Length of string/wire		Direct readings Relatively quick	Readings rely on naked eye approximation and the accuracy of the pulley face Several repetitions are required
Laser	Face alignment	Rough alignment	Good accuracy	Accuracy depends on the quality of the pulley face The faces are aligned and not the grooves
		Precision alignment	Also used for timing belts Specialized skills are not required	
	Groove alignment, e.g. using the SKF Belt alignment tool	Precision alignment	High accuracy Specialized skills are not required All three misalignment conditions are monitored simultaneously Corrections are followed real time	None



Lubrication

Introduction	180	Oil lubrication	203
Lubrication management	180	What is in an oil?	203
Inspection, handling and disposal of lubricants	181	Base oil	203
Grease versus oil	182	Additives	203
Alternative lubricants	182	Oil viscosity	203
Grease lubrication	183	How to select a suitable oil	203
What is in a grease?	183	Oil selection process	204
Base oil	183	Additional oil selection tools	207
Thickener	183	Oil lubrication systems	207
Additives	184	Types of oil lubrication systems	207
How grease functions in bearings	184	Maintaining oil lubrication systems	207
Interpreting grease datasheets	184	Chain oils	209
Grease properties	185	Oil compatibility	210
Greases and bearing operating conditions	187	Oil analysis	210
Grease performance tests	188	Oil sampling	210
Selecting a suitable grease	189	Contamination and filtering	211
Grease selection tools	189	SKF oil lubrication products	212
How to grease bearings and associated components on initial installation	189	Centralized lubrication systems	213
The best time to apply grease	189	Selecting the appropriate lubricant	213
The right quantity	190	Types of centralized lubrication systems	213
Greasing techniques when mounting	191	Total loss lubrication systems	214
Running-in of grease lubricated bearings	191	Circulating lubrication systems	214
Relubrication	192		
Relubrication intervals	192		
Relubrication procedures	194		
Renewal	198		
Grease compatibility	200		
Compatibility between greases	200		
Compatibility between greases and bearing materials	202		
Compatibility between greases and SKF bearing preservatives	202		
SKF grease lubrication products	202		

Introduction

To optimize the service life of a bearing arrangement, the correct amount of an appropriate lubricant must be delivered at the proper time. Just as an insufficient amount of lubricant will affect bearing performance negatively, so will an excessive amount of lubricant. Either way, the result can be the same: premature bearing failure and costly machine downtime.

Inadequate lubrication accounts for approximately 36% of all bearing failures. This includes failures caused by the following:

- improper lubricant selection
- insufficient lubricant
- excessive lubricant
- inappropriate relubrication intervals
- lubricant not reaching the bearing due to poor bearing arrangement design, incorrect machine assembly or blocked piping

Add to this the bearing failures caused by a contaminated lubricant supply and the percentage of lubrication-related bearing failures can jump as high as 50%.

Effective lubrication and good lubrication practices can help to significantly reduce premature bearing failures and machine downtime. To meet that goal, SKF offers a comprehensive assortment of lubricants and lubrication systems as well as programs to help with lubricant selection and determine relubrication intervals.

Only lubrication for rolling bearings is presented in this chapter. For information about lubricating other types of bearings, visit www.skf.com/bearings, or contact the SKF application engineering service.

For additional information about SKF maintenance and lubrication products and tools, visit www.skf.com/lubrication and www.mapro.skf.com.

For information about the SKF programs LuBase, DialSet and the SKF Lubrication Planner, visit www.skf.com/lubrication or www.apitudexchange.com.

The SKF Reliability Maintenance Institute (RMI) offers a comprehensive range of training courses in lubrication (→ *Training*, starting on **page 326**). Contact your local SKF representative for additional information, or visit www.skf.com/services.

Lubrication management

In a facility where there can be hundreds and maybe thousands of lubrication points, things can get confusing. But even when only a few lubrication points are involved, it is important to organize and document all lubrication-related information and implement a detailed lubrication management programme. Factors to take into consideration include:

- supply and storage of lubricants
- resources: equipment and manpower
- lubrication schedules and routes
- lubricant analysis and monitoring
- automatic versus manual lubrication

The SKF Lubrication Planner, available at www.skf.com/lubrication, is a user-friendly software that provides all basic features required to properly design and manage a lubrication plan.

Inspection, handling and disposal of lubricants

Inspection of lubricants

Regardless of the date of manufacture, greases and oils should be checked visually prior to use.

For grease, check for abnormal oil separation and any signs of mildew, water or discolouration.

For oil, check for any water or discolouration. If the oil looks cloudy, it usually means it is contaminated with water.

NOTE: When visually inspecting grease, keep in mind that some oil separation is normal.

Recommended lubricant handling practices

Proper lubricant handling procedures are very important. SKF recommends that you do the following:

- Wipe the edges of lubricant containers before opening them to prevent the entry of contaminants.
- Use clean containers when dispensing lubricants.
- Use professional tools.

CAUTION: Direct contact with petroleum products may cause allergic reactions! Read the material safety datasheets before handling lubricants and use protective gloves at all times.

Material safety datasheets

Material safety datasheets (MSDS) provide essential information about the physical and chemical properties of a lubricant. They also present recommended precautions and exposure control procedures.

NOTE: Material safety datasheets for SKF bearing greases are available online at www.mapro.skf.com.

Lubricant disposal

Improper disposal of lubricants can be hazardous to the community and the environment. Dispose of all lubricants in accordance with national and local laws and regulations and good environmental safety practices.

Lubrication

Grease versus oil

Grease is the most widely used lubricant for rolling bearings because it has many advantages over oil and is normally more cost-effective. Less than 20% of rolling bearings are lubricated with oil.

It is essential to match the lubricant to the application and operating conditions, but it is also important to consider the lubricant delivery method, installation and maintenance. When choosing between grease and oil lubrication, many factors should be taken into consideration (→ **table 1**).

Alternative lubricants

In some applications, solid oil can provide benefits that grease or oil alone cannot provide. Solid Oil is a polymer matrix saturated with lubricating oil, which completely fills the free space in a bearing. Solid oil has been developed specifically for applications where conventional lubrication has been previously unsuccessful or cannot be implemented, e.g. in bearing arrangements with limited accessibility.

Many SKF rolling bearings as well as bearing units can be supplied with Solid Oil. The bearings are identified by the designation suffix W64.

In extreme temperature applications, such as reheat furnaces and kilns, the high temperatures can cause normal lubricants to melt or

Table 1

Selection comparison between grease and oil

Selection criteria	Advantages/disadvantages		
	Grease	Oil	
Application and operating conditions	Associated components	Bearings and associated components need to be kept separate	Bearings and associated components can be lubricated with the same oil (where appropriate)
	Sealing solution	Improves sealing efficiency of enclosures	No sealing advantage
	Operating temperature	No cooling advantage Operating temperature limitations	Assists with cooling Suitable for high operating temperatures
	Speed factor	Speed limitations	Suitable for high operating speeds
	Shaft orientation	Suitable for vertical shafts	Typically not suitable for radial bearings on vertical shafts
	Food compatibility	Low risk of contamination from leakage	Only food grade oils should be used, due to the risk of leakage
Installation and maintenance	Installation	Quick Relatively inexpensive	Time consuming Expensive (pumps, baths etc. required)
	Lubricant retention and leakage	Retained easily in bearing housings	Amount of lubricant controlled easily Leakage likely
	Inspection	Difficult to inspect during operation	Must maintain oil level
	Applying the lubricant	Normally easy to apply	Time consuming
	Lubricant change	Difficult to remove all grease, but not a problem if greases are compatible	Easy to drain completely and refill reservoirs
	Contamination control	Difficult to control contamination	Can be filtered and reconditioned
	Quality control	Difficult to monitor	Easy to monitor

evaporate. For these challenging environments, SKF provides two dry lubricant alternatives:

- bearings with a solid, graphite-based lubricant compound, designation suffixes VA201, VA210 or VA2101
- bearings with a self-sacrificing graphite cage, designation suffixes VA208 or VA228

NOTE: Bearings filled with Solid Oil, solid graphite or graphite paste do not require relubrication.

Grease lubrication

What is in a grease?

Grease can be described as “thickened oil”. Rolling bearing grease is usually a suspension of base oil in a thickener, plus additives. By varying these ingredients, it is possible to produce several different greases for a wide variety of applications.

Base oil

The base oil makes up 70 to 95% of the grease and can be classified into one of three categories:

- mineral
- synthetic
- natural

Mineral base oils are refined crude petroleum products. The base oils in grease are normally mineral oils as these are appropriate for most applications.

Under special operating conditions, e.g. extremely low or high operating temperatures, synthetic base oils are preferred. Synthetic base oils are non-petroleum based products.

Natural base oils, i.e. animal and vegetable oils, are not normally used for rolling bearings because there is a risk of quality impairment and acid formation after a short time.

Thickener

The thickener constitutes 5 to 30% of the grease. It is the ingredient that retains the oil and additives, enabling the grease to function. The thickener also gives the grease “body”, enabling it to stay in place.

There are various thickeners, each having specific benefits directed at certain application

conditions. The broadest category of thickeners can be divided into soaps and non-soaps.

Soaps

The most common greases have metallic soap thickeners based on lithium (Li), calcium (Ca), sodium (Na) or aluminium (Al). Lithium soap is the most commonly used soap for bearing greases.

Complex soap greases are the result of a chemical reaction between a base metal and two dissimilar acids. These greases typically have increased performance capabilities and can withstand higher operating temperatures than the corresponding conventional soap greases.

Non-soaps

Non-soap thickeners are occasionally based on inorganic ingredients. Inorganic thickeners such as bentonite, clay and silica gel resist leakage at high operating temperatures and are water resistant. Polyurea is an example of a non-soap thickener.

Lubrication

Additives

Chemicals, known as additives, are added to grease to achieve or enhance certain performance characteristics. Some of the more common additives are listed in **table 2**.

Extreme pressure, anti-wear and solid additives

Extreme pressure (EP) additives can consist of many different compounds; examples include sulphur and phosphorous compounds. EP additives increase the load carrying capacity of the lubricant film under heavy loads.

Anti-wear (AW) additives form a protective layer on metal surfaces, similar to EP additives.

Solid additives, such as molybdenum disulphide (MoS₂) and graphite, are beneficial in grease, under low speed conditions, when the base oil may become ineffective.

How grease functions in bearings

The thickener in grease functions as a container for the base oil and behaves like a water-filled sponge. When a wet sponge is squeezed lightly, a small amount of water is released. When heavy pressure is applied to the sponge, more water is forced out.

Similarly, when a load is applied to grease, the thickener releases the base oil. This is known as oil bleeding or oil separation. When the load is released, the thickener normally absorbs the base oil again.

Interpreting grease datasheets

Grease datasheets provide information in three general categories:

- the properties of the grease
- the bearing operating conditions for which the grease is suitable
- the results of grease performance tests

Interpreting and understanding grease datasheets is essential for successful grease selection as well as for lubrication maintenance.

Table 2

Grease additives	
Additive	Function
Anti-rust	Improves the protection of the bearing surfaces offered by grease
Anti-oxidant	Delays the breakdown of the base oil at high temperatures, extending grease life
Extreme pressure (EP)	Reduces the damaging effects of metal-to-metal contact
Anti-wear (AW)	Prevents metal-to-metal contact by the formation of a protective layer
Solid additive	Provides lubrication when the base oil becomes ineffective

Grease properties

Grease datasheets typically provide information about important grease properties, including:

- NLGI consistency grade
- soap type
- dropping point
- base oil viscosity/type
- operating temperature range

NLGI consistency grade

Greases are divided into various consistency grades according to a scale developed by the US National Lubricating Grease Institute (NLGI). Greases with a high consistency, i.e. stiff greases, are assigned high NLGI grades, while those with a low consistency, i.e. soft greases, are given low NLGI grades.

There are nine NLGI grades in total. In rolling bearing applications, three grades from the scale are generally used: NLGI 1, 2 and 3.

NOTE: It is important to remember that the stiffness of grease has nothing to do with the base oil viscosity. Stiff grease can have a high or low base oil viscosity.

Soap type

The most common greases have lithium, calcium or sodium soaps as thickeners. Lithium and sodium soaps have a wide operating temperature range, typically up to 120 °C (250 °F). Calcium soaps only have an operating temperature range up to 80 °C (175 °F), but provide excellent protection against water, including salt water.

Complex soaps typically exhibit improved properties.

Dropping point

The dropping point of grease is the temperature at which the grease loses its consistency and becomes a fluid. This temperature does not represent the operating temperature limit of the grease.

Base oil viscosity/type

Viscosity is the resistance to the flow of a fluid. Different fluids have different viscosities. Water has a low viscosity because it has a low resistance to flow; honey has a high viscosity, because it does not flow easily.

Viscosity is temperature and pressure dependent. The viscosity of the base oil in grease decreases with rising temperature and increases with falling temperature. Conversely, the viscosity of the base oil in grease increases with increasing pressure.

CAUTION: With every 10 to 15 °C (18 to 27 °F) increase in temperature, the viscosity of a mineral base oil drops by a factor of two!

The base oil viscosity in grease is specified at two temperatures:

- the internationally standardized reference temperature, i.e. 40 °C (105 °F)
- a high temperature, typically 100 °C (210 °F)

With this information, it is possible to calculate the base oil viscosity at operating temperature. For information about viscosity calculations, refer to *How to select a suitable oil* starting on **page 204**.

Lubrication

Operating temperature range – The SKF traffic light concept

The temperature range for greases is divided by four temperature limits into five zones:

- low temperature limit (LTL)
- low temperature performance limit (LTPL)
- high temperature performance limit (HTPL)
- high temperature limit (HTL)

SKF illustrates this schematically in the form of a “double traffic light” (→ **fig. 1**).

The low temperature limit (LTL) is the lowest temperature at which grease will enable a bearing to start operating without difficulty. The LTL is largely determined by the type of base oil and its viscosity.

The high temperature limit (HTL) is established by the grease’s dropping point, i.e. the temperature when grease becomes a fluid.

SKF does not recommend start-up above the HTL or below the LTL. In fact, SKF recommends performance limits well within the manufacturer’s recommended temperature limits. These are referred to as the high and low temperature performance limits. It is within these two limits, the green zone in **fig. 1**, where the grease functions reliably and grease life can be determined.

Since the definition of the high temperature performance limit (HTPL) is not standardized internationally, care must be taken when interpreting manufacturers’ data.

At temperatures above the HTPL, grease will age and oxidize with increasing rapidity and the by-products of the oxidation can have

Fig. 1

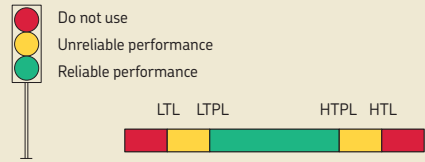


Table 3

Bearing operating temperatures (grease datasheets)

Temperature description	Definition
Low (L)	< 50 °C (120 °F)
Medium (M)	50 to 100 °C (120 to 210 °F)
High (H)	> 100 °C (210 °F)
Extremely high (EH)	> 150 °C (300 °F)

Table 4

Bearing speeds for standard bearings (grease datasheets)

Speed description	Bearing speed factor A for Radial ball bearings	Cylindrical roller bearings		Tapered roller bearings Spherical roller bearings CARB toroidal roller bearings
–	mm/min			
Very low (VL)	–	< 30 000		< 30 000
Low (L)	< 100 000	< 75 000		< 75 000
Moderate (M)	< 300 000	< 270 000		< 210 000
High (H)	< 500 000	≥ 270 000		≥ 210 000
Very high (VH)	< 700 000	–		–
Extremely high (EH)	≥ 700 000	–		–

a detrimental effect on lubrication. Therefore, operating temperatures in the amber zone between the HTPL and the HTL, should occur only for very short periods.

An amber zone also exists for low temperatures. With decreasing temperature, the tendency of grease to bleed oil decreases and the stiffness (consistency) of the grease increases. This will ultimately lead to an insufficient supply of lubricant to the contact surfaces of the rolling elements and raceways. In **fig. 1**, this temperature limit is indicated by the low temperature performance limit (LTPL). Short periods in the amber zone, e.g. during a cold start, in general are not harmful since the heat caused by friction will bring the bearing operating temperature into the green zone.

Greases and bearing operating conditions

Grease datasheets provide information about suitable bearing operating conditions with regard to:

- temperature
- speed
- load

These descriptions, however, are expressed using general terms such as “low” or “very high” and require interpretation.

Temperature

The operating temperature of a bearing is measured as close to the bearing outside diameter as possible, and is influenced by the ambient temperature. A measured operating temperature of 100 °C (210 °F) or above is generally considered “high”.

Information about bearing operating temperatures in grease datasheets can be interpreted using the guidelines in **table 3**.

Speed

The operating speed reference in grease datasheets is based on the speed factor of the bearing. The speed factor compares the speed capability of bearings and is expressed as

Table 5

Bearing loads (grease datasheets)	
Load description	Load ratio
Light (L)	$P \leq 0,05 C$
Moderate (M)	$0,05 C < P \leq 0,1 C$
Heavy (H)	$0,1 C < P \leq 0,15 C$
Very heavy (VH)	$P > 0,15 C$

$$A = n d_m$$

where

A = speed factor [mm/min]

n = rotational speed [r/min]

d_m = bearing mean diameter
= $0,5 (D + d)$ [mm]

Information about bearing operating speeds in grease datasheets can be interpreted using the guidelines in **table 4**.

Load

Reference made to bearing load in grease datasheets is based on the ratio between the dynamic load rating C of the bearing and the equivalent load P on the bearing (the load to which the bearing is subjected). Therefore:

- The smaller the equivalent load P, the bigger the ratio C/P is and the more lightly loaded the bearing becomes.
- The bigger the equivalent load P, the smaller the ratio C/P is and the more heavily loaded the bearing becomes.

Information about bearing loads in grease datasheets can be interpreted using the guidelines in **table 5**.

Lubrication

Grease performance tests

The remaining part of a grease datasheet typically contains results of laboratory tests performed on samples of the grease.

The test results can be interpreted using the guidelines in **table 6**.

Table 6

Grease performance tests			
Test	What this means	Measurement [unit]	Interpretation of results
Dropping point	The temperature at which the grease begins to flow	Temperature [°C]	–
Penetration	Consistency, the stiffness of the grease (NLGI grade)	Depth of cone penetration Value between 85 and 475 [10 ⁻¹ mm] (60 or 100 000 strokes)	High number = soft grease Low number = stiff grease
Roll stability	How easily the grease softens or hardens	Change in cone penetration depth [10 ⁻¹ mm]	High number = less stable Low number = more stable
Mechanical stability	The mechanical stability of the grease when subjected to vibration	Rating, dependent on the mass of the leaked grease (SKF V2F rating)	M = very little grease leakage m = some grease leakage Fail = a lot of grease leakage
Corrosion protection	The degree of corrosion of the grease when mixed with water	Value between 0 and 5 (SKF EMCOR rating ¹⁾)	0 = no corrosion 5 = very severe corrosion
Oil separation	The amount of oil that leaks through a sieve during storage	Percentage weight loss [%] (DIN 51817)	0% = no oil separation 100% = complete oil separation
Water resistance	The change in grease after water immersion	Value between 0 and 3 (based on visual inspection) (DIN 51807/1)	0 = no change 3 = major change
Lubricating ability	The lubricating ability of the grease under operating conditions typical of large bearings (d ≥ 200 mm)	Rating, dependent on the ability of the grease to lubricate large bearings under normal or high temperature conditions (SKF R2F grease test machine)	Unheated test (normal temperature conditions) Pass = grease is suitable Fail = grease is not suitable Heated test (high temperature conditions) Pass = grease is suitable Fail = grease is not suitable
Copper corrosion	The degree of protection of copper alloys offered by the grease	Value between 1 and 4 (based on visual inspection) (DIN 51811)	1 = good protection 4 = very bad protection
Rolling bearing grease life	The grease life	Time to bearing failure [hours] (SKF ROF grease test machine)	–
EP performance (VKA test)	The ability to classify the grease as an EP grease	Extreme pressure limit of the grease [N] (DIN 51350/4)	–
Fretting corrosion	The ability of the grease to protect against fretting corrosion	Bearing wear [mg] (ASTM D4170)	–

¹⁾ Standardized in accordance with ISO 11007.

Selecting a suitable grease

All precautions taken to prevent premature bearing failure count for little if the wrong grease is selected. Therefore, grease selection is critical to the operational success of any machine. Grease based on a mineral oil and lithium thickener with an NLGI 2 grade is sufficient for most applications. However, consider all contributing factors as discussed below.

Gather all relevant information before starting the selection process:

- application
- bearing type and overall dimensions
- bearing load
- operating and ambient temperatures
- rotational speed
- shaft orientation
- external influences e.g. vibration, oscillation
- contamination details

CAUTION: Before selecting the initial grease or switching to a different grease, be sure to check the machine manufacturer's documentation. Not all greases are compatible with each other and there could be components within the machine that are not compatible with some lubricant additives.

Grease selection tools

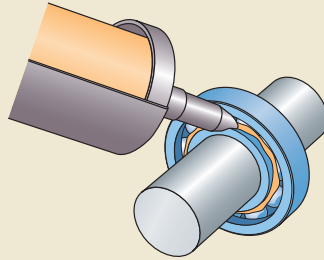
The SKF grease selection program, LubeSelect, can be used to select an appropriate SKF grease. Another SKF program, LuBase, contains details about more than 2 000 lubricants provided by more than 100 lubricant suppliers. Both programs are available online at www.aptitudexchange.com.

An SKF bearing grease selection chart is provided in **Appendix M**, on **pages 430 to 431**. For additional information about how to select a suitable grease, visit www.skf.com/bearings.

How to grease bearings and associated components on initial installation

Most open rolling bearings are supplied ungreased. They are, however, protected with a rust inhibiting preservative. The rust inhibitor on SKF bearings is compatible with most lubricants and additives (except for example SKF LGET 2) and does not need to be washed off before initial greasing. Bearings with a shield or seal fitted on both sides are greased at the factory and do not require additional grease when mounting.

Fig. 2



WARNING

SKF LGET 2, a fluorinated grease, is not compatible with other greases, oils and preservatives. Therefore, a very thorough washing of the bearings and cleaning of the systems is essential before applying fresh grease.

CAUTION: Never wash a bearing that has a seal or shield fitted on both sides.

The best time to apply grease

Generally, open bearings are lubricated after mounting (→ **fig. 2**). The most important reason for this is cleanliness. The later the grease is applied, the less chance there is that contaminants will enter into the bearing.

Bearings should be lubricated prior to mounting when there is no other way to get grease into the bearing.

Lubrication

The right quantity

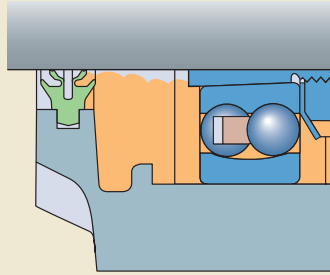
As a general rule, for bearings mounted in housings, the bearings should be completely filled (100%) with grease prior to start-up.

The free space in the housing should be partially filled (30 to 50%) with grease (→ **fig. 3**). In non-vibrating applications, where bearings are to operate at very low speeds and good protection against contamination is required, SKF recommends filling up to 90% of the free space in the housing with grease.

An alternative for highly contaminated environments is to fill the housing completely and use a sealed SKF bearing. This triple layer of protection uses the housing seal, grease in the housing, and bearing seal to protect the bearing and lubricant inside the bearing from even the very smallest contaminants.

CAUTION: Always leave free space in the housing so that grease, ejected from the bearing during start-up, has somewhere to go. If the housing is completely filled, churning can result, which can increase the operating temperature by as much as 50 °C (90 °F). The grease might also be burnt leading to lubricant starvation. If running-in cannot be done, the initial grease fill should be reduced to a maximum of 30% of the free volume in the bearing.

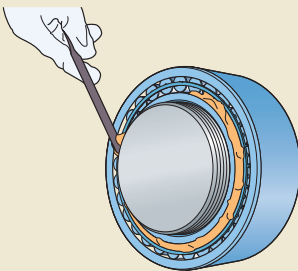
Fig. 3



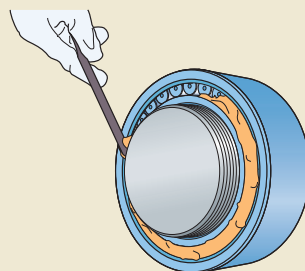
When labyrinth seals are fitted, the radial or axial gaps in the labyrinth arrangement should be fully packed with grease.

Double-lip seals and seals with a contacting auxiliary lip should also be fully packed with grease because the grease not only acts as a seal but it also decreases underlip temperatures.

Fig. 4



a) Greasing CARB toroidal roller bearings with a cage (high-speed operation)



b) Greasing full complement CARB toroidal roller bearings

CARB toroidal roller bearings

CARB toroidal roller bearings have a relatively large free space available for grease (→ fig. 4). If these bearings are fully greased and run at relatively high speeds (> 75% of the reference speed), elevated operating temperatures can be expected. Therefore, SKF recommends filling only the space between the inner ring and the cage of the bearing with grease (a).

For full complement CARB bearings or CARB bearings operating at low or moderate speeds, the bearings should be completely filled with grease (b).

High- and super-precision bearings

High- and super-precision bearings should generally be lubricated with small quantities of grease. In machine tool applications, which mostly run at high to very high speeds, less than 30% of the free space in the bearings should be filled with grease. From experience in the field, the most common grease fill is about 10 to 15% of the free space in the bearing.

For additional information about greasing high- and super-precision bearings, visit www.skf.com/bearings.

Greasing techniques when mounting

Greasing techniques vary according to the design of the bearings and their housings. Bearings can be either separable or non-separable; housings either split or one-piece. A few guidelines for greasing bearings are presented here.

For information about mounting bearings, refer to *Mounting rolling bearings*, starting on page 44.

Separable bearings

Separable bearings include cylindrical roller and tapered roller bearings, four-point contact ball bearings, and all types of thrust bearings. These bearings should be greased while separated in the order determined by the mounting sequence. Make sure the free space between the rolling elements and cage is filled completely with grease. If the rolling element and cage assembly is separable from both rings, grease the raceway of one of the rings lightly to avoid damaging the surface when the rolling element and cage assembly is pushed back onto the ring.

Non-separable bearings

Non-separable bearings, such as deep groove and angular contact ball bearings, can be filled preferably with grease from both sides during the mounting process.

For self-aligning ball bearings, spherical roller bearings and CARB toroidal roller bearings, one bearing ring can be swivelled to facilitate greasing. The bearings should then be turned a few times to distribute the grease evenly.

CAUTION: When swivelling the ring of a CARB toroidal roller bearing or self-aligning bearing, the lower rolling elements can drop slightly. This can cause the rolling elements to jam against the outer ring when swivelling it back into position and damage the bearing. To avoid this, guide the rolling elements smoothly back into place.

Greasing bearings prior to mounting

Open bearings that cannot be greased after mounting should be greased as follows before mounting:

- 1 Place the bearing on a clean plastic sheet.
- 2 Chock larger bearings or use a v-block to keep the bearing in place.
- 3 Fill the free space, from both sides, between the rolling elements and cage with grease, using a grease packer. For self-aligning bearings, swivel one of the bearing rings, exposing the rolling elements, and then apply the grease.
- 4 If the bearing cannot be mounted immediately, wrap it in plastic.

Running-in of grease lubricated bearings

During initial start-up, the temperature in a newly greased bearing will rise. Therefore, if possible, SKF recommends running-in bearings before operating at full speed. This is particularly important for high-speed applications. Without a running-in period, the temperature rise can be considerable.

Running-in a bearing involves operating the bearing at increasing speeds from a low initial speed. At the end of the running-in period, the grease will be distributed throughout the bearing arrangement and the operating temperature will have stabilized.

Lubrication

Relubrication

Grease does not last forever. Under the influence of time, temperature, mechanical working, ageing and the ingress of contaminants, grease in a bearing arrangement deteriorates and gradually loses its lubricating properties. Relubrication is the addition of fresh grease into a bearing arrangement after a certain period of operation.

There are three critical factors to proper relubrication: the type of grease, the quantity of grease and the relubrication interval. The quantity of grease and relubrication interval depend greatly on whether the grease is applied manually or automatically.

Sealed bearings are normally lubricated for life and typically do not require relubrication. However, when operating conditions are arduous, relubrication might be necessary. Therefore, a number of sealed bearing types have relubrication features.

Relubrication intervals

Relubrication intervals depend on many related factors. Be sure to check the machinery manufacturer's recommendations prior to developing a relubrication programme. If that is not possible, gather all relevant information before calculating relubrication intervals:

- application
- bearing type and boundary dimensions
- bearing load
- operating and ambient temperatures
- rotational speed
- shaft orientation
- external influences, e.g. vibration, oscillation
- contamination details

The relubrication interval t_r can be obtained from **diagram 1** as a function of:

- the speed factor A
- the bearing factor b_r
- the load ratio C/P

where

$A = n d_m$ [mm/min]

n = rotational speed [r/min]

d_m = bearing mean diameter
= 0,5 (d + D) [mm]

b_r = bearing factor depending on the bearing type, and load conditions (for axially loaded spherical roller bearings) (→ **table 7, page 194**)

If a bearing failure analysis indicates that there has been a problem with heat and/or lubrication, first check that the appropriate grease was used. If so, check the recommended limits for the speed factor A in **table 7, page 194**. If the speed factor of the application is greater than those listed, switching to an oil bath or circulating oil system may substantially increase bearing service life.

The relubrication intervals in **diagram 1** are estimates, based on the following operating conditions:

- an operating temperature of 70 °C (160 °F)
- lubrication with good quality lithium based grease
- a horizontal shaft
- a rotating inner ring
- a clean environment

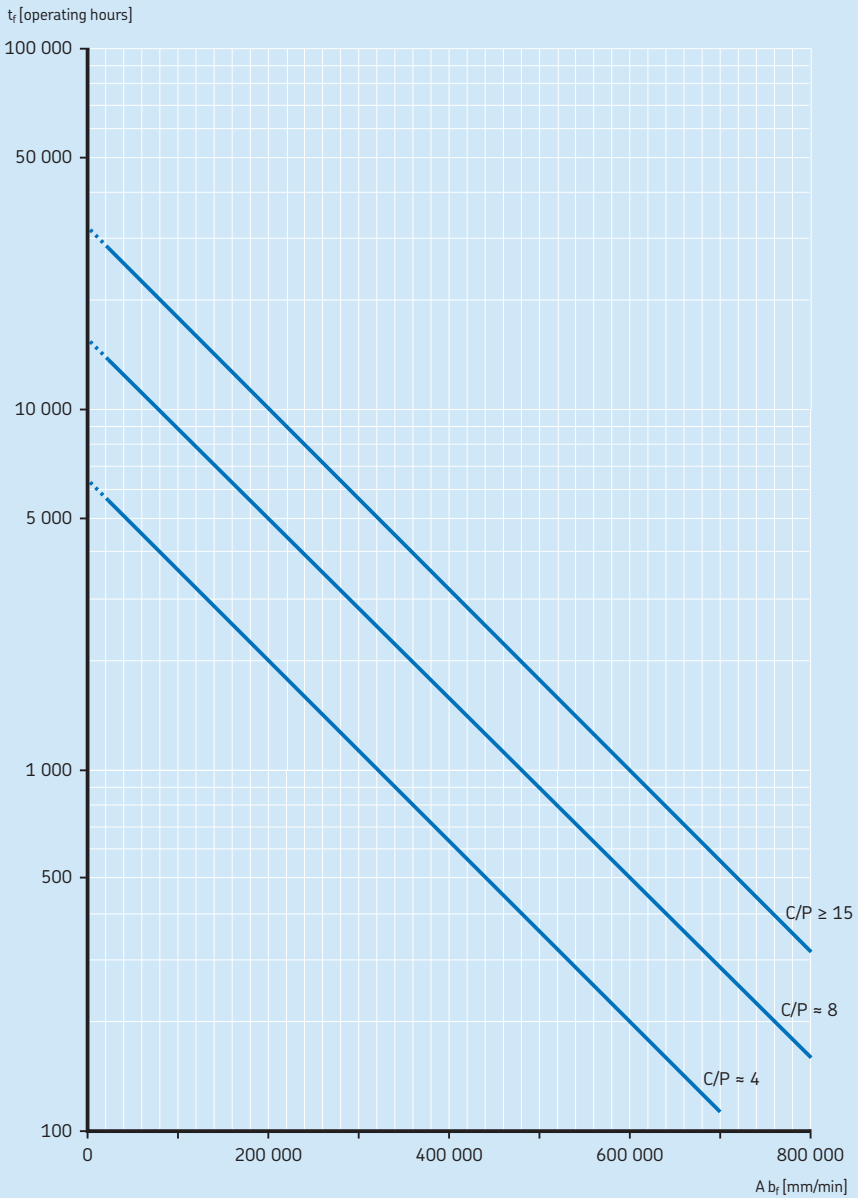
When bearing operating conditions differ, adjust the relubrication intervals according to the information provided in **table 8, page 195**.

NOTE: When using different bearings in an assembly, apply the shortest calculated relubrication interval to all bearings.

The SKF grease selection program, LubeSelect, available online at www.apitudexchange.com, can also be used to calculate relubrication intervals.

Diagram 1

Relubrication intervals at 70 °C (160 °F)



Relubrication procedures

The choice of a relubrication procedure generally depends on the application, the operating conditions and the relubrication interval t_r . There are two primary relubrication procedures: replenishment and continuous relubrication (→ table 9).

Table 7

Bearing factors and recommended limits for the speed factor A

Bearing type ¹⁾	Bearing factor b_f	Recommended limits for the speed factor A, for load ratio		
		$C/P \geq 15$	$C/P \approx 8$	$C/P \approx 4$
–	–	mm/min		
Deep groove ball bearings	1	500 000	400 000	300 000
Angular contact ball bearings	1	500 000	400 000	300 000
Self-aligning ball bearings	1	500 000	400 000	300 000
Cylindrical roller bearings				
• non-locating bearing	1,5	450 000	300 000	150 000
• locating bearing, without external axial loads or with light but alternating axial loads	2	300 000	200 000	100 000
• locating bearing, with constantly acting light axial load	4	200 000	120 000	60 000
• without a cage, full complement ²⁾	4	NA ³⁾	NA ³⁾	20 000
Tapered roller bearings	2	350 000	300 000	200 000
Spherical roller bearings				
• when $F_r/F_e \leq e$ and $d_m \leq 800$ mm				
– series 213, 222, 238, 239	2	350 000	200 000	100 000
– series 223, 230, 231, 232, 240, 248, 249	2	250 000	150 000	80 000
– series 241	2	150 000	80 000 ⁴⁾	50 000 ⁴⁾
• when $F_r/F_e \leq e$ and $d_m > 800$ mm				
– series 238, 239	2	230 000	130 000	65 000
– series 230, 231, 240, 248, 249	2	170 000	100 000	50 000
– series 241	2	100 000	50 000 ⁴⁾	30 000 ⁴⁾
• when $F_r/F_e > e$				
– all series	6	150 000	50 000 ⁴⁾	30 000 ⁴⁾
CARB toroidal roller bearings				
• with a cage	2	350 000	200 000	100 000
• without a cage, full complement ²⁾	4	NA ³⁾	NA ³⁾	20 000
Thrust ball bearings	2	200 000	150 000	100 000
Cylindrical roller thrust bearings	10	100 000	60 000	30 000
Spherical roller thrust bearings				
• rotating shaft washer	4	200 000	120 000	60 000

¹⁾ The bearing factors and recommended practical limits for the speed factor A apply to bearings with standard internal geometry and standard cages. For alternative internal bearing designs and special cages, contact the SKF application engineering service.

²⁾ The t_r value obtained from **diagram 1, page 193** needs to be divided by a factor of 10.

³⁾ Not applicable. For these C/P values, SKF does not recommend a full complement bearing, but a bearing with a cage instead.

⁴⁾ For higher speeds, oil lubrication is recommended.

Table 8

Relubrication interval adjustments			
Operating condition / bearing type	Description	Recommended adjustment of t_r	Reason for adjustment
Operating temperature	For every 15 °C (27 °F) above 70 °C (160 °F), up to the high temperature limit (HTL)	Halve the interval	To account for the accelerated ageing of grease at higher temperatures
	For every 15 °C (27 °F) under 70 °C (160 °F)	Double the interval (maximum two times) ¹⁾	To account for the reduced risk of ageing of grease at lower temperatures
Shaft orientation	Bearings mounted on a vertical shaft	Halve the interval	The grease tends to leak out due to gravity
Vibration	High vibration levels and shock loads	Reduce the interval ²⁾	The grease tends to "slump" in vibratory applications, resulting in churning
Outer ring rotation	Outer ring rotation or eccentric shaft weight	Calculate the speed factor A using D, not d_m	The grease has a shorter grease life under these conditions
Contamination	Heavy contamination or the presence of fluid contaminants	Reduce the interval ^{2) 3)}	To reduce the damaging effects caused by contaminants
Load	Very heavy loads i.e. $P > 0,15 C$	Reduce the interval ²⁾	The grease has a shorter grease life under these conditions
Bearing size	Bearings with a bore diameter $d > 300$ mm	Reduce the interval ²⁾	These are typically critical arrangements, which require strict, frequent relubrication programmes
Cylindrical roller bearings	Bearings fitted with J, JA, JB, MA, MB, ML, MP and PHA cages ⁴⁾	Halve the interval	Oil bleeding is limited with these cage designs

¹⁾ For full complement and thrust bearings, do not extend the interval.
²⁾ Contact the SKF application engineering service.
³⁾ For severely contaminated conditions, consider sealed SKF bearings or continuous relubrication.
⁴⁾ For P, PH, M and MR cages, there is no need for adjustment.

7

Table 9

Relubrication procedures				
Relubrication procedure	Suitable relubrication interval t_r	Advantages	Disadvantages	Requirements
Replenishment	$t_r < 6$ months	Uninterrupted operation	Lubrication ducts in the bearing housing required	Bearing housings equipped with grease fittings
			Labour intensive	Grease gun
			Easy access to the bearing housing required	
Continuous relubrication	t_r is very short	Ideal for difficult access points Low risk of contamination Not labour intensive Continuous monitoring of lubrication possible Uninterrupted operation	High risk of contamination	
			Good pumpability of grease required (especially at low ambient temperatures)	Automatic lubricators or centralized lubrication systems

Lubrication

Replenishment

Since only the grease in the bearing should be replaced, the quantity needed for replenishment depends purely on the size of the bearing.

Some bearings are provided with relubrication features in the inner or outer ring to facilitate efficient relubrication through the centre of the bearing (→ **fig. 5**). The suitable quantity of grease for replenishment is then

$$G_p = 0,002 D B$$

Other bearings can only be relubricated from the side (→ **fig. 6**). The suitable quantity of grease for replenishment is then

$$G_p = 0,005 D B$$

where

G_p = grease quantity to be added when replenishing [g]

D = bearing outside diameter [mm]

B = total bearing width (for thrust bearings, use height H) [mm]

Bearing arrangements in housings that have contact seals, i.e. double-lip or four-lip seals, should be equipped with a grease escape hole to enable used and excess grease to purge from the arrangement. The escape hole should be positioned on the same side as the lock nut and therefore, on the side opposite the grease fitting (→ **fig. 7**).

Bearing arrangements with non-contact seals such as labyrinth seals do not require a

grease escape hole as the used and excess grease is pressed out between the gaps of the labyrinth when fresh grease is introduced (→ **fig. 8**).

Grease should be replenished in the early stages of lubricant deterioration. For grease replenishment, SKF recommends the following:

- 1 If a different grease is being introduced, check that the greases are compatible (→ *Grease compatibility*, starting on **page 200**).
- 2 Clean the grease fitting.
- 3 Replenish the grease while the machine is operating. If this is not possible, rotate the shaft by hand.
- 4 Where long lubrication ducts and low ambient temperatures exist, check that the grease is pumping adequately by checking that there is no excessive oil separation as a result of the pumping action.
- 5 After three to five replenishments, if possible, renew the grease fill (→ *Renewal*, starting on **page 198**).

CAUTION: Do not apply more grease than is appropriate. If grease leaks out of the contact seals from overfilling, this could damage the seals and cause overheating and premature bearing failure.

Fig. 5

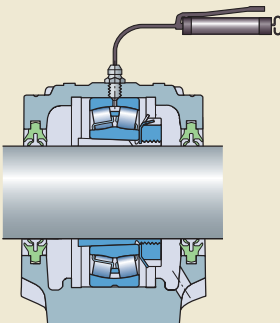
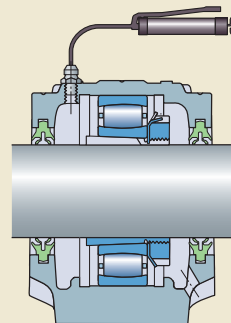


Fig. 6



Continuous relubrication

Continuous relubrication is used, for example, for high-speed applications where a small quantity of lubricant is continuously required. It is also used in highly contaminated environments where continuous lubrication is necessary to keep contaminants out.

Automatic lubrication solutions are designed for continuous lubrication or when lubrication points are difficult or dangerous to access, or when the reliability on the relubrication tasks needs to be improved. The main advantage of automatic lubrication is that it provides more accurate control over what lubricant and how much of it is supplied to each lubrication point. In addition, the risk of contamination associated with manual greasing using grease guns is reduced.

The quantity of grease required for continuous relubrication can be calculated approximately by

$$G_k = (0,3 \dots 0,5) D B \times 10^{-4}$$

where

G_k = grease quantity to be continuously supplied [g/h]

D = bearing outside diameter [mm]

B = total bearing width (for thrust bearing use total height H) [mm]

Alternatively, the calculated replenishment quantity G_p (→ *Replenishment*, **page 196**) can be spread over the relubrication interval.

SKF manufactures single point and multi-point automatic lubricators such as the SKF SYSTEM 24 lubricators. Centralized lubrication systems provide another option for automatic lubrication (→ *Centralized lubrication systems*, starting on **page 213**).

Fig. 7

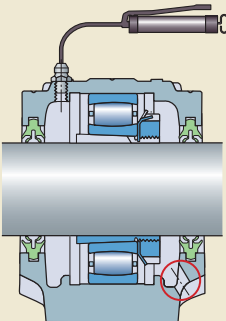
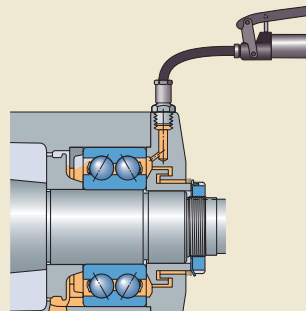


Fig. 8



- 6 Fill 30 to 50% of the housing with grease (typical quantity for normal applications).
- 7 Put the housing cap back in position.
- 8 Run-in the bearing.

When housings are not easily accessible but are provided with grease fittings and a grease escape hole, SKF recommends the following:

CAUTION: If a different grease is being introduced, check that the greases are compatible (→ *Grease compatibility*, starting on **page 200**).

- 1 Make sure the grease escape hole is open.
- 2 Clean the grease fitting.
- 3 Introduce fresh grease steadily (not too fast) via the grease fitting, while the machine is operating.
- 4 Capture the old grease expelled from the escape hole in a container.
- 5 Continue to add fresh grease until fresh grease is expelled from the escape hole.

CAUTION: Adding too much grease or too quickly without the ability to purge will result in churning and high operating temperatures.

Table 10

SKF SYSTEM 24 lubricators

Property	Lubricator LAGD 60	LAGD 125	LAGE 125	LAGE 250
Grease capacity	60 ml	125 ml	122 ml	250 ml
Nominal emptying time	1 to 12 months (adjustable)	1 to 12 months (adjustable)	1, 3, 6, 9 or 12 months (adjustable)	1, 3, 6, 9 or 12 months (adjustable)
Ambient temperature range	-20 to +60 °C (-5 to +140 °F)	-20 to +60 °C (-5 to +140 °F)	0 to +55 °C (30 to 130 °F)	0 to +55 °C (30 to 130 °F)
Ordering designation for pre-filled lubricators	LAGD 60/lubricant	LAGD 125/ lubricant	LAGE 125/ lubricant	LAGE 250/ lubricant
Suitable SKF greases	LGWA 2	LGWA 2, LGEM 2, LGFP 2, LGHB 2, LGHP 2, LGGB 2, LGWM 2	LGWA 2, LGEM 2, LGFP 2, LGHB 2, LGHP 2, LGWM 2	LGWA 2, LGEM 2, LGFP 2, LGHB 2, LGHP 2, LGWM 2
Suitable SKF chain oils ¹⁾	–	LHMT 68, LHHT 265, LHFP 150	LHMT 68, LHHT 265, LHFP 150	LHMT 68, LHHT 265, LHFP 150

¹⁾ For additional information about SKF chain oils, refer to **table 16** on **page 209**.

Lubrication

Grease compatibility

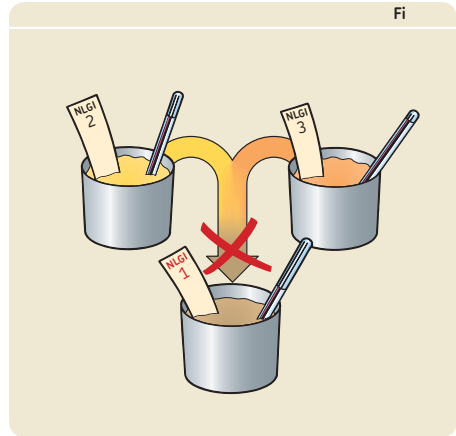
Before changing from one grease type to another, check that the two greases are compatible. Also, since grease in a bearing arrangement makes contact with the entire bearing, the grease should be compatible with all bearing materials and any bearing preservatives or coatings.

Compatibility between greases

Greases with the same thickener and similar base oils can generally be mixed without any problems. However, if two incompatible greases are mixed, the resulting mixture usually has a softer consistency (→) and can cause premature bearing failure through grease leakage from the bearing. The mixture also has a lower maximum operating temperature and the lubricant film (in operation) has a lower load carrying capacity than that of the individual greases.

CAUTION: It is generally good practice not to mix greases. If the original grease type is unknown, first completely remove the old grease and then refill (→ *Renewal*, starting on p).

To determine if two greases are compatible, compare the base oils (→) and thickeners (→).



WARNING

SKF LGET 2, a fluorinated grease, is not compatible with other greases, oils and preservatives. Therefore, a very thorough washing of the bearings and cleaning of the systems is essential before applying fresh grease.

Table 11

Base oil compatibility

	Mineral/PAO	Ester	Polyglycol	Silicone: methyl	Silicone: phenyl	Polyphenyl- ether	PFPE
Mineral/PAO	+	+	-	-	+	0	-
Ester	+	+	+	-	+	0	-
Polyglycol	-	+	+	-	-	-	-
Silicone: methyl	-	-	-	+	+	-	-
Silicone: phenyl	+	+	-	+	+	+	-
Polyphenylether	0	0	-	-	+	+	-
PFPE	-	-	-	-	-	-	+

+ = Compatible 0 = Test required - = Incompatible

Table 12

Thickener compatibility

	Lithium	Calcium	Sodium	Lithium complex	Calcium complex	Sodium complex	Barium complex	Aluminium complex	Clay	Common polyurea ¹⁾	Calcium sulphonate complex
Lithium	+	0	-	+	-	0	0	-	0	0	+
Calcium	0	+	0	+	-	0	0	-	0	0	+
Sodium	-	0	+	0	0	+	+	-	0	0	-
Lithium complex	+	+	0	+	+	0	0	+	-	-	+
Calcium complex	-	-	0	+	+	0	-	0	0	+	+
Sodium complex	0	0	+	0	0	+	+	-	-	0	0
Barium complex	0	0	+	0	-	+	+	+	0	0	0
Aluminium complex	-	-	-	+	0	-	+	+	-	0	-
Clay	0	0	0	-	0	-	0	-	+	0	-
Common polyurea ¹⁾	0	0	0	-	+	0	0	0	0	+	+
Calcium sulphonate complex	+	+	-	+	+	0	0	-	-	+	+

+ = Compatible 0 = Test required - = Incompatible

¹⁾ SKF LGHP 2 has been tested successfully for compatibility with lithium and lithium complex thickened greases.

Lubrication

Symptoms of grease incompatibility

The following symptoms, observed during operation, are typical of grease incompatibility:

- lubricant leakage
- lubricant hardening
- lubricant colour change
- increased operating temperature

Quick compatibility test

A quick test, based on thickener compatibility (mechanical stability) and base oil compatibility (surface wetting) can be performed as follows:

- 1 Put equal amounts of each grease type into a container.
- 2 Stir the mixture with a rod.
- 3 Pour the mixture into another container.

If the mixture hardens, or becomes much softer and pours more easily from the container than either of the original greases, the greases are probably incompatible.

CAUTION: This quick compatibility test is only a guideline! SKF recommends actual laboratory tests to determine compatibility.

Compatibility between greases and bearing materials

SKF bearing greases are compatible with most bearing materials. However, keep the following in mind:

- Grease containing EP additives may react adversely with polyamide 66 cages above 100 °C (210 °F).
- Grease containing sulphur EP additives may attack brass cages above 100 °C (210 °F).
- Grease based on an ester oil is not compatible with seals made from acrylic rubber (ACM).

Compatibility between greases and SKF bearing preservatives

SKF bearings are treated with a petroleum based preservative that is compatible with the majority of bearing greases. However, the preservative is not compatible with synthetic fluorinated oil based greases with a PTFE thickener such as SKF LGET 2. With such greases, it is important to wash and dry the bearings carefully before applying this grease.

To remove the preservative from a bearing, wear grease resistant gloves and use a suitable detergent. The detergent evaporates quickly and the grease should be applied immediately afterwards to prevent the surfaces rusting.

SKF grease lubrication products

SKF offers a wide assortment of bearing greases and grease lubrication equipment, covering most application requirements (→ **Appendix L**, starting on **page 420**). More details about bearing greases from SKF and a grease selection guide are provided in **Appendix M**, starting on **page 423**. For additional information, visit www.mapro.skf.com and www.skf.com/lubrication.

Oil lubrication

What is in an oil?

Lubricating oil consists of base oil mixed with additives.

Base oil

The base oil makes up approximately 95% of lubricating oil and is classified into three groups:

- mineral
- synthetic
- natural

Mineral base oils are petroleum-based products. These oils are generally preferred for rolling bearing lubrication.

Synthetic base oils are generally considered for bearing lubrication under special operating conditions, e.g. at very low or very high operating temperatures. The term synthetic oil covers a wide range of different base stocks including polyalphaolefins (PAO), polyalkyleneglycols (PAG) and esters.

Natural base oils, i.e. animal and vegetable oils, are not normally used for rolling bearings because there is a risk of quality impairment and acid formation after a short time.

Additives

Chemicals, known as additives, are added to base oils to achieve or enhance certain performance properties. The additives are often grouped according to their function, e.g. performance, lubricant protective or surface protective additives.

Some of the more common additives are listed in **table 13**.

Oil viscosity

The most important property of lubricating oil is viscosity. Viscosity is the resistance of a fluid to flow and is dependent on temperature and pressure. Viscosity decreases with rising temperature and increases with falling temperature. High viscosity oil flows less readily than thinner, low viscosity oil.

The viscosity of oil is typically specified at the internationally standardized reference temperature, i.e. 40 °C (105 °F).

Table 13

Oil additives	
Additive	Function
Anti-rust	Improves the protection of the bearing surfaces offered by oil (water or oil soluble)
Anti-oxidant	Delays the breakdown of the base oil at high temperatures, extending lubricant life
Anti-foaming	Prevents bubble formation
Extreme pressure (EP)	Reduces the damaging effects of metal-to-metal contact
Anti-wear (AW)	Prevents metal-to-metal contact
Solid additive	Provides lubrication when the base oil becomes ineffective

Viscosity index (VI)

The viscosity-temperature relationship of oil is characterized by the viscosity index (VI). If oil has a high VI, it means there is minimal change in the viscosity of the oil with changes in temperature. Similarly, oil that is heavily dependent on temperature has a low VI.

For rolling bearing lubrication, SKF recommends using oils with a VI of at least 95.

ISO viscosity grade (VG)

ISO has an established standard about oil viscosity, known as the ISO viscosity grade (VG). It is simply the average oil viscosity at 40 °C (105 °F). As an example, ISO VG 68 oil has an average viscosity of 68 mm²/s at 40 °C (105 °F) (68 cSt).

The minimum and maximum viscosities for each ISO viscosity grade are provided in **Appendix I-2**, on **page 415**. A comparison of the various viscosity classification methods is provided in **Appendix I-1**, on **page 414**.

NOTE: Viscosity is expressed in mm²/s or cSt (identical units).

How to select a suitable oil

Standard mineral oils provide adequate lubrication for most applications that are oil lubricated. Synthetic oils should only be selected if they can be justified, as they are normally much more expensive.

When selecting an oil, it is best to consider all contributing factors. Always gather the relevant

Lubrication

information first, before starting the selection process:

- application
- bearing type and boundary dimensions
- bearing load
- operating and ambient temperatures
- rotational speed
- shaft orientation
- external influences e.g. vibration, oscillation
- contamination details

CAUTION: Be careful not to just substitute oil from one lubricant manufacturer with oil from a different manufacturer. They may not be identical or compatible.

Oil selection process

Accurate oil selection is comprised of three detailed steps. A summary of the selection process is provided below.

1 Select the oil viscosity

Oil is chosen on the basis of the viscosity required to provide sufficient lubrication under the prevailing operating conditions.

NOTE: Low viscosity means low friction, but a thin oil film. High viscosity means a thick oil film, but high friction. There needs to be a balance!

To form an adequate lubricant film between the internal contact surfaces in a bearing, the lubricant must retain a certain minimum viscosity “at normal operating temperature”. The minimum kinematic viscosity ν_1 required for adequate lubrication can be determined using the bearing mean diameter d_m and the rotational speed n (→ **diagram 2**). The effectiveness of a particular lubricant is determined by the viscosity ratio κ , which is the ratio of the actual operating viscosity ν to the minimum kinematic viscosity ν_1 . Suitable viscosity ratios are typically between 1 and 4.

The minimum kinematic viscosity is the viscosity required “at normal operating temperature”. The corresponding viscosity at the internationally standardized reference temperature of 40 °C (105 °F) can then be obtained (→ **diagram 3, page 206**) or calculated. With this information, the minimum ISO VG can be selected.

To determine the minimum ISO VG, follow these steps:

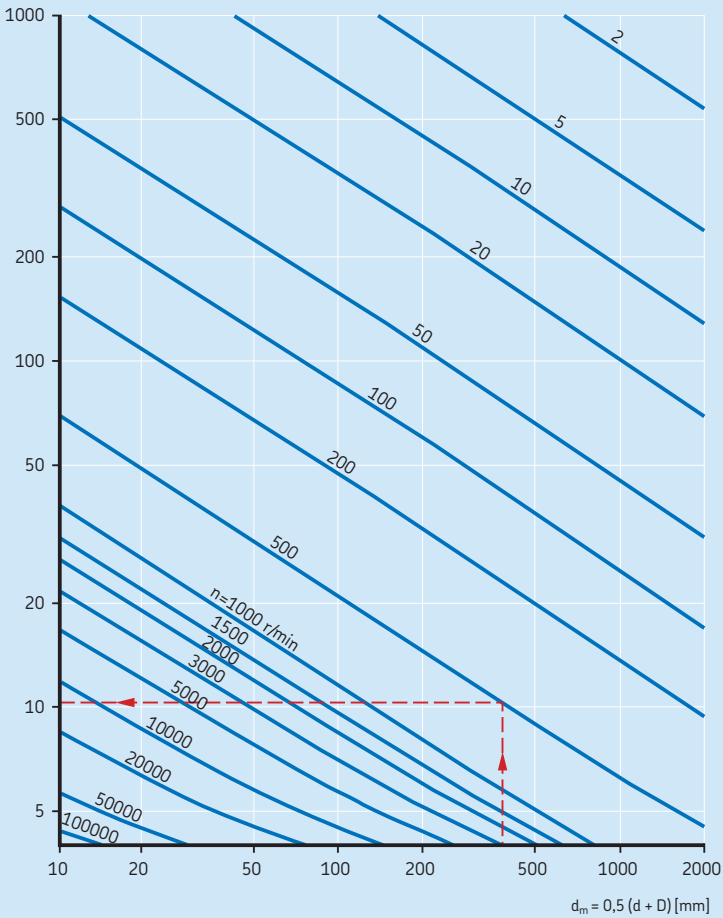
NOTE: When determining the operating temperature of a bearing, keep in mind that the oil temperature is usually 3 to 11 °C (5 to 20 °F) higher than the bearing housing temperature.

- 1 Determine the bearing mean diameter d_m , rotational speed n and expected bearing operating temperature T .
- 2 Using **diagram 2**, locate the point where the mean diameter and rotational speed intersect.
- 3 Read across horizontally to the vertical axis to determine the minimum kinematic viscosity ν_1 at operating temperature.
- 4 Using **diagram 3, page 206**, locate the point where the minimum kinematic viscosity ν_1 at operating temperature, determined in the previous step, intersects the vertical line of the expected bearing operating temperature.
- 5 Locate the first diagonal curve to the right of this point. This is the minimum ISO VG that can be selected.

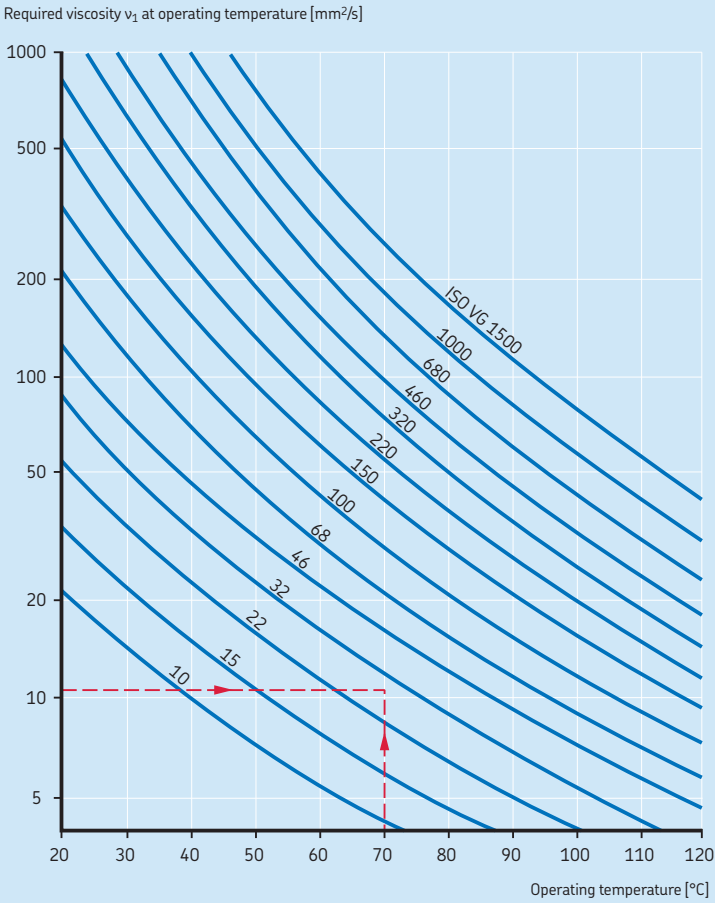
If a lubricant with a higher than required viscosity is selected, an improvement in bearing performance can be expected. However, since increased viscosity raises bearing operating temperature, there needs to be a balance.

Example

A bearing having a bore diameter $d = 340$ mm and outside diameter $D = 420$ mm is required to operate at a speed $n = 500$ r/min. Therefore, $d_m = 0,5 (d + D) = 380$ mm. From **diagram 2**, the minimum kinematic viscosity ν_1 required for adequate lubrication at the operating temperature is approximately 11 mm²/s. From **diagram 3, page 206**, assuming that the operating temperature of the bearing is 70 °C (160 °F), it is found that a lubricating oil of ISO VG 32 viscosity class, i.e. a kinematic viscosity ν of at least 32 mm²/s at the reference temperature of 40 °C (105 °F), will be required.

Estimation of the minimum kinematic viscosity ν_1 at operating temperatureRequired viscosity ν_1 at operating temperature [mm^2/s]

Conversion to kinematic viscosity ν at reference temperature (ISO VG classification)



2 Check anti-wear and extreme pressure additive requirements

Anti-wear (AW) and extreme pressure (EP) additives are required for slow rotating bearings under heavy loads. These additives are also beneficial for shock loads, oscillating applications and when frequent start-ups and shutdowns take place.

CAUTION: Some EP additives may have a detrimental effect on bearing materials and can shorten bearing service life dramatically, particularly above 80 °C (175 °F). Check with the lubricant manufacturer.

3 Assess additional requirements

If specific operating conditions exist, the properties of the oil should complement these conditions accordingly. When bearings have to operate over a wide temperature range, for example, oil with the least changes in temperature variation, i.e. oil with a high VI, should be selected.

Additional oil selection tools

The SKF LubeSelect program can also be used to select an appropriate oil type and viscosity. Another SKF program, LuBase, contains details on more than 2 000 lubricants, provided by more than 100 lubricant suppliers. Both programs are available online at www.apitudexchange.com.

Calculations for minimum oil viscosities can also be made using the formulae, available online at www.skf.com/bearings.

These additional oil selection tools are based on a generalized selection process and should be used as guidelines only.

Oil lubrication systems

Types of oil lubrication systems

The choice of oil lubrication method depends on the application, operating conditions and shaft orientation. The design of the subsequent lubrication system should receive careful consideration. For example, since oils are liquids, suitable sealing solutions must be provided to prevent leakage.

A basic understanding of the design and function of a lubrication system is beneficial for carrying out maintenance activities (→ **table 14, page 208**).

Oil mist lubrication, which is used in very specific applications, is not included in the table.

Maintaining oil lubrication systems

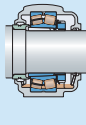
Maintaining an oil lubrication system requires a careful and systematic approach. In addition to the guidelines presented below, SKF recommends taking regular oil samples and trending the results of the analyses.

- For new oil lubrication system installations, make sure that the reservoir, sump or collecting trough is filled with oil to prevent the bearings running without lubrication on start-up.
- When starting a machine with an oil pick-up ring that has been at a standstill for a long time, make sure that the oil sump is filled with oil.
- Inspect the oil at regular intervals for contamination, oxidation or foaming. But keep in mind that the smallest particle size seen by the human eye is 40 µm.
- For an oil-air lubrication system, check the air pressure at the oil inlet hole. It should be about 6 bar.

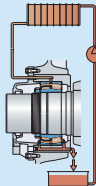
WARNING

Machines that leak oil are dangerous and are a fire hazard. Find the source of the leak and repair it immediately!

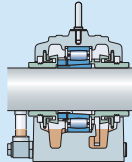
Oil lubrication systems



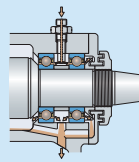
Oil bath



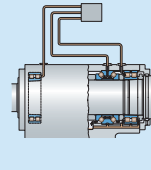
Circulating oil



Oil pick-up ring



Oil jet



Oil-air

Description

Oil, which is picked up by the rotating components of the bearing, is distributed within the bearing and then flows back to the sump.

Oil is pumped to a position above the bearing, runs down through the bearing and settles in the reservoir. The oil is filtered and temperature-adjusted before being returned to the bearing.

The pick-up ring, hanging loosely on a distance sleeve, dips into the oil sump and transports oil to a collecting trough. The oil runs down through the bearing and settles back in the sump.

A jet of oil under high pressure is directed at the side of each bearing.

Metered quantities of oil are directed at each bearing by compressed air. Oil, supplied at given intervals, coats the inside surface of the feed lines and "creeps" toward the nozzles, where it is delivered to the bearings.

Suitable operating conditions

Low and moderate speeds

High speeds

High speeds
High operating temperatures

Very high speeds

Extremely high speeds
Low operating temperatures

Advantages/disadvantages

Simple
Economical

Pump, filters and cooling system required

Suitable for horizontal shafts only

Relatively small amount of oil required

Economical
Helps repel contaminants

Design recommendations

Provide a sight glass for visual checks.

Provide suitable drainage ducts – horizontal drains should be avoided. Make sure the outlet hole is larger than the inlet hole. Include efficient seals.

Provide a sight glass for visual checks. Include effective seals.

Make sure the velocity of the oil jet is at least 15 m/s. Provide suitable drainage ducts – horizontal drains should be avoided.

Oil nozzles must be positioned correctly. Feed lines of up to 10 m can be used. A filter is recommended.

Oil change intervals

The interval between oil changes depends mainly on the oil lubrication system, the operating conditions and the quantity of oil used. For all lubrication methods, oil analysis is recommended to help establish an appropriate oil change schedule.

Guidelines for oil change intervals are provided in **table 15**. In general, the more arduous the conditions, the more frequently the oil should be analyzed and changed.

NOTE: Don't forget to change the filter elements regularly.

Chain oils

Chain lubrication requires a proper lubricant film, especially in the internal parts of the chain. Without suitable lubrication, hastened sprocket wear and chain elongation may occur.

SKF manufactures chain lubricators (→ **fig. 12**) supplied with three different chain oils (→ **table 16**).



Fig. 12

Table 16

SKF Chain oil range

Property	Designation	LHMT 265	LHFP 150
	LHMT 68		
Description	Medium temperature	High temperature	Food compatible
Base oil type	Mineral	Synthetic ester	Synthetic ester
Viscosity / Viscosity Grade	ISO VG 68	265 mm ² /s	ISO VG 150
Operating temperature	-15 to +90 °C (5 to 195 °F)	Up to 250 °C (480 °F)	-30 to +120 °C (-20 to +250 °F)

Table 15

Oil change intervals

Oil lubrication system	Typical operating conditions	Approximate oil change interval ¹⁾
Oil bath or oil pick-up ring	Operating temperature < 50 °C (120 °F) Little risk of contamination	12 months
	Operating temperature 50 to 100 °C (120 to 210 °F) Some contamination	3 to 12 months
	Operating temperature > 100 °C (210 °F) Contaminated environment	3 months
Circulating oil or oil jet	All	Determined by test runs and regular inspection of the oil condition. Dependent on how frequently the total oil quantity is circulated and whether or not the oil is cooled.

¹⁾ More frequent oil changes are needed if the operating conditions are more demanding.

Lubrication

Oil compatibility

Before changing or mixing different types of oil, check that the two oils are compatible. When incompatible oils are mixed, the base oils may have an adverse chemical reaction. Check base oil compatibility provided in **table 11** on **page 201**.

SKF bearings are treated with a petroleum based preservative that is compatible with the majority of bearing oils.

CAUTION: Keep in mind that even if the base oils are compatible, additives from the old oil may alter the performance of those in the new oil. For additional information, contact the lubricant manufacturer.

Oil analysis

Oil analysis is an important part of lubrication maintenance. Samples should be taken at regular intervals and analyzed carefully as soon as possible after drawing the sample. Trending is also essential for proactive maintenance.

In addition to analyzing used oils, SKF recommends analyzing new oils. Often, there is a high particle count in new oil drums as a result of the different handlers and environmental changes experienced from manufacturer to customer.

NOTE: Keep in mind that new oil affects trending!

Oil sampling

An oil sample should be representative of the true condition of the oil. SKF recommends following these guidelines when taking oil samples:

- 1 Use a small, clean container that can be properly sealed.
- 2 Take samples at the pressurized side of a circulating oil system. This can be done via a simple ball valve.
- 3 Take samples from non-pressurized systems, e.g. oil baths, via the outlet hole, allowing some oil to drain out first.
- 4 Seal the container immediately after drawing the sample to prevent the ingress of contaminants.

Oil samples are typically analysed for:

- viscosity
- oxidation
- wear particle concentration
- water content
- loss of additive content

The viscosity of an oil should typically be within 10% of the baseline value. Wear particle concentration and water content are measured in parts per million (ppm). Water content should be < 200 ppm.

Crackle test

The crackle test is a simple way to detect the presence of free water in an oil sample:

- 1 Heat a hot plate to approximately 130 °C (265 °F).
- 2 Shake the oil sample vigorously.
- 3 Place a drop of oil in the centre of the hot plate.

If water is present, vapour bubbles will appear. If crackling can be heard, the water content is likely to be in excess of 2 000 ppm.

NOTE: This test does not detect water dissolved in the oil and should be used as a guideline only. SKF recommends sending the samples in for analysis.

Contamination and filtering

Contaminants, which are unwanted substances that negatively impact the performance of the lubricant, can be solid, liquid or gaseous. Contamination can result from an inadequately sealed application or lubrication system, an inadequate or poorly functioning filtration system, contaminated filling points or wear particles generated by the application.

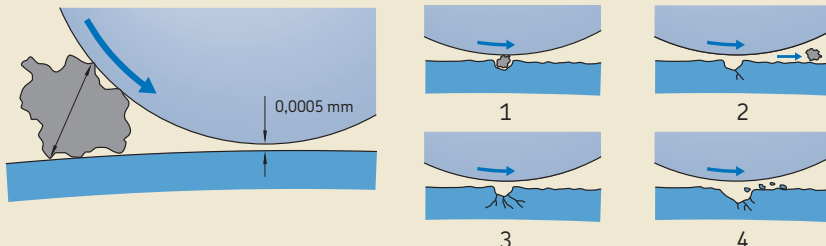
Solid contaminants

Solid contaminants are either created within the application as a result of wear or damage, or they can enter the application through an open port, inadequate or faulty sealing system or, more likely, as a result of poor relubrication practices.

The ingress of solid contaminants into the bearing cavity (→ **fig. 13**) will cause indentations in the raceways as a result of being over-rolled by the rolling elements (**1**). Raised edges will form around the indentation due to plastic deformation (**2**). As the rolling elements continue to over-roll the raised edges, and lubrication is impaired, fatigue occurs (**3**). When fatigue reaches a certain level, premature spalling starts at the far end of the indentation (**4**).

NOTE: Lubricant cleanliness and careful handling during mounting are important factors in the prevention of indentations. Keep in mind that even small pieces of paper or threads from cotton rag can be harmful to a bearing.

Fig. 13



Lubrication

The standard method for classifying the contamination level in a lubrication system is described in ISO 4406:1999. In this classification system, the result of a solid particle count is converted into a code using a scale number (→ **table 17**). There are two methods for checking the contamination level:

- The microscope counting method: With this counting method, two scale numbers are used relating to the number of particles $\geq 5 \mu\text{m}$ and $\geq 15 \mu\text{m}$.
- Automatic particle counting method: With this method, three scale numbers are used relating to the number of particles $\geq 4 \mu\text{m}$, $\geq 6 \mu\text{m}$ and $\geq 14 \mu\text{m}$.

Using the automatic particle counting method, for example, SKF recommends maintaining particle levels at or below a contamination level classification of 18/15/12. This means that the oil contains between 1 300 and 2 500 particles $\geq 4 \mu\text{m}$, between 160 and 320 particles $\geq 6 \mu\text{m}$, and between 20 and 40 particles $\geq 14 \mu\text{m}$. Higher levels are acceptable for bearings with a bore diameter $> 100 \text{ mm}$.

A filter rating is an indication of filter efficiency. The efficiency of filters is related to one specific particle size. Therefore, both the filter rating and the specified particle size have to be considered.

For additional information about contamination classification and filter rating, visit www.skf.com/bearings.

Liquid contaminants

Liquid contaminants include water, fuel, process by-products and chemicals such as glycol. Water extractors should be utilized where water contamination is expected. The type of water extractor depends on the estimated risk of water entering the lubrication system. Where necessary and when economically viable, continuous water removal is recommended.

Gaseous contaminants

Air or gas contamination reduces oil viscosity and increases foaming. Foaming may lead to a loss of oil.

SKF oil lubrication products

SKF offers a wide assortment of products for oil management and maintenance of

Table 17

ISO contamination classification

Number of particles per millilitre oil		Scale number
over	incl.	–
10 000	20 000	21
5 000	10 000	20
2 500	5 000	19
1 300	2 500	18
640	1 300	17
320	640	16
160	320	15
80	160	14
40	80	13
20	40	12
10	20	11
5	10	10

oil lubrication systems (→ **Appendix L**, starting on **page 420**). For additional information, visit www.mapro.skf.com and www.skf.com/lubrication.

Centralized lubrication systems

Centralized lubrication systems feed lubricant from a central reservoir to the points on a machine where friction occurs. The lubricant is supplied as often as necessary and in the correct quantity. Oil and grease with NLGI grades up to 2 can normally be used. Since pumpability is one of the deciding factors, greases with low NLGI grades are often used.

NOTE: Maintenance for centralized lubrication systems is typically limited to refilling the lubricant reservoir and occasionally inspecting the connection points for oil leaks. However, always follow the maintenance instructions supplied with the equipment.

Selecting the appropriate lubricant

Many malfunctions in centralized lubrication systems can be attributed to the wrong choice of lubricant. Lubricants used in centralized lubrication systems should meet the following criteria:

- be free of solid particles capable of passing through a filter with a mesh of 25 µm
- be free of air in the form of bubbles (undissolved gases) to prevent pressure build-up and uncontrolled behaviour of the lubrication system
- be compatible with materials of all components in the bearing arrangements, e.g. seals
- have good oxidation resistance, i.e. good ageing stability
- have a suitable oil bleeding rate, as excessive bleeding leads to pressure losses and blocked systems
- remain homogenous and retain an even consistency at all envisaged operating temperatures
- be free of solid additives that may cause deposit build-up in the pump, valves and distributors

When choosing between a grease and oil lubrication system, technical and economic considerations are decisive. The two types of centralized lubrication systems are compared in **table 18, page 214**. SKF recommends using oil, where possible, but especially for applications such as machine tools, wood-processing, printing and plastic processing machines.

Types of centralized lubrication systems

In technical terms, centralized lubrication systems are divided into total loss and circulating lubrication systems, depending on whether the lubricant is reused or not.

Centralized lubrication systems are in turn categorized by how the system works (→ **table 19, page 215**). Selecting the appropriate system depends on:

- the operating conditions, e.g. operating temperature, viscosity, presence of salt in the atmosphere
- the accuracy requirement of the lubricant quantity
- the geometry and size of the lubrication system
- the monitoring requirements

SKF offers comprehensive and state-of-the-art lubrication systems and integrated solutions that combine SKF's tribology knowledge – the combination of friction, wear and lubrication sciences – and experience in bearings, seals and condition monitoring.

For additional information about SKF Centralized Lubrication Systems, visit www.skf.com/lubrication. For technical support about specific requirements, contact your local SKF representative.

Lubrication

Total loss lubrication systems

In total loss lubrication systems:

- There is no reuse of lubricant.
- Friction points are supplied with fresh lubricant during the lubrication cycle.
- The quantity of lubricant delivered is the amount needed to build up an adequate lubricant film.
- There is no heat dissipation.

Most applications with centralized lubrication systems deal with the lubrication of moving parts, e.g. bearings and gears.

Minimal quantity lubrication (MQL) is a special form of total loss lubrication. These systems deal with the lubrication of machining processes, spraying or wetting of surfaces. With minimal quantity lubrication, it is possible to achieve effective lubrication with extremely small quantities of oil from an aerosol.

Circulating lubrication systems

In circulating lubrication systems:

- There is reuse of lubricant, i.e. the oil flows back into the lubricant reservoir for reuse after being filtered and temperature-adjusted.
- Friction and process-related heat are dissipated.
- Vibrations are dampened.
- Abrasive particles, condensate and process water are removed.
- Air bubbles are removed and foam is reduced.
- Corrosion is prevented.

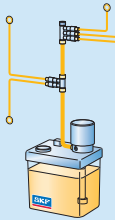
Table 18

Comparison of centralized grease and oil lubrication systems

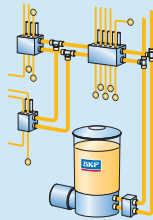
Selection criteria	Advantages/disadvantages	
	Grease	Oil
Operating pressures	50 to 400 bar	14 bar
Tubing and fitting requirements	Large diameter tubing (as a result of excessive pressure loss)	Small diameter tubing
Pump power requirements	Relatively high power	Low power
Contamination	Contaminants remain in suspension and can make their way to the friction area	Contaminants settle at the bottom of the reservoir
Maintenance	Measuring the grease level in the reservoir is complicated Not easy to top up the grease	Easy to measure the oil level in the reservoir Easy to top up the oil
Option for circulating lubricant	Not possible	Relatively easy to achieve
Sealing	Bearings do not need to be sealed Lubricant has a sealing function	Bearing arrangement needs to be sealed to prevent oil leakage and contaminating the surroundings Lubricant offers no protection to contaminants
Cooling and flushing possibilities	None	Yes

Table 19

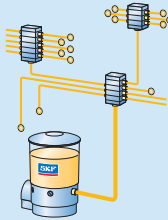
SKF Centralized Lubrication Systems



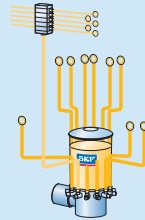
SKF Monoflex



SKF Duoflex

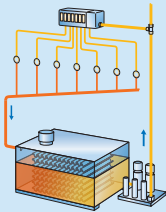


SKF ProFlex

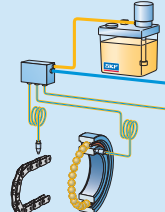


SKF Multiflex

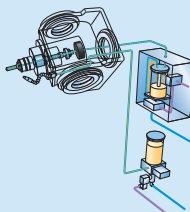
Type	Single-line	Dual-line	Progressive	Multi-line
Suitable lubricants	Oil Grease with NLGI grades from 000 to 2	Oil Grease with NLGI grades from 000 to 3	Oil Grease with NLGI grades from 000 to 2	Oil Grease with NLGI grades from 000 to 3
Application examples	Machine tools, printing, textile and off-highway applications	Metal working machines, pulp and paper industry, mining and cement plants, deck cranes, power plants	Printing and industrial presses machines, off-highway applications, wind turbines	Oil and gas industry, heavy industrial applications



SKF CircOil



SKF Oil+Air



SKF LubriLean

Type	Circulating oil	Oil and air	Minimal quantity lubrication (MQL)
Suitable lubricants	Oil	Oil	Oil
Application examples	Pulp and paper industry, metal working machines, heavy industrial applications	Machine tools, chain applications, steel industry	Machine tools





Inspection

Introduction	218
Maintenance methodologies	218
Inspection during operation	220
Monitoring noise	221
Monitoring temperature	221
Monitoring lubrication conditions	222
Vibration monitoring for rolling bearings.	222
Taking vibration measurements	223
Rolling bearing defect frequency analysis	224
Inspection during a machine shutdown	224
Inspecting the bearings	225
Inspecting the seal counterfaces	226

Introduction

Of the bearings that fail prematurely, many do so because they are subjected to unexpected loads in service such as imbalance or misalignment. Bearing condition is of prime importance when monitoring equipment health. A catastrophic bearing failure causes damage to associated components and may ultimately lead to machine failure.

The approach to bearing and machine maintenance typically follows one of three maintenance methodologies: reactive, preventive or predictive. There are advantages and disadvantages to each, but in general, a proactive approach, combining the best of the methodologies, is recommended.

Condition monitoring is a collective term covering any machine monitoring with instrumentation. Multi-parameter condition monitoring is the most practised technique, with vibration monitoring being the most widely used method of monitoring the condition of a machine. The advantage of using a multi-parameter approach is that it allows the monitoring system to not only consider the bearings, but to look beyond the bearings and consider the whole machine. This provides the opportunity to protect the bearings by correcting underlying machinery faults at an early stage of development.

Bearings and related machinery can be inspected during machine operation or shut-down, depending on the nature of the activity. The wide range of inspection activities are made possible by a large number of available advanced instruments.

Maintenance methodologies

Experience shows that maintenance strategies vary considerably from plant to plant. However, the methodologies employed in implementation of all strategies can be generally classified under a number of common headings (→ **diagram 1**).

Reactive maintenance reflects an absence of an organized maintenance strategy but can, in some situations, be the only suitable maintenance approach. The nature of reactive activities is that

For additional information about SKF condition monitoring, visit www.skf.com/cm or www.apitudexchange.com.

For additional information about SKF condition monitoring instruments and SKF maintenance products, visit www.skf.com/cm and www.mapro.skf.com.

The SKF Reliability Maintenance Institute (RMI) offers a comprehensive range of training courses covering topics such as vibration analysis and thermography (→ *Training*, starting on **page 326**). Contact your local SKF representative for additional information, or visit www.skf.com/services.

they cannot be scheduled in advance. They can, however, be planned in advance to minimize disruption to any scheduled activities.

Preventive maintenance is a routine or scheduled process based on preventing unexpected malfunctions from occurring, by employing proper maintenance procedures and good maintenance practices. An understanding of machinery damage patterns and a maintenance strategy that specifically addresses these damage patterns have a profoundly positive effect on maintenance and operational performance.

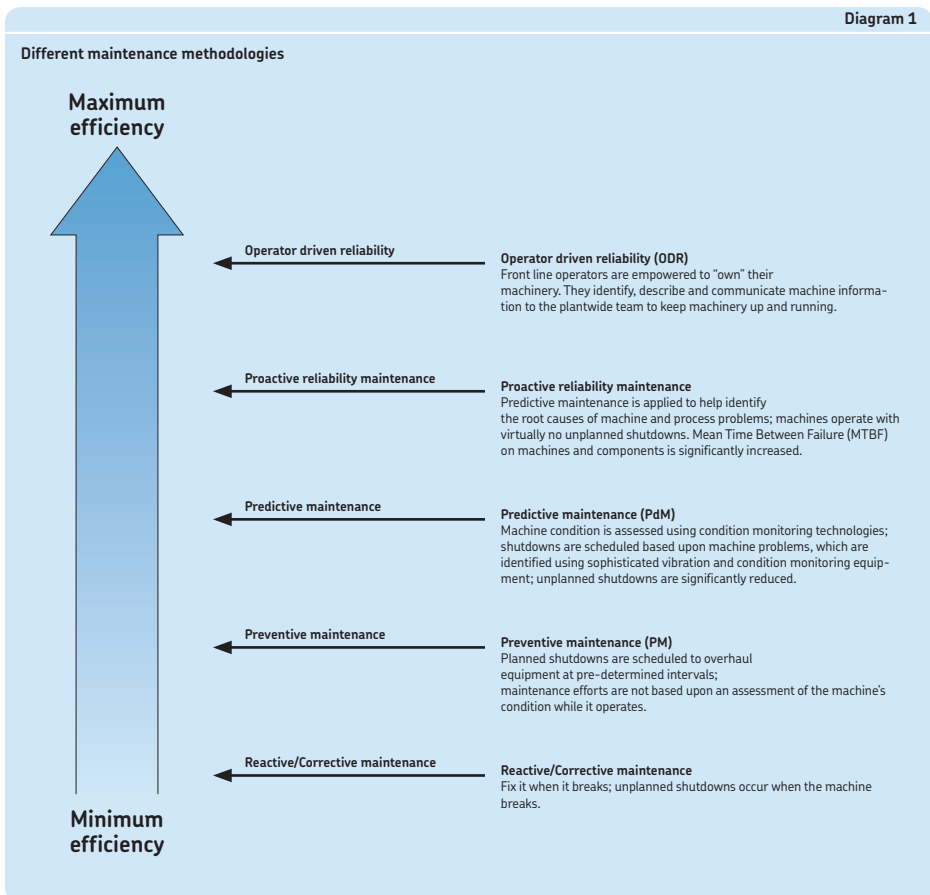
Predictive maintenance (PdM) may be defined as a maintenance process based on machinery inspection, monitoring, and prediction. Machine condition monitoring comprises various instruments and techniques such as vibration monitoring.

It is evident that none of the previously mentioned maintenance methodologies individually provide the ultimate maintenance solution. The real solution lies in a combination of these methodologies.

Proactive reliability maintenance is a structured and dynamic process for applying the appropriate blend of reactive, preventive and predictive maintenance methodologies.

For maximum efficiency, SKF recommends adopting a methodology that promotes the communication of machine information across the plant, driven by operator involvement and commitment.

Diagram 1



Inspection during operation

Bearings are a vital component in any machine with rotating parts and should be monitored closely. Early indications of bearing damage allow bearings to be replaced during regularly scheduled maintenance, avoiding otherwise costly unscheduled machine downtime due to bearing failure.

NOTE: Bearings in critical machinery or in harsh environments should be monitored more frequently!

Various instruments and methods exist for monitoring the performance of bearings and related machine components during operation. Important parameters for measuring machine condition to achieve optimum bearing performance include noise, temperature and vibration.

Bearings that are worn or damaged usually exhibit identifiable symptoms. Many possible causes could be responsible and need to be investigated (→ *Troubleshooting*, starting on page 228).

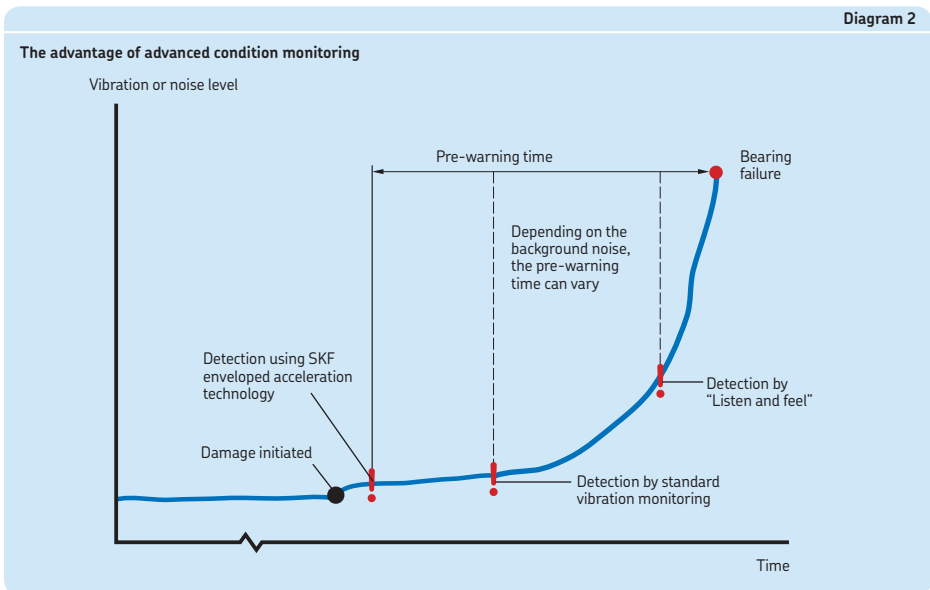
For practical reasons, not all machines or machine functions can be monitored using advanced systems. In these cases, trouble signs can be observed by looking at or listening to the

machine. Using the human senses to detect machinery problems, however, has limited benefit. By the time sufficient deterioration has occurred for the change to be detectable, the damage may already be extensive. The advantage of employing objective technologies, such as vibration analysis, is that faults are detected at an early stage of development, before they become problematic (→ **diagram 2**).

For accurate measurements and reliable results, SKF recommends using professional condition monitoring instruments. For an overview of the basic condition monitoring instruments supplied by SKF, refer to **Appendix N** starting on page 432. For detailed information about these and related products, visit www.skf.com/cm and www.mapro.skf.com.

CAUTION: Don't confuse detection with analysis. Replacing a damaged bearing after detecting high levels of vibration only temporarily solves the problem! The root cause of the vibration should be found, analyzed and addressed.

Diagram 2



Monitoring noise

A common way to identify an irregularity in bearing performance is by listening. Bearings that are in good condition produce a soft purring noise. Grinding, squeaking and other irregular sounds usually indicate that the bearings are in poor condition, or that something is wrong.

The broad range of sounds produced by machines also includes ultrasonic short-wave components that are extremely directional in nature. Instruments, such as ultrasonic probes, isolate these airborne ultrasounds from the background plant and machinery noises, and pinpoint the source.

Another popular instrument for identifying troublesome machine parts or damaged bearings is the SKF Electronic stethoscope (→ **fig. 1**), which detects, traces, and diagnoses the source of all kinds of machinery noise.



Fig. 1

Monitoring temperature

It is important to monitor the operating temperature at all bearing positions. If the operating conditions have not been altered, an increase in temperature is often an indication of imminent bearing damage. However, keep in mind that a natural temperature rise lasting one or two days normally occurs immediately after bearing lubrication and each relubrication.

SKF contact thermometers (→ **fig. 2**) and non-contact thermometers can be used to measure temperatures. Non-contact thermometers are especially useful in areas where access is difficult or hazardous.

In addition, SKF Thermal imagers and SKF Thermal Cameras use infrared to 'see' thermal anomalies or 'hot spots' that the human eye cannot. Infrared thermal inspection can reveal potential problems, and pinpoint problem areas without interrupting production.



Fig. 2

NOTE: In applications where the inner ring rotates, the bearing housing is typically 5 °C (9 °F) cooler than the bearing outer ring and 10 °C (18 °F) cooler than the bearing inner ring.

Inspection

Monitoring lubrication conditions

Bearings can only achieve maximum performance levels with adequate lubrication. The lubrication conditions of a bearing should therefore be monitored closely. The condition of the lubricant itself should also be periodically assessed. The best way to do this is to take a few samples (typically from different areas) and have them analyzed. The SKF Grease Test Kit (→ **fig. 3**) is a useful tool to check the grease properties in the field.

In general, lubricant analysis is undertaken for two primary reasons: to assess the condition of the lubricant and to assess the condition of the machine. Monitoring the condition of the oil for example, offers the opportunity to extend the interval between oil changes with subsequent savings in oil consumption and reduced machinery downtime.

SKF recommends the following general guidelines for lubrication-related inspection activities:

- 1 Check the areas surrounding the bearing positions for lubricant leaks.
- 2 Examine all lubricant leaks. Leaks normally result from worn seals, seal defects, damaged seal counterfaces, liquid contamination such as water in the grease, and loose plugs. They can also result from poor connections between mating parts, e.g. between a housing and an end cover, or from the free oil released by grease that has been broken down by churning.

NOTE: Rubber seals are designed to permit a small amount of lubricant leakage to lubricate the seal counterface.

- 3 Keep protective collars and labyrinth seals filled with grease for maximum protection.
- 4 Check that automatic lubricating systems are functioning properly and providing the appropriate amount of lubricant to the bearings.
- 5 Check the lubricant level in sumps and reservoirs, and replenish as necessary.
- 6 Relubricate bearings with grease, where and when applicable (→ *Relubrication*, starting on **page 192**).

For information about lubricant analysis, grease relubrication and oil changes, refer to *Lubrication*, starting on **page 178**.



Fig. 3

Vibration monitoring for rolling bearings

The need for vibration monitoring comes from three fundamental facts:

- All machines vibrate.
- The onset of a mechanical problem is usually accompanied by an increase in vibration levels.
- The nature of the fault can be determined from the vibration characteristics.

Each mechanical problem generates a unique vibration frequency. Therefore, this frequency should be analyzed to help identify the root cause. To capture the vibration frequency, a transducer (a piezoelectric sensor) is strategically placed on the machine. There is a broad range of frequencies that can be generated by various machine faults:

- low frequency range, 0 to 2 kHz
- high frequency range, 2 to 50 kHz
- very high frequency range, > 50 kHz

Low frequency vibrations are caused, for example, by structural resonance, misalignment or mechanical looseness. High and very high frequencies include those generated by damage (defects) in rolling bearings. Therefore, by measuring the amplitude in terms of acceleration, it is possible to gain a very early indication of developing bearing problems.

Taking vibration measurements

Where to take measurements

Vibration measurements, using for example the SKF Machine Condition Advisor (→ **fig. 4**), should be taken in three different directions at each bearing position on a machine (→ **fig. 5**).

Horizontal measurements typically show more vibration than vertical measurements because a machine is usually more flexible in the horizontal plane. Imbalance, for example, produces a radial vibration that is part vertical and part horizontal. Excessive horizontal vibration is often a good indicator of imbalance.

Axial measurements typically show little vibration but if present, often indicate misalignment and/or a bent shaft.

When to take measurements

The best time to take vibration measurements is when the machine is operating under normal conditions, i.e. when the bearings have reached their normal operating temperature and machine speed is within specification. For variable speed machines, measurements should always be taken at the same point in the process cycle.

NOTE: For comparison purposes, the location and type of measurement, as well as the operating conditions, should be identical each time a measurement is taken.



Fig. 4

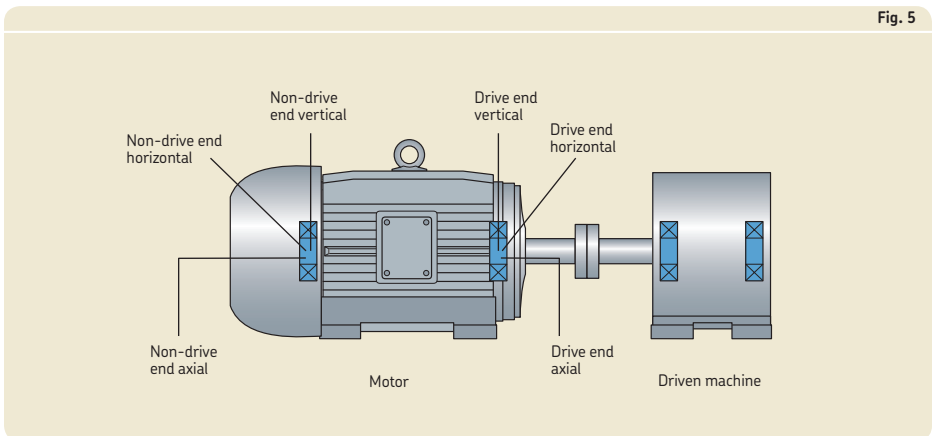


Fig. 5

Inspection

Rolling bearing defect frequency analysis

Every bearing generates a low frequency signal. The frequency of the signal depends on the number and size of the rolling elements, the bearing contact angle and the rolling element pitch diameter.

Every time a bearing defect is over-rolled, a high frequency signal is generated, which causes a peak in the amplitude of the signal. The rate of these peaks is a function of speed as well as the position of the defect on the bearing and the internal geometry of the bearing.

To monitor the condition of a bearing, a technique called enveloped acceleration or enveloping is used. Enveloping isolates the high frequency signal generated by the defect from other naturally occurring rotational or structural frequencies in the machine (→ **diagram 3**).

Calculating bearing defect frequencies

Each bearing component has a unique defect frequency, which enables a specialist to pinpoint damage.

The following defect frequencies can be calculated:

- BPF0, ball/roller pass frequency outer ring raceway(s) [Hz]
- BPF1, ball/roller pass frequency inner ring raceway(s) [Hz]
- BSF, ball/roller spin frequency [Hz]
- FTF, cage frequency (fundamental train frequency) [Hz]

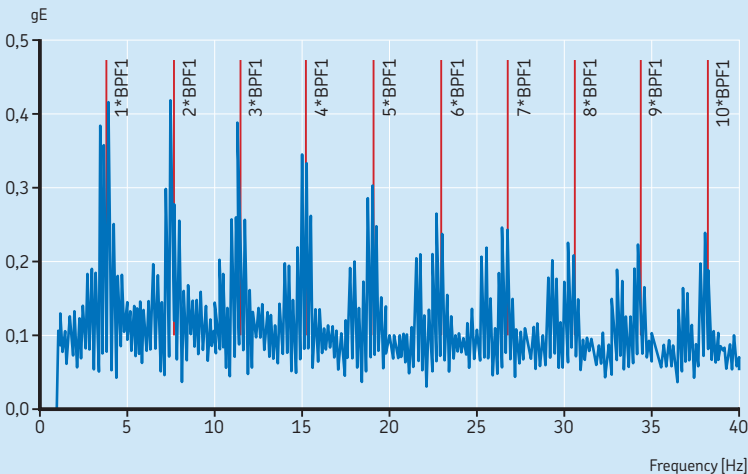
A program to calculate bearing defect frequencies and thereby pinpoint damage is available online at www.skf.com/bearings.

Inspection during a machine shutdown

When a machine is not operating, it is an opportunity to assess the condition of bearings, seals, housings, seal counterfaces and lubricant. A general inspection can often be done by removing a housing cover or cap. For a more detailed inspection, the bearings first need to be

Diagram 3

Enveloped acceleration analysis



cleaned. If a bearing appears to be damaged, it should be dismantled and thoroughly inspected.

Shaft and belt alignment as well as a thorough inspection of the machine foundation and exterior can also be done during a machine shutdown. Any condition, whether it is a missing shim or a deteriorating foundation, can negatively affect machine operation. The sooner any problem is identified, the sooner corrective action can begin.

For additional information about machine alignment, refer to *Alignment*, starting on page 158.

CAUTION: Replace bearings if they are damaged (and where applicable, the associated sleeves, nuts, washers and seals at the same time). Installing new bearings during a regularly scheduled shutdown is far less expensive than doing so during unexpected machine downtime due to a premature bearing failure.

Inspecting the bearings

Bearings are not always easily accessible. However, when bearings are partially exposed, visual checks can be made. The most practical time to inspect bearings is during routine maintenance.

In cases where it is difficult or time consuming to gain access to the bearings for inspection, an SKF Endoscope (→ fig. 6) can be a valuable tool. This particular endoscope, for example, has a small diameter insertion tube, an LCD display and a picture recording function.

When inspecting a mounted bearing, SKF recommends following these general guidelines:

NOTE: Take photographs throughout the inspection process to help document the condition of the bearing, lubricant and machine in general.

Preparation

- 1 Clean the external surface of the machine to prevent dust and dirt from entering the bearing arrangement during inspection.
- 2 Remove the housing cover, or in the case of a split housing, the housing cap, to expose the bearing.
- 3 Remove some lubricant from the housing base, for lubricant analysis.



Fig. 6

WARNING

To minimize the chance of serious injuries, prior to starting any work, perform required lockout/tagout procedures.

- 4 For grease lubricated open bearings, take a few lubricant samples from different areas, for lubricant analysis. Visually inspect the condition of the lubricant. Often, impurities can be detected simply by rubbing some lubricant between the thumb and index finger. Another method is to spread a thin layer on a sheet of paper and examine it under a light.
- 5 Clean the exposed external surfaces of the bearing with a lint-free cloth.

CAUTION: Direct contact with petroleum products may cause allergic reactions. Use SKF protective gloves and safety goggles when handling solvents and cleaning bearings!

Inspection

Inspection

- 1 Inspect the exposed external surfaces of the bearing for fretting corrosion. If fretting corrosion is present but not severe, use fine wet and dry abrasive paper to remove it.
- 2 Inspect the bearing rings for cracks.
- 3 For sealed bearings, inspect the seals for wear.
- 4 Rotate the shaft very slowly and feel for uneven resistance in the bearing. An undamaged bearing turns smoothly.

Where a more detailed inspection of grease lubricated open bearings is required, continue as follows:

- 5 Remove all grease from the housing base.
- 6 Remove as much grease from the bearing as possible using a non-metallic scraper.

NOTE: Keep a representative sample of the grease for further analysis (→ **fig. 7**).

- 7 Clean the bearing with a petroleum based solvent by spraying the solvent into the bearing. Rotate the shaft very slowly while cleaning it and continue to spray until the solvent ceases to collect dirt and grease. For large bearings that contain a build-up of badly oxidized lubricant, clean them with a strong alkaline solution containing up to 10% caustic soda and 1% wetting agent.
- 8 Dry the bearing with a lint-free cloth or clean, moisture-free compressed air.

- 9 Use an endoscope to inspect the bearing raceways, cage(s) and rolling elements for spalls, marks, scratches, streaks, discolouration and mirror-like areas. Where applicable, measure the radial internal clearance of the bearing (to determine if wear has taken place) and confirm that it is within specification.
- 10 If the condition of the bearing is satisfactory, apply the appropriate grease to the bearing immediately and close up the housing. If bearing damage is evident, dismount the bearing (→ *Dismounting*, starting on **page 252**) and protect it from corrosion. Then, conduct a full analysis (→ *Bearing damage and their causes*, starting on **page 288**).

NOTE: Certain large and medium-size bearings are suitable for reconditioning. For additional information, refer to *Remanufacturing and refurbishment*, on **page 331**.

Inspecting the seal counterfaces

To be effective, a seal lip must run on a smooth counterface. If the counterface is worn or damaged, the seal lip will cease to function properly. This is particularly important when installing a new seal. If a new seal is positioned over a worn or damaged counterface, it will either not seal or it will fail prematurely.

Therefore, the seal counterface must be repaired before new seals are installed.

When inspecting the seal counterface, also check for fretting corrosion. If fretting corrosion is evident but not severe, use fine wet and dry abrasive paper to remove it.

Fig. 7



Fresh grease:
brown colour

Used grease:
yellow colour



Fig. 8

NOTE: Shafts and other components that have worn or damaged seal counterfaces do not necessarily have to be replaced. They can be built up and remachined. Where appropriate, an SKF SPEEDI-SLEEVE (for shaft diameters ≤ 203 mm) or a large diameter wear sleeve (LDSL) (for shaft diameters > 203 mm) are an excellent and cost-effective way to repair wear grooves (\rightarrow **fig. 8**). For additional information about SKF wear sleeves, refer to *Repairing a worn shaft with an SKF wear sleeve*, starting on **page 152**.



SKF

TOOL
RELEASE

Troubleshooting

Introduction	230
Why bearings fail	230
Factors influencing bearing service life	230
Troubleshooting	232
Common symptoms of bearing trouble	232
Trouble conditions and their solutions	235

Introduction

Why bearings fail

Only a small fraction of all bearings in use fail (→ **diagram 1**). Most of them (some 90%) out-live the equipment to which they are fitted. A number of bearings (9,5%) are replaced prior to failure for security (preventive) reasons. Approximately 0,5% of bearings are replaced because they are damaged or failed.

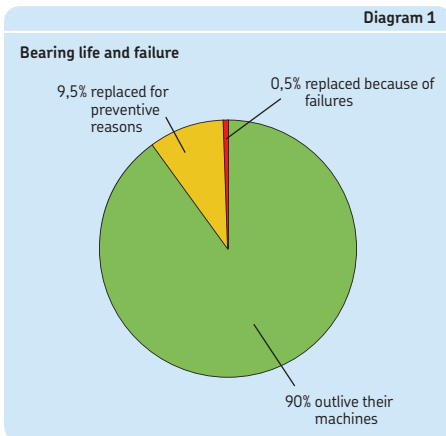
There are several reasons why bearings can be damaged or fail, including:

- fatigue
- ineffective seals
- inadequate lubrication
- heavier loading than anticipated
- wrong or inadequate fits
- incorrect installation

Each of these events produces its own particular damage to the bearing and leaves an imprint, called a pattern (→ *Path patterns*, starting on **page 291**). Consequently, by examining a damaged bearing carefully, it is possible, in the majority of cases, to find the root cause of damage. Based on the findings, corrective actions can be taken to prevent a recurrence of the problem.

Of the bearings that do fail, generally speaking:

- 1/3 fail due to fatigue
- 1/3 fail due to lubrication problems
- 1/6 fail due to contamination



For additional information about SKF condition monitoring instruments and SKF maintenance products, visit www.skf.com/cm and www.mapro.skf.com.

SKF offers a broad range of mechanical maintenance services (→ *Mechanical maintenance services*, **page 330**) and the SKF Reliability Maintenance Institute (RMI) offers a comprehensive range of training courses (→ *Training*, starting on **page 326**). Contact your local SKF representative for additional information, or visit www.skf.com/services.

- 1/6 fail for other reasons (such as improper handling and mounting)

The figures vary, depending on the industrial segment. In the Pulp and Paper industry, for example, a major cause of bearing failure is contamination and inadequate lubrication, not fatigue.

Factors influencing bearing service life

Generally speaking, bearings in an application have a calculated life (→ *Bearing life*, starting on **page 27**). Whether or not bearings reach or exceed that calculated life depends on a number of factors:

- **Bearing quality**
Only bearings manufactured to the highest quality standards can provide long service life.
- **Storage**
Stocking bearings correctly is an important aspect of proper storage. Avoid overstocking and using the “first in, first out” approach will help make sure that “fresh” bearings are on the shelf. This is particularly important for bearings containing seals or shields, as they are lubricated at the factory and the grease has a limited shelf life. Also keep in mind that with rapid changes in manufacturing technology, bearings made today have a much longer built-in life than bearings made 10 or 15 years ago. For additional information about

storing bearings, refer to *Storage of bearings, seals and lubricants*, starting on **page 41**.

- **Application**

The application utilizes the appropriate bearings.

- **Mounting**

Bearings will only function properly if mounted correctly (→ *Mounting rolling bearings*, starting on **page 44**). Improper mounting techniques can easily damage bearings, causing premature failure.

- **Lubrication**

Different operating conditions require different lubricants and relubrication intervals. Therefore, it is important to not only apply the right lubricant, but to also apply the right amount, at the right time, using the right method (→ *Lubrication*, starting on **page 178**).

- **Sealing solution**

The purpose of a seal is to keep lubricants in and contaminants out of the bearing. Premature bearing failure could result if the application is not sealed adequately.

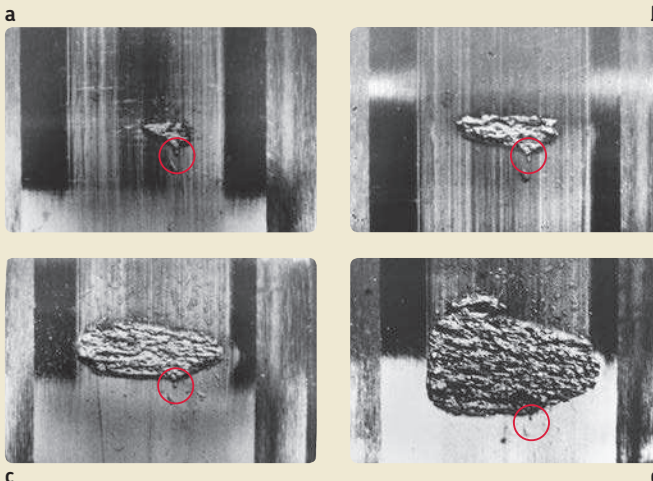
If any one of these factors is weak, bearing service life can be compromised. If they are all strong, long bearing service life can be expected.

For example, take an application with inadequate sealing. When contaminants in the form of particles get into the bearing through the seal, they can be over-rolled by the rolling elements. The over-rolling creates dents in the raceways (→ **fig. 1**). Hard particles may cause dents with sharp corners. When the area around the dents is stressed, surface fatigue is initiated and metal will start to break away from the raceway. This is called spalling. Once spalling has occurred, damage will progress until the bearing becomes unserviceable.

The amount of time from the first (initial) damage until the bearing becomes unserviceable can vary considerably. At higher speeds, it can take a matter of seconds. In large, slow rotating machines, it can take months. The question, "When should I replace the bearing?" is best answered by monitoring the condition of the bearing (→ *Inspection*, starting on **page 216**).

If a damaged bearing goes undiagnosed, and is not replaced before it fails catastrophically, secondary damage to the machine and its components can result. Also, when a bearing fails catastrophically, it can be difficult, even impossible, to determine the root cause of the failure.

Fig. 1



Damage progression

A hard contaminant was over-rolled and made a dent in the raceway (a). The material fatigue started just behind the dent. Over a period of time, spalling becomes more and more important (b, c). If the machine is not stopped in time, secondary damage to machine components might occur. Also, the root cause of the damage might have (completely) disappeared (d).

Troubleshooting

Bearings that are not operating properly usually exhibit identifiable symptoms. The best way to identify these symptoms, and take corrective action at an early stage, is to establish a plant-wide condition monitoring programme (→ *Inspection*, starting on **page 216**).

In cases where condition monitoring equipment is not available or practical, the following section presents some useful hints to help identify the most common symptoms, their causes, and whenever possible, some practical solutions. Depending on the degree of bearing damage, some symptoms may be misleading and, in many cases, are the result of secondary damage. To effectively troubleshoot bearing problems, it is necessary to analyze the symptoms according to those first observed in the application. This is dealt with in more detail in the chapter *Bearing damage and their causes*, starting on **page 288**.

Common symptoms of bearing trouble

Symptoms of bearing trouble can usually be reduced to a few common ones that are listed here. Each symptom is broken down into categories of conditions that can lead to those symptoms (→ **table 1**). Each condition has a numerical code that references practical solutions for that specific condition (→ **table 2**, starting on **page 236**).

NOTE: Troubleshooting information presented in this chapter should be used as a guideline only.

Table 1

Common symptoms of bearing trouble

- | | |
|---|---|
| A | Excessive heat → table 1a |
| B | Excessive noise levels → table 1b |
| C | Excessive vibration levels → table 1c, page 234 |
| D | Excessive shaft movement → table 1d, page 234 |
| E | Excessive frictional moment to rotate the shaft → table 1e, page 235 |

Table 1a

Symptom: A. Excessive heat

Solution code	Possible cause
	Lubrication problem
1	Insufficient lubricant – too little grease, or too low oil level
2	Excessive lubricant – too much grease without the ability to purge or oil level too high
3	Wrong type of lubricant – wrong consistency, wrong viscosity, wrong additives
4	Wrong lubrication system
	Sealing conditions
5	Housing seals too tight, or other components foul the seals
6	Multiple seals in a bearing (housing) arrangement
7	Misalignment of the external (housing) seals
8	Operating speed too high for the contact seals in a bearing
9	Seals not properly lubricated
10	Seals oriented in the wrong direction
	Insufficient clearance in operation
11	Wrong choice of initial bearing internal clearance
12	Shaft material expanding more than bearing steel (e.g. stainless steel)
13	Large temperature difference between the shaft and housing (housing much cooler than the shaft)
14	Excessive drive-up on a tapered seat
15	Excessive out-of-round condition of the shaft or housing – bearing pinched in an oval housing
16	Excessive shaft interference fit or oversized shaft seat diameter
17	Excessive housing interference fit or undersized housing seat diameter
	Improper bearing loading
18	Too heavily loaded bearings as a result of changing application parameters
19	Offset misalignment of two units
20	Angular misalignment of two units
21	Bearing installed backwards
22	Out-of-balance condition
23	Wrong bearing located
24	Excessive thrust loads induced
25	Insufficient load
26	Excessive preload

Table 1b

Symptom: B. Excessive noise levels

Solution code	Possible cause
	Metal-to-metal contact
1	Insufficient lubricant
3	Oil film too thin for the operating conditions
25	Rolling elements sliding (skidding)
	Contamination
27	Dents in raceways and/or rolling elements due to ingress and over-rolling of solid contaminants
28	Solid particles left in the housing from manufacturing or previous bearing failures
29	Liquid contaminants reducing the lubricant viscosity
	Too loose fits
30	Inner ring creeping (turning) on the shaft
31	Outer ring creeping (turning) in the housing
32	Bearing lock nut loose on the shaft or on the bearing sleeve
33	Bearing not clamped securely against mating components
34	Excessive radial/axial internal clearance in the bearing
	Surface damage
1, 2, 3, 4	Wear from ineffective lubrication
25	Smearing damage due to sliding rolling elements
27	Dents in raceways and/or rolling elements due to over-rolling of solid contaminants
35	Dents in raceways and/or rolling elements from impact or shock loading
36	False brinelling marks on raceways and/or rolling elements due to static vibration
37	Spalls in raceways and/or rolling elements due to material fatigue
38	Spalls in raceways and/or rolling elements due to surface initiated damage
39	Static etching on raceways and/or rolling elements due to chemical/liquid contaminants
40	(Micro) Spalls on raceways and/or rolling elements due to moisture or damaging electric current
41	Fluting in raceways and/or rolling elements due to passage of damaging electric current
	Rubbing
7	Housing seals installed incorrectly
32	Adapter or withdrawal sleeve not properly clamped
33	Spacer rings not properly clamped
42	Lock washer tabs bent

Table 1c

Symptom: C. Excessive vibration levels

Solution code	Possible cause
	Metal-to-metal contact
25	Rolling elements sliding (skidding)
	Contamination
27	Dented raceways and/or rolling elements due to ingress and over-rolling of solid contaminants
28	Solid particles left in the housing from manufacturing or previous bearing failures
	Too loose fits
30	Inner ring creeping (turning) on the shaft
31	Outer ring creeping (turning) in the housing
	Surface damage
1, 2, 3, 4	Wear from ineffective lubrication
25	Smearing damage due to sliding rolling elements
27	Dents in raceways and/or rolling elements due to over-rolling of solid contaminants
35	Dents in raceways and/or rolling elements from impact or shock loading
36	False brinelling marks on raceways and/or rolling elements due to static vibration
37	Spalls in raceways and/or rolling elements due to material fatigue
38	Spalls in raceways and/or rolling elements due to surface initiated damage
39	Static etching on raceways and/or rolling elements due to chemical/liquid contaminants
40	(Micro) Spalls on raceways and/or rolling elements due to moisture or damaging electric current
41	Fluting in raceways and/or rolling elements due to passage of damaging electric current

Table 1d

Symptom: D. Excessive shaft movement

Solution code	Possible cause
	Looseness
30	Inner ring loose on the shaft
31	Outer ring excessively loose in the housing
33	Bearing not properly clamped on the shaft or in the housing
	Surface damage
1, 2, 3, 4	Wear from ineffective lubrication
37	Spalls in raceways and/or rolling elements due to fatigue
38	Spalls in raceways and/or rolling elements due to surface initiated damage
	Incorrect internal bearing clearance
11	Bearing with wrong clearance installed
33	Bearing not properly clamped on the shaft or in the housing, excessive endplay

Table 1e

Symptom: E. Excessive frictional moment to rotate the shaft

Solution code	Possible cause
Preloaded bearing	
11	Wrong clearance selected for the replacement bearing
12	Shaft material expanding more than bearing steel (e.g. stainless steel)
13	Large temperature difference between the shaft and housing
14	Excessive drive-up on a tapered seat
15	Excessive out-of-round condition of the shaft or housing – pinched bearing
16, 17	Excessive shaft and/or housing interference fits
26	Excessive preload – incorrect assembly (preload)
Sealing drag	
5	Housing seals too tight, or other components foul the seals
6	Multiple seals in a bearing (housing) arrangement
7	Misalignment of external (housing) seals
9	Seals not properly lubricated
Surface damage	
37	Spalls in raceways and/or rolling elements due to fatigue
38	Spalls in raceways and/or rolling elements due to surface initiated damage
41	Fluting in raceways and/or rolling elements due to passage of damaging electric current
Design	
43	Shaft and/or housing shoulders out-of-square with the bearing seat
44	Shaft shoulder is too large, fouling the seals/shields

Trouble conditions and their solutions

Practical solutions to common symptoms of bearing trouble are provided in **Table 2**, starting on **page 236**.

WARNING

To minimize the chance of serious injuries, prior to starting any work, perform required lockout/tagout procedures.

CAUTION: Direct contact with petroleum products may cause allergic reactions! Read the material safety data sheets before handling lubricants and use protective gloves at all times.

Trouble conditions and their solutions

Solution code

Condition / Practical solutions

1

Insufficient lubricant

Grease lubrication

Considerations during first-fill or start-up:

- The grease should fill 100% of the bearing, and up to the bottom of the shaft in the housing ($\frac{1}{3}$ to $\frac{1}{2}$).
- If the housing cavity alongside the bearing is small, the grease quantity may need to be reduced slightly to avoid overheating from churning.
- → *Lubrication*, starting on **page 178**.

Actions during operation:

- Check for worn or damaged seals or improper seals. (Check for grease leakage.)
- Leakage from incompatibility of greases. (Check for grease leakage.)

Actions during relubrication:

- Make sure the relubrication interval is correct (not too long).
- Make sure the grease reaches the bearing.
- Make sure fresh grease gets into the bearing.

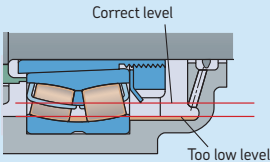
Oil bath lubrication

Consideration during first fill, refill or standstill:

- The oil bath level should be at the middle of the lowest rolling element in a static condition.

Actions during operation:

- Make sure the housing is vented properly to avoid back pressure, which can cause a malfunction of automatic lubricators.
- Check the seals for wear, damage and leaks.
- Check the housing split for leaks and apply a thin layer of gasket cement if necessary.



2

Excessive lubricant

Too much lubricant can cause excessive churning and elevated temperatures.

Grease lubrication

Considerations during first fill or start-up:

- The grease should fill 100% of the bearing, and up to the bottom of the shaft in the housing ($\frac{1}{3}$ to $\frac{1}{2}$).
- If the housing cavity alongside the bearing is small, the grease quantity may need to be reduced slightly to avoid overheating from churning.
- → *Lubrication*, starting on **page 178**.

Actions during operation:

- Check if grease purging is possible, either through the seals or a drain plug. A grease escape valve might avoid applying excessive grease.
- Check the seals for proper orientation, which will enable excess lubricant to purge while keeping contaminants out.
- Make sure the relubrication interval is not too short.
- Make sure to apply the right quantity when relubricating.

Oil bath lubrication

Actions:

- Make sure the oil bath level is set to the middle of the lowest rolling element in a static condition.
- Inspect oil return holes for blockages.
- Installing a sight glass on all housings is a quick, easy way to check whether the oil level in the housings is correct.

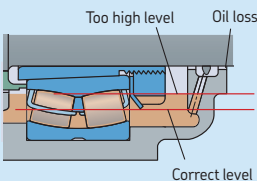


Table 2 cont.

Trouble conditions and their solutions

Solution code

Condition / Practical solutions

3



The wrong lubricant

Actions:

- Review the application to determine the correct base oil viscosity (grease, oil) and consistency (grease) required for the specific operating conditions (→ *Lubrication*, starting on page 178).
- Metal-to-metal contact can lead to excessive heat and premature wear, ultimately leading to higher noise levels.
- Check the miscibility if the grease or oil has been changed from one type to another.
- Check the grease consistency.
- Check the operating viscosity.

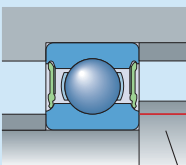
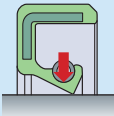
4

The wrong lubrication system

Actions:

- Review the operational speed and measure the operating temperature.
- Determine if a suitable lubricant and lubrication system is used.
- Switching from grease to oil can be a simple solution.
- Switching from oil bath lubrication to circulating oil can be a solution.
- Adding an auxiliary cooler to an existing oil lubrication system can also avoid many heat related problems.
- Consult with SKF or the equipment manufacturer for specific requirements.
- Reference the speed rating values provided in the manufacturer's product guide. SKF values for reference and limiting speeds are available online at www.skf.com/bearings.

5



Correct height

Housing seals are too tight

Actions:

- Check the shaft diameter to make sure it is the correct size for the specific spring-type seal being used to avoid excessive friction or replace the seal with a seal that has the right spring tension.
- Make sure the seals are lubricated properly.
- Check seal lips for wear.
- Felt seals should be soaked in hot oil prior to installation.

Other components foul the bearing seals

Action:

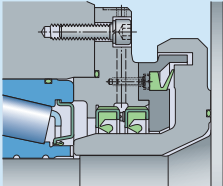
- Check components adjacent to the seals:
 - abutment heights (→ www.skf.com/bearings)
 - possibility to accommodate axial displacement if shaft elongation occurs

Trouble conditions and their solutions

Solution code

Condition / Practical solutions

6

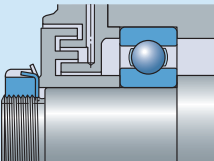


Multiple seals in a bearing (housing) arrangement

Considerations:

- If multiple contact seals are used to help keep contaminants out, friction and heat will increase.
- Before adding additional seals to an application, consider the thermal effects on the bearing and lubricant.
- In addition, consider the extra power required to rotate the equipment.

7



Misalignment of external (housing) seals

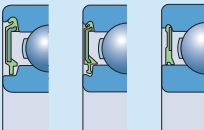
Considerations during assembling:

- Any misalignment of the shaft relative to the housing can cause a non-contact or gap type seal to rub. This condition can elevate temperatures, increase noise levels and accelerate wear during the initial running-in period. It also compromises sealing integrity.

Actions:

- Check the alignment and correct accordingly.
- If misalignment cannot be avoided, there might be a need to increase the clearance or gaps between the external seals.

8



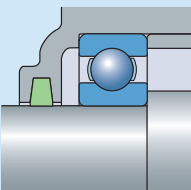
Contact seals

Operating speed too high for contact seals in the bearing

Considerations:

- Seal lips have a limiting speed. If operating speeds exceed these limits, seal lip damage and grease leakage will result.
- If the operating speed has been increased or if a bearing with a different seal is used, check that the bearing seal can accommodate the speed.
- Contact seals will generate more heat than low-friction seals, shields or open bearings.

9



Seals not properly lubricated

Considerations:

- Dry running contact seals can add significant amounts of heat to the system.

Action during assembly:

- Make sure that seals are properly lubricated at start-up of new or rebuilt equipment. (Felt seals should be soaked in hot oil, prior to installation.)

Actions during operation:

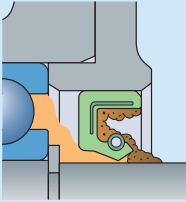
- Normally the lubricant in the housing will get thrown outward towards the seals and automatically lubricate them.
- Properly lubricated seals will run cooler and will create an effective seal since any gaps between the contacts will be filled with a lubricant barrier.
- Proper lubrication will also reduce premature seal wear.
- Check seals for wear or damage.

Trouble conditions and their solutions

Solution code

Condition / Practical solutions

10



Seals oriented in the wrong direction and not allowing grease purge

Consideration during assembly:

- Depending on the application, contact seals may need to be oriented in a specific direction to either allow the lubricant to purge or to prevent oil leakage.

Action:

- Check the application drawings, or contact the equipment manufacturer to determine the proper orientation of the seals for the equipment.

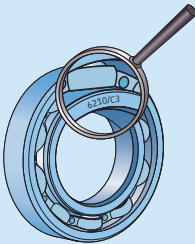
Consideration during operation:

- Seal lips that face outward will usually allow purging of excess lubricant and prevent the ingress of contaminants.

Action:

- Seals must be oriented correctly to keep grease in and contaminants out of the bearing.

11

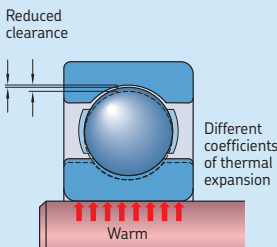


Wrong choice of initial bearing internal clearance

Action:

- Check the package to make sure that the internal clearance of the new bearing is in accordance with the original design specification.
- If a bearing is overheating after it has been replaced, and if larger clearance is required for the application, contact the SKF application engineering service for the effects of additional clearance on the equipment, as well as the bearing.
- Check all dimensions, as component wear can influence bearing clearance.

12



Shaft (and housing) material expands more than bearing steel

Considerations during redesign or remanufacturing:

- In some cases, shaft and housing materials might be changed, e.g. stainless steel shaft to comply with food regulations, or, an aluminium housing to reduce equipment weight.
- When the shaft material has a higher coefficient of thermal expansion than bearing steel, the radial internal clearance is further reduced. Therefore, for certain stainless steel shaft materials (300 series), either a slightly looser shaft fit is required or a bearing with increased radial internal clearance is required, e.g. CN to C3, C3 to C4, etc.
- If a housing made from a material with a higher coefficient of thermal expansion than bearing steel, e.g. aluminium, is used, a slightly tighter fit may be required to prevent the outer ring from turning in the housing seat.

Action:

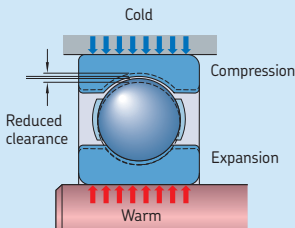
- In both cases it might be necessary to calculate the effect of the new shaft or housing material on internal bearing clearance and replace the bearing accordingly.

Trouble conditions and their solutions

Solution code

Condition / Practical solutions

13



Large temperature difference between the shaft and housing

Considerations during design:

- Due to their design, bearing arrangements often have an inner ring temperature that is higher than the outer ring temperature. For example, the shaft in an electric motor is relatively warm, causing the inner ring to expand. The motor covers that contain the bearing outer rings have a rather large surface area that promotes heat dissipation, making the temperature difference quite substantial.

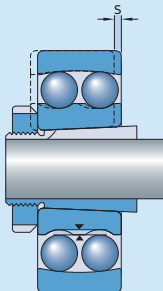
Considerations during operation:

- A large temperature difference between the shaft and housing reduces bearing internal clearance, which can result in too little clearance or even preload, causing high operating temperatures.

Actions:

- Check the shaft and housing temperatures closest to the bearing.
- If justified, select a bearing with increased internal clearance to prevent preloading, e.g. CN to C3, C3 to C4, etc.

14



Excessive drive-up on a tapered seat

Considerations during mounting:

- Mounting a bearing with a tapered bore on a tapered seat (shaft or sleeve) reduces the radial internal clearance within the bearing.

Considerations during operation:

- Too much drive-up "s" may result in too little internal clearance or even preload. This causes higher operating temperatures.
- Excessive drive-up "s" may result in too high hoop stresses in the bearing, resulting in inner ring cracking.

Actions:

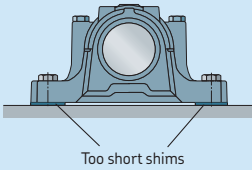
- Small self-aligning ball bearings: After mounting on the shaft, check whether the outer ring can be swivelled easily. If not, dismount the bearing, and start the mounting procedure from the beginning.
- Large self-aligning ball bearings, spherical roller and CARB toroidal roller bearings: Compare the resulting clearance after mounting with the initial bearing clearance. Refer to **Appendix F**, starting on **page 402** for maximum values for clearance reduction. If there is insufficient clearance, dismount the bearing and start the mounting procedure from the beginning.
- For appropriate mounting, use the SKF Drive-up Method or tightening angle method for self-aligning ball bearings, the SKF Drive-up Method or clearance reduction method for spherical roller and CARB toroidal roller bearings. The well-proven SKF Drive-up Method (→ **page 57**) is an easy way to achieve the correct running clearance without using feeler gauges. Use SensorMount (→ **page 67**) for very large bearings.

Trouble conditions and their solutions

Solution code

Condition / Practical solutions

15



Bearing is mounted on/in an out-of-round component

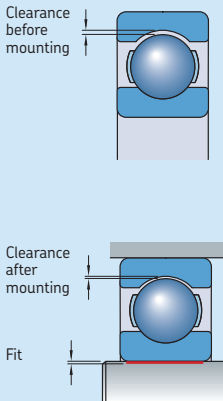
Considerations during operation:

- A bearing outer ring in an out-of-round or distorted housing (oval clamping/pinching) leads to reduced clearance or preload and an increase in operating temperature.
- This is often characterized by two load zones in the outer ring that are 180° apart.
- Oval clamping (pinching) can also restrict axial movement of the non-locating bearing and induce heavy axial loads.

Actions:

- Check that the support surface is flat to avoid soft foot. Any shims should cover the entire area of the housing base.
- Make sure the housing support surface is rigid enough to avoid flexing.
- Check the shaft and housing seats for roundness (ovality) (→ **Appendix D-1, page 386**).
- Re-machine if necessary.

16



Excessive shaft interference fit or oversized shaft seat diameter

Considerations during design:

- An interference fit between the bearing inner ring and shaft seat will expand the inner ring and reduce the bearing internal clearance.
- If the fit is too tight, it may result in too little operating clearance in the bearing, or even preload. This will lead to a hot running bearing.

Actions:

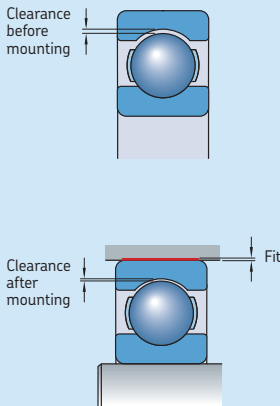
- Check that the installed bearing has the correct internal clearance.
- If the shaft is new or refurbished, carefully check the bearing seat dimensions for both dimensional and form accuracy (→ **Appendix D-1, page 386**).
- Prior to taking any corrective action, check the dimensions of the housing bore.
- If all dimensions are to specification, a bearing with a larger internal clearance might be required.
- Note that an interference fit on the shaft and in the housing will probably result in too little operating clearance (→ *Radial location of bearings*, starting on **page 31**).

Trouble conditions and their solutions

Solution code

Condition / Practical solutions

17



Excessive housing interference fit or undersized housing seat diameter

Considerations during design:

- An interference fit between the bearing outer ring and housing seat will compress the outer ring and reduce the bearing internal clearance.
- If the fit is too tight, it may result in too little operating clearance in the bearing or even preload. This will lead to a hot running bearing.

Actions:

- Check that the installed bearing has the correct internal clearance.
- If the housing is new or refurbished, carefully check the bearing seat dimensions for both dimensional and form accuracy (→ **Appendix D-1, page 386**). Regrind the housing seat to the appropriate fit. If this is not possible, use a bearing with a larger internal clearance.
- Note that an interference fit on the shaft and in the housing will probably result in too little operating clearance (→ *Radial location of bearings*, starting on **page 31**).
- Note that for a rotating inner ring load, an interference fit in the housing will cause the "floating" bearing to become fixed, inducing an axial load and excessive heat.

18

Too heavily loaded bearings as a result of changing application parameters

Considerations during redesign or remanufacturing:

- Increasing the external loads on a bearing will generate more heat within the bearing.
- Heavier loads will reduce bearing service life.
- Therefore, if a design change is made, review the loads to make sure they have not increased.

Examples:

- Going from a coupling to a belt drive.
- Going from a coupling to a sheave.
- Increasing the speed of a piece of equipment.

Action:

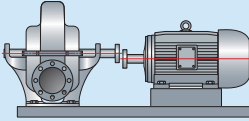
- Changes in the performance of a piece of equipment should be reviewed with the original equipment manufacturer.

Trouble conditions and their solutions

Solution code

Condition / Practical solutions

19



Offset misalignment of two units

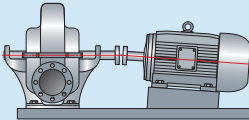
Considerations during assembly:

- The two housings are not in a straight line (vertically or horizontally).
- This induces additional loads on the bearings and seals, which increase friction and temperature and reduce service life of the bearings, seals and lubricant.

Action:

- Align the housings using the appropriate equipment using shims to realign vertically (→ *Alignment*, starting on **page 158**).

20



Angular misalignment of two units

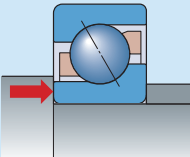
Considerations during assembly:

- The two support surfaces are not aligned: one is angled relative to the other.
- This induces additional loads on the bearings and seals, which increase friction and temperature and reduce service life of the bearings, seals and lubricant.

Action:

- Align the housings using the appropriate equipment and shims (→ *Alignment*, starting on **page 158**).

21



Bearing installed backwards causing unloading of angular contact ball bearings

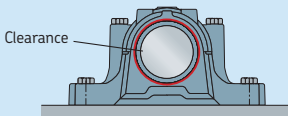
Considerations during assembly:

- Directional bearings must be installed in the right direction to function properly.
- For example: Single row angular contact ball bearings can only accommodate axial loads in one direction. If installed backwards, the axial load will be taken on the low shoulder of the inner ring, which damages the bearing, increases heat generated by the bearing and leads to premature bearing failure.

Action:

- During mounting/assembly, make sure the axial load is accommodated by the "high" shoulder.

22



Out-of-balance condition

Considerations during operation:

- An unbalanced load can generate a rotating outer ring load that will significantly increase the heat generated by the bearing while increasing the load on the bearing.

Actions:

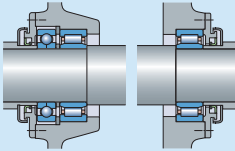
- Inspect the rotor for a build-up of dirt/contaminants.
- Rebalance the equipment.
- Note that too large a housing seat will also cause vibration and outer ring creeping (turning).

Trouble conditions and their solutions

Solution code

Condition / Practical solutions

23



The wrong bearing is (radially) located

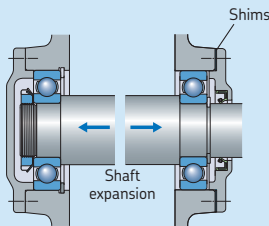
Considerations during design or assembly:

- In some applications, the bearing arrangement for the locating position consists of a radial bearing and a thrust bearing.
- If the radial bearing is fixed axially, it will be subjected to axial loads, resulting in too heavy combined loads. This can lead to excessive temperatures and possibly premature bearing failure.
- If the axial bearing is fixed radially, it will be subjected to radial loads, resulting in (too) heavy combined loads. This can lead to excessive temperatures and possibly premature bearing failure.

Action:

- Make sure that the radial bearing is axially relieved, and the thrust bearing radially relieved. To prevent the outer ring of the thrust bearing from turning, a stop should be provided, e.g. a four-point contact ball bearing generally has locating slots in the outer ring.

24



Bearings are cross-located and the shaft can no longer expand

Considerations during design or assembly:

- When bearings are cross-located and shaft expansion is too restricted, internal axial loads will be induced in both bearings.
- The induced loads can cause excessive operating temperatures and an increased frictional moment.
- The induced loads can be heavy and lead to premature fatigue spalling.

Actions:

- Insert shims between the housing and cover to obtain adequate clearance between the cover and the outer ring side face to avoid axial preloading of the bearings.
- If possible, apply an axial spring load on the outer ring to reduce axial clearance in the bearing system.
- Determining the expected shaft elongation should help establish how much clearance is required between the bearing outer ring side face and the housing cover.

25



Smearing caused when insufficiently loaded rolling elements slide (skid)

Considerations during design:

- In order to provide satisfactory operation and avoid smearing, all ball and roller bearings must always be subjected to a given minimum load (→ www.skf.com/bearings).
- If the minimum load requirements are not met, sliding (skidding) can occur. This generates excessive heat and noise. Extremely stiff greases can contribute to this condition, especially in very cold environments.

Actions:

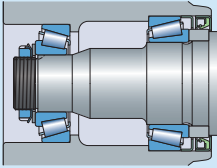
- Additional external loads must be applied, or external spring type devices are required.
- Alternatively, a bearing with different internal clearance or a different bearing type might be required.
- Downsizing the bearing might also be a solution.

Trouble conditions and their solutions

Solution code

Condition / Practical solutions

26



Bearing adjustment results in excessive preload

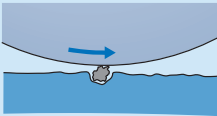
Considerations during mounting or assembly:

- When adjusting the axial clearance or preload in a bearing arrangement, over-tightening the adjustment device (lock nut) can result in excessive preload and excessive operating temperatures.
- Excessive preload will also increase the frictional moment in the bearings. Example: tapered roller bearings or angular contact ball bearings with one bearing on each end of the shaft.

Actions:

- Check with the equipment manufacturer for the proper mounting procedures to set the endplay (axial clearance) or preload in the equipment.
- Use a dial indicator to measure the axial shaft movement (during and) after adjustment.

27



Solid contaminants enter the bearing and dent the rolling surfaces

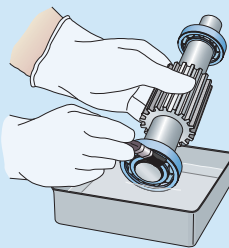
Consideration during operation:

- Contaminants can damage the bearing contact surfaces, increasing noise and vibration levels. In some cases, temperatures may also increase.

Actions:

- Check the sealing arrangement for the following:
 - The correct seal was used.
 - The seal was installed correctly.
 - There is no seal wear, seal damage or lubricant leakage.
- The relubrication interval may need to be shortened. Supplying smaller quantities of fresh grease more frequently can help purge contaminated grease from the bearing/housing cavity (→ *Relubrication*, starting on page 192).
- Consider replacing open bearings with sealed bearings.

28



Solids from manufacturing or previous bearing failures in the housing

Considerations during cleaning or assembly and about lubricant cleanliness:

- Denting of the bearing contact surfaces can occur when solid contaminants are left in the bearing housing from a previous failure, from wear of other components such as gears, or from contaminated lubricant.
- This can increase temperature, noise and vibration levels.

Actions:

- Remove any burrs and make sure that all machined surfaces are smooth.
- Thoroughly clean the housing and all components within the housing before fitting a new bearing.
- Make sure the applied lubricant is clean and does not contain any contaminants. (Grease containers should be closed and stored properly.)

Trouble conditions and their solutions

Solution code

Condition / Practical solutions

29



Liquid contaminants reduce the lubricant viscosity

Considerations during assembly or lubrication and about sealing:

- Liquid contaminants will reduce the lubricant viscosity, which can lead to metal-to-metal contact.
- In addition, it can cause rust to form on the bearing contact surfaces.
- These conditions lead to increased temperature, wear, and noise levels.

Actions:

- Check the housing seals to make sure they can adequately prevent the ingress of liquid contaminants.
- The relubrication interval may need to be shortened. Supplying smaller quantities of fresh grease more frequently can help purge contaminated grease from the bearing/housing cavity (→ *Relubrication*, starting on **page 192**).

30



Inner ring creeps (turns) on the shaft seat

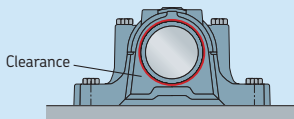
Considerations about fits or creep:

- Most applications have a rotating shaft where the load is uni-directional. This is considered a rotating inner ring load and requires a tight fit on the shaft to prevent relative movement. Proper performance of bearings is highly dependent on correct fits.
- However, an inner ring can creep or turn on its shaft seat if the seat is undersized or worn.
- This leads to increased noise and vibration levels as well as wear.

Action:

- Metalize and regrind the shaft seat to the appropriate size (→ *Radial location of bearings*, starting on **page 31**).

31



Outer ring creeps (turns) in the housing seat

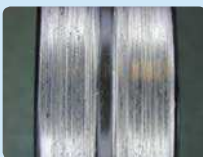
Worn or oversized seat

Considerations about fits or creep:

- Most applications have a stationary housing where the load is uni-directional. This is considered a stationary outer ring load and, under most conditions, the outer ring can be held in place with a loose fit.
- However, an outer ring can creep or turn in its housing seat if the seat is oversized or worn.
- This leads to increased noise and vibration levels as well as wear.

Actions:

- Metalize and regrind the housing seat to the appropriate size (→ *Radial location of bearings*, starting on **page 31**).
- For large housings, machining the seat to a larger diameter and using a cartridge sleeve might be a solution.



Unbalanced load

Considerations about fits or creep:

- Loads resulting from an unbalanced shaft can cause outer ring creep, even if the fits are correct.

Actions:

- Eliminate the source of the unbalance.
- Rebalance the machine.

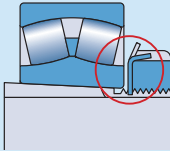
Table 2 cont.

Trouble conditions and their solutions

Solution code

Condition / Practical solutions

32



The bearing lock nut is loose on the shaft or adapter sleeve

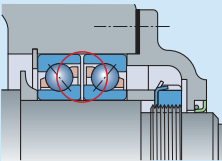
Considerations during mounting or assembly:

- A loose lock nut or lock washer on the shaft or adapter sleeve can cause the bearing to come loose on its seat.
- This can cause the inner ring to creep (turn) on its shaft seat.
- This condition can increase noise levels and heat generated by the bearing, but also leads to poor positioning of the bearing.

Actions:

- Tighten the lock nut to obtain the appropriate position of the inner ring (bearing internal clearance) (→ *Mounting rolling bearings*, starting on page 44).
- Make sure the lock nut is properly locked, with a lock washer tab for example, when mounting is completed.

33



The bearing is not clamped securely against mating components

Considerations during mounting or assembly:

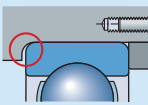
- A bearing that is not properly clamped against an adjacent component might not attain the necessary internal clearance or preload.
- This condition can increase noise levels and have a negative impact on bearing performance.

Examples:

- A pair of matchable angular contact ball bearings that are not properly clamped.
- This can increase axial clearance in the bearing pair, which can lead to ball sliding damage (smearing), increased noise levels, and lubrication problems.
- Not properly clamping the bearing will also affect positioning of the shaft.

Action:

- Make sure that the locking device positions both bearings against their shaft shoulder or spacer.



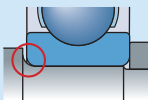
Fillet (corner radius) too large

Considerations during mounting or assembly:

- If the fillet of an adjacent component is too large, the bearing will not be supported properly.
- This condition can distort the bearing rings.
- The bearing will not achieve the proper internal clearance (preload).

Action:

- Machine the fillet to obtain the proper support.

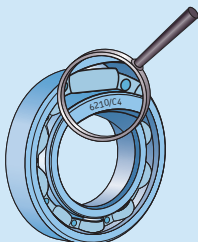


Trouble conditions and their solutions

Solution code

Condition / Practical solutions

34



Too large radial or axial internal clearance in a bearing

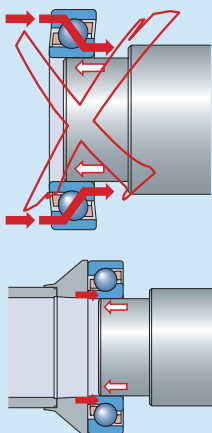
Considerations during operation:

- Excessive radial or axial internal clearance can increase noise levels because the rolling elements are able to move freely outside the load zone.
- In addition, too much clearance can also have a detrimental effect on bearing performance because of sliding of the rolling elements.

Actions:

- The use of springs or wave washers can provide an adequate axial load to keep the rolling elements loaded at all times (mainly in applications with ball bearings).
- Review the needed initial clearance in the bearing; adjust the clearance selection where appropriate.

35



Rolling surfaces are dented from impact or shock loading (incorrect mounting method)

Considerations during design:

- Most bearings are mounted with an interference fit either on the shaft or in the housing.

Considerations during mounting:

- When mounting the bearing ring with an interference fit, always apply force to that ring. Never allow the mounting force to be transmitted through the rolling elements as this can easily dent the raceways and rolling elements.
- The resulting damage can increase noise and vibration levels, and temperature.
- The bearing will probably fail prematurely.

Actions:

- Replace the bearing.
- Never hammer any part of a bearing directly when mounting. Always use a mounting sleeve.
- Review the mounting procedures making sure that no mounting forces are applied through the rolling elements (→ *Cold mounting*, starting on page 53).
- Use a bearing fitting tool. (The SKF Bearing fitting tool kit is an excellent tool for smaller bearings.)

36



Rolling surfaces are false-brinelled due to vibration

Considerations during operation:

- Vibrations from other machines while a piece of equipment is not rotating can lead to false-brinelling on the raceways. This damage typically occurs in the loaded zone, and is characterized by dents that match the distance between the rolling elements.
- This common problem leads to noise in equipment that sits idle for longer periods of time next to other equipment that is operating, i.e. standby equipment.

Actions:

- Periodically rotate the shaft of standby equipment to help minimize the effects of the vibration.
- Isolating the equipment from the vibration would be the real solution but isn't always practical.
- → *Bearing damage and their causes*, starting on page 288.

Table 2 cont.

Trouble conditions and their solutions

Solution code

Condition / Practical solutions

37



Rolling surfaces are spalled due to material fatigue

Considerations during operation:

- Pure material fatigue in a high quality rolling bearing is becoming rare.
- Fatigue spalling is the result of an abnormal operating condition that leads to higher stress in the bearing, such as misalignment, oval clamping (pinching) or the result of material defects such as inclusions or poor quality steel.

Actions:

- Only use high quality bearings.
- Check damaged bearings for misalignment. Realign where necessary.
- Check damaged bearings for possible oval clamping (pinching). Repair and machine seats where necessary.
- → *Bearing damage and their causes*, starting on **page 288**.

38



Rolling surfaces are spalled due to surface initiated fatigue

Considerations during operation:

- Inadequate lubrication leads to metal-to-metal contact between the rolling surfaces.
- Causes include but are not limited to: viscosity too low at operating temperature, wear particles and ingress of contaminants.

Actions:

- Review operating viscosity of the lubricant, taking real operating conditions into consideration.
- To discharge wear particles, consider more frequent relubrication.
- Check the condition of the sealing arrangement.
- → *Bearing damage and their causes*, starting on **page 288**.



Rolling surfaces are spalled, initiated from surface damage

Considerations during mounting or operation:

- Surface initiated damage includes conditions such as brinelling from impact, false brinelling from vibration, water etching, particle denting, passage of electric current, etc.

Actions:

- Identify the source of the damage and take appropriate action, e.g. eliminate impact through the rolling elements during mounting, replace seals to prevent ingress of contaminants, ground equipment properly, etc.
- → *Bearing damage and their causes*, starting on **page 288**.

Trouble conditions and their solutions

Solution code

Condition / Practical solutions

39



Etching of rolling surfaces from chemical/liquid contaminants (water, acids, gasses, or other corrosives)

During standstill:

- Etching (corrosion) occurs when the equipment is idle and is most common in grease lubricated bearings.
- Damage from static etching usually occurs at rolling element distance.

Actions:

- Check the sealing system.
- Upgrade the sealing arrangement by installing a protective shield and/or flinger.
- Supplying smaller quantities of fresh grease more frequently can help purge contaminated grease from the bearing/housing cavity (→ *Relubrication*, starting on **page 192**).
- Periodically rotate the shaft to minimize the damaging effects of static etching.
- → *Bearing damage and their causes*, starting on **page 288**.

40

Raceways and/or rolling elements have (micro) spalls

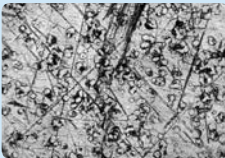
During operation:

- Micro spalls of the rolling surfaces, sometimes called pitting, is the result of either corrosive contaminants or current leakage (electric erosion).
- Whatever the cause, increased noise and vibration levels will result.

Actions:

- → Solution codes **39** and **41**.
- → *Bearing damage and their causes*, starting on **page 288**.

41



Raceways and/or rolling elements have (micro) spalls

During operation:

- Current leakage (electric erosion) – current passing through the bearing – might result in craters at the surface. As they are very small, they can hardly be observed with the naked eye. The SKF Electrical discharge detector pen is a non-contact instrument that can help in establishing the presence of electrical discharge currents.

Actions:

- Magnify area from 500 × to 1 000 × to confirm the presence of craters.
- → *Bearing damage and their causes*, starting on **page 288**.



Fluting of rolling surfaces

During operation:

- Fluting of the raceways is secondary damage most commonly attributed to the passage of damaging electric current across the bearing.
- In some rare cases, a washboard appearance can be the result of vibration during operation.
- Current through the bearing can originate from grounding problems, frequency inverters, cabling, motor design and driven machinery.

Actions:

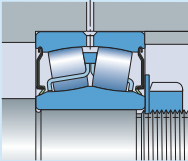
- Check that the equipment is grounded properly.
- If proper grounding does not correct the problem, alternative solutions include INSOCOAT bearings (with an insulation coating), hybrid bearings (with ceramic rolling elements) or using an insulating sleeve in the housing bore.
- → *Bearing damage and their causes*, starting on **page 288**.

Trouble conditions and their solutions

Solution code

Condition / Practical solutions

42



Lock washer tabs are bent, fouling the cage or bearing seals

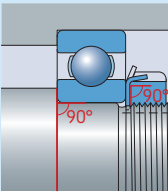
Considerations during mounting or assembly:

- Some lock washers have bent tabs that can foul the bearing cage or seals, generate noise and accelerate wear and damage.
- Used lock washers can also have a damaged locking tab or anti-rotation tab that isn't apparent and may shear off later.

Actions:

- Never reuse washers (and nuts).
- Note that KMFE lock nuts have a built-in spacer to avoid this kind of damage; alternatively, an intermediate ring can be positioned between the bearing and the lock nut.

43



Shaft and/or housing shoulders are out-of-square with the bearing seat

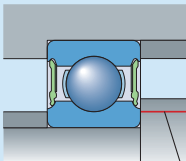
Considerations about machined shoulders during mounting or assembly:

- Out-of-square shaft/housing shoulders can distort the bearing rings, which will increase the frictional moment in the bearing and generate heat.
- → Solution codes **19** and **20**.

Action:

- Machine parts to achieve correct perpendicularity.

44



Correct height

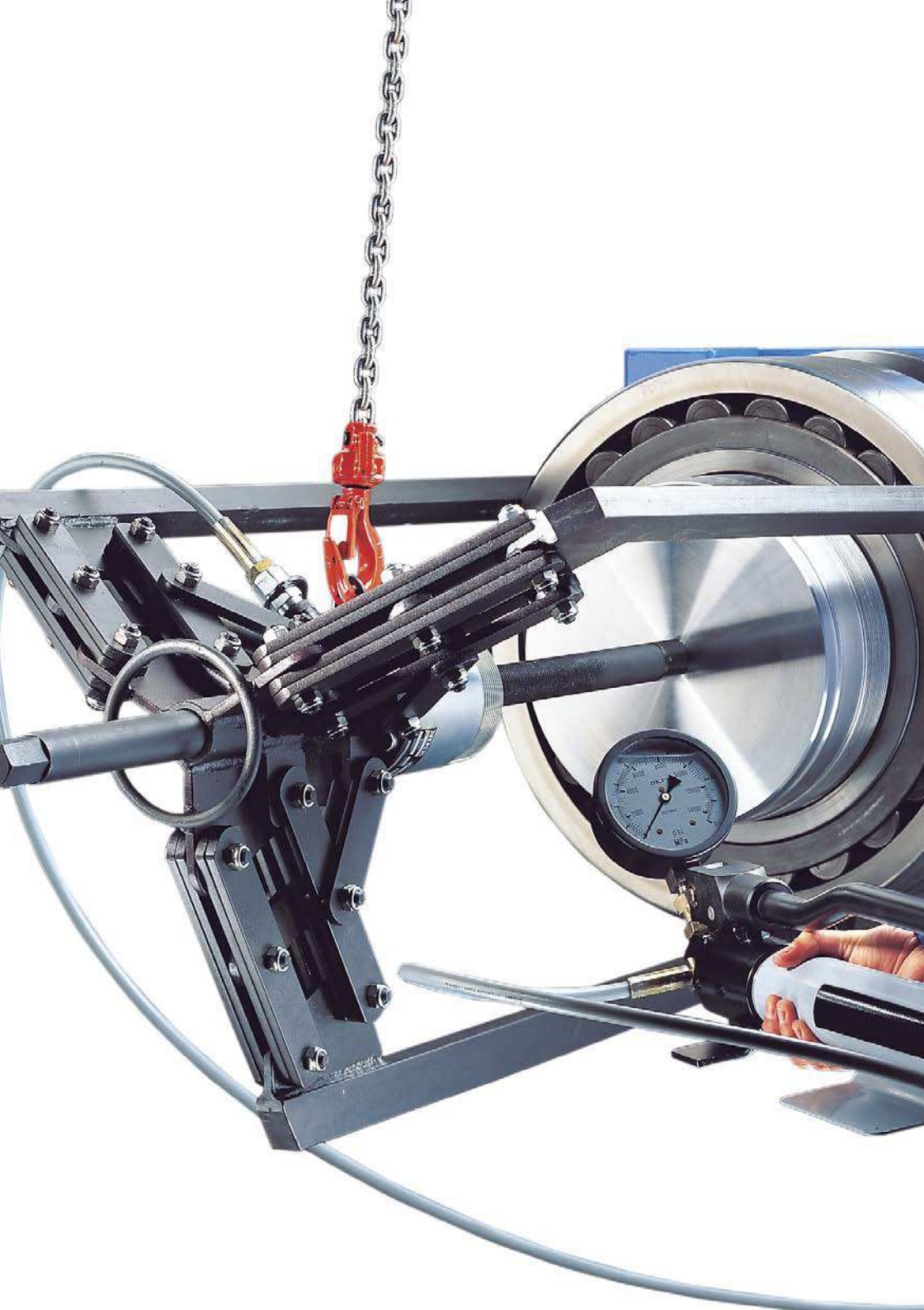
Shaft shoulder is too high and is fouling the seals/shields

Considerations about machined shoulders during assembly or operation:

- If the shoulder is too high, it can foul the seals/shields.

Actions:

- Check that the shoulder diameter is in accordance with recommendations, available online at www.skf.com/bearings.
- Machine the shaft shoulder to clear the seals/shields.



Dismounting

Dismounting rolling bearings	254	Dismounting bearing units	270
What to remember	254	What to remember	270
Preparations prior to dismounting	254	Preparations prior to dismounting	271
Appropriate dismounting methods	255	Dismounting ball bearing units with grub (set) screw locking	272
Dismounting a bearing fitted on a cylindrical shaft seat	256	Dismounting ball bearing units with an eccentric locking collar	273
Manual dismounting	256	Dismounting ball bearing units fitted on an adapter sleeve	274
Dismounting with a hydraulically-assisted puller	257	Dismounting SKF ConCentra ball bearing units	275
Dismounting using the oil injection method	258	Dismounting SKF ConCentra roller bearing units	276
Dismounting with a press	258	Dismounting roller bearing units with a cylindrical locking collar	276
Dismounting with heat	258	Dismounting bearing housings	278
Dismounting a bearing fitted on a tapered shaft seat	259	What to remember	278
Manual dismounting	260	Preparations prior to dismounting	278
Dismounting with a hydraulically-assisted puller	260	Dismounting split plummer (pillow) block housings	280
Dismounting using the oil injection method	260	Dismounting flanged housings	282
Dismounting a bearing fitted on an adapter sleeve	260	Removing seals	284
Manual dismounting: plain shafts	262	Removing non-contact seals	284
Manual dismounting: stepped shafts	262	Removing contact seals	284
Dismounting with a hydraulic nut	262		
Dismounting using the oil injection method	264		
Dismounting a bearing fitted on a withdrawal sleeve	264		
Manual dismounting	264		
Dismounting with a hydraulic nut	266		
Dismounting using the oil injection method	266		
Dismounting a bearing from a solid housing	267		
Manual dismounting	267		
Dismounting using the oil injection method	268		
Dismounting with heat	269		
Dismounting a bearing from a shaft and a solid housing simultaneously	269		

Dismounting rolling bearings

What to remember

When dismounting, there is always the potential to damage an otherwise good bearing. Therefore, whenever possible, do not dismount an undamaged bearing. However, if you must do so and intend to reuse the bearing after dismounting, remember the following:

- Do not hit the bearing rings or any other part directly.
- Never allow the dismounting force to be transmitted through the rolling elements.
- Do not heat the bearing with an open flame.

The tools and methods used to dismount rolling bearings often depend on the size of the bearing. Generally, bearings can be categorized as:

- small bearings: bore diameter $d \leq 80$ mm
- medium-size bearings: bore diameter $80 \text{ mm} < d < 200$ mm
- large bearings: bore diameter $d \geq 200$ mm

After a bearing has been dismounted, wash it with a suitable cleaning solvent and dry it carefully. Inspect all bearing parts, especially the raceways, rolling elements and cage for wear or damage. If the bearing can be reused, protect it against corrosion by coating it thoroughly with either grease, oil or an anti-corrosive fluid, and repackage it.

Small sealed bearings and bearings that are very dirty or encrusted with oxidized lubricant are generally not worth cleaning. Normally, it is more economical to scrap the old bearing and replace it with a new one.

NOTE: Mark the relative position of the bearing in the housing (or on the shaft) (→ **fig. 1**) before the bearing is dismounted. When an undamaged bearing is remounted, the non-rotating ring is typically turned by 120° to 180° to enable a new part of the raceway to be in the load zone.

Dismounting tools and products are available from SKF Maintenance Products (→ **Appendix O**, starting on **page 435**). The SKF Dismounting fluid is suitable for use when dismounting with hydraulically-assisted tools and when using the oil injection method. For additional information, visit www.mapro.skf.com.

The SKF Reliability Maintenance Institute (RMI) offers a comprehensive range of training courses in dismounting techniques (→ *Training*, starting on **page 326**). Contact your local SKF representative for additional information, or visit www.skf.com/services.

Preparations prior to dismounting

Taking the time to prepare can make dismounting easier. If available, review the assembly drawing(s) and study the bearing arrangement. Then, before starting any work, observe the following guidelines:

- Clean the application and the surrounding area thoroughly.
- Have suitable containers on hand to retrieve lubricant samples and collect the used lubricant.
- Have a suitable cleaning solvent available, e.g. petroleum, kerosene or a strong alkaline solution, to clean the shaft, housing, and bearing if it is to be reused.

NOTE: Due to environmental considerations, SKF does not recommend the use of chlorinated solvents of any kind.

Appropriate dismounting methods

SKF recommends using any one of the following methods to dismount bearings:

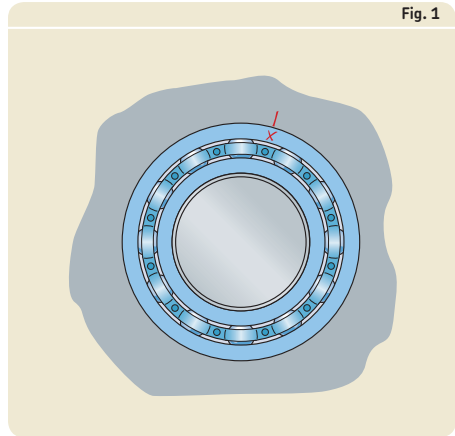
- manual dismounting
- dismounting with hydraulically-assisted tools
- dismounting using the oil injection method
- dismounting with heat

The method used depends largely on the size and type of bearing. Small bearings can be removed from their seats with mechanical tools. Larger bearings generally require greater force than a mechanical tool can provide. Therefore, SKF recommends either hydraulically-assisted tools or the oil injection method, or both.

Heating rings or special induction heaters can be used to remove inner rings of needle roller bearings or NU, NJ and NUP design cylindrical roller bearings. However, using heat to remove other bearing types should only be done as a last resort.

To use the oil injection method, it is presupposed that the necessary oil supply duct and distribution groove have been designed into the bearing arrangement (→ **Appendix G, page 405**).

Fig. 1



Dismounting

Dismounting a bearing fitted on a cylindrical shaft seat

Manual dismounting

Whenever possible, support the shaft in a suitable bench vice (→ **fig. 2**) to avoid damaging the shaft or bearing during the dismounting process.

Small bearings can be removed from the shaft with a mechanical puller. The claws must be applied to the inner ring or an adjacent component, e.g. a labyrinth (→ **fig. 3**).

If it is not possible to apply the claws to the inner ring or a suitable adjacent component, withdraw the bearing via the outer ring. To avoid damage during dismounting, SKF recommends turning the outer ring while the bearing is being dismantled (→ **fig. 4**). However, when this technique is used, SKF does not recommend reusing the bearing.

Fig. 2

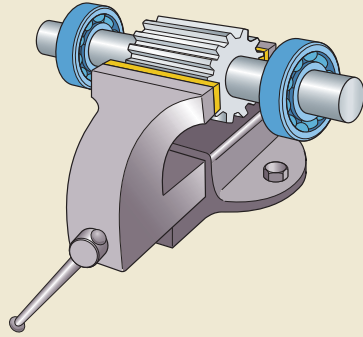


Fig. 3

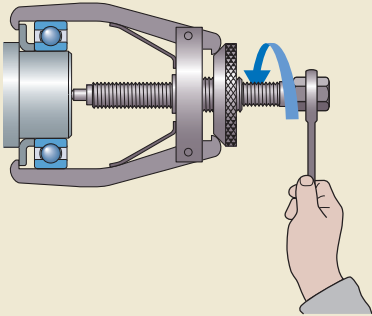
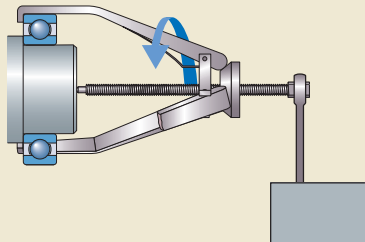


Fig. 4



If a suitable puller is not available, a hammer and a soft metal drift punch or similar tool can be used to drive the bearing from its seat. Light taps with a hammer should be applied evenly around the whole side face of the inner ring (→ **fig. 5**). Be careful when using this technique, because it is very easy to damage the shaft. Also, SKF does not recommend reusing the bearing as undetectable damage may have been done to the bearing during the dismounting process.

Dismounting with a hydraulically-assisted puller

The force to dismount bearings that are mounted with an interference fit on the shaft increases rapidly with the size of the bearing. Therefore, SKF recommends using a hydraulically-assisted heavy-duty puller (→ **fig. 6**) when dismounting large bearings. These pullers are typically available for bearings with an outside diameter up to 500 mm. When using these, follow the instructions supplied with the puller.

SKF also offers hydraulically assisted puller sets that can be used to dismount small and medium-size bearings.

Fig. 5

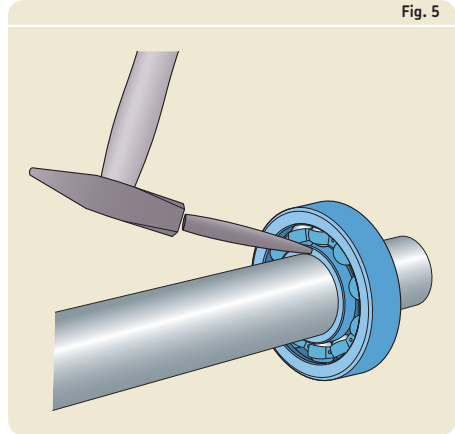
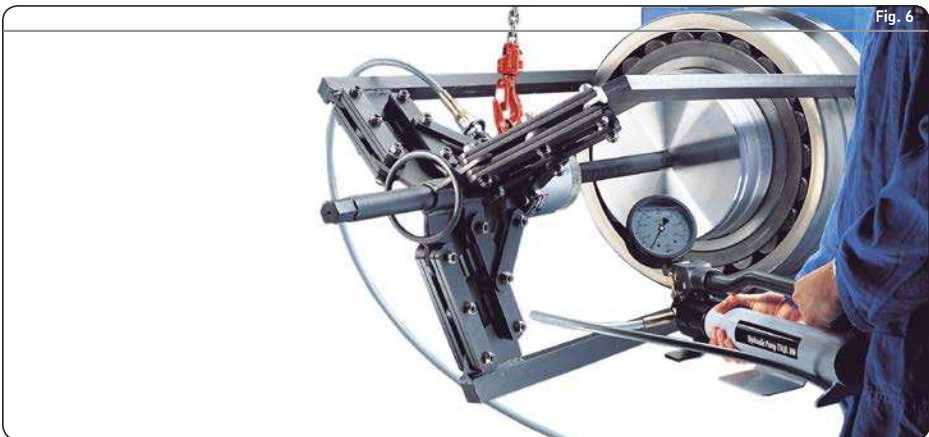


Fig. 6



Dismounting

Dismounting using the oil injection method

The oil injection method can be used to dismount bearings with a cylindrical bore. This method injects oil under high pressure, with a viscosity of about $900 \text{ mm}^2/\text{s}$ at 20°C (70°F), between the shaft seat and the inner ring bore, until an oil film completely separates the contact surfaces (→ **fig. 7**). If the bearing is removed promptly and without interruption, a relatively small force is required for dismounting.

Dismounting with a press

A very convenient way to remove a bearing from its shaft seat is with a press placed against the shaft end. In this case, the bearing inner ring has to be supported (→ **fig. 8**).

Dismounting with heat

Dismounting with heat is a suitable method when removing inner rings of needle roller bearings or NU, NJ and NUP design cylindrical roller bearings. Two different tools for this purpose are common: heating rings and induction heaters.

Heating rings are typically used to mount and dismount the inner ring of small to medium-size bearings that are all the same size.

Heating rings are made of light alloy. They are radially slotted and equipped with insulated handles (→ **fig. 9**). The dismounting procedure is simple. Coat the inner ring raceway of the bearing with an oxidation-resistant oil. Place the heating ring on a hot plate and heat it to approximately 280°C (540°F). Place the heated ring around the inner ring and press the handles together. The heat will transfer rapidly to the inner ring. As soon as the inner ring comes loose, withdraw both the tool and the inner ring. Then, remove the inner ring from the tool.

Fig. 7

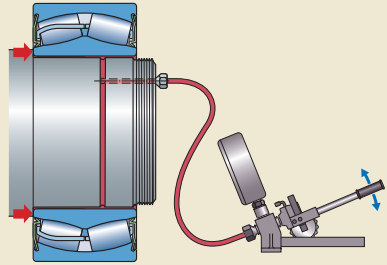


Fig. 8

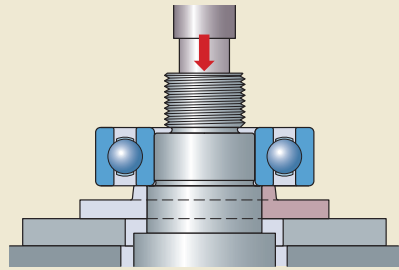
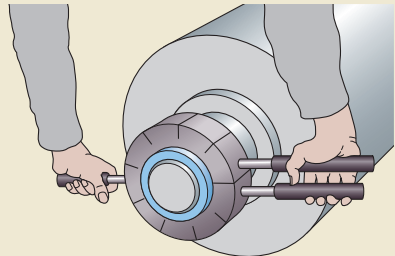


Fig. 9



If inner rings with different diameters are dismounted frequently, SKF recommends using an SKF Adjustable induction heater. These electrical induction heaters (→ **fig. 10**) heat the inner ring rapidly without heating the shaft to any degree. If the inner ring is to be reused, it should be demagnetized after dismounting.

For frequent dismounting of inner rings of medium-size and large cylindrical roller bearings, such as roll neck bearings in rolling mills, SKF recommends using an SKF Fixed induction heater.

Heating rings and induction heaters are available from SKF. For additional information, visit www.mapro.skf.com.

Dismounting a bearing fitted on a tapered shaft seat

To avoid damaging the shaft or bearing during this dismounting process, properly support the shaft. To do this, use a suitable bench vice, two V-blocks (→ **fig. 11**) or lifting tackle.

WARNING

To avoid the risk of serious injury, attach a provision such as a lock nut to the shaft end to limit the bearing travel when it suddenly comes loose.

Fig. 10

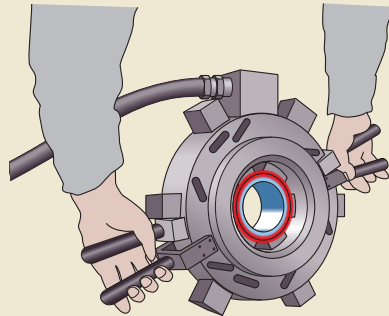
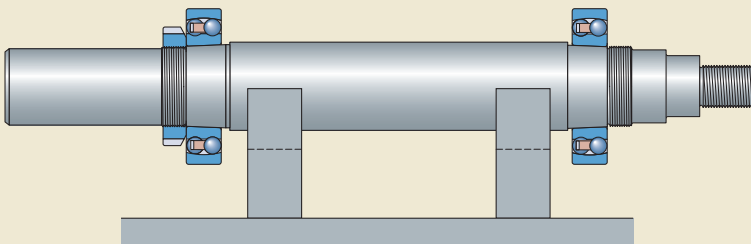


Fig. 11



Dismounting

Manual dismounting

Small bearings can be dismounted using a mechanical puller that engages the inner ring. Self-centring pullers equipped with spring-operated arms should be used to simplify the procedure and avoid damage to the bearing seat.

If it is not possible to apply the claws of the puller to the inner ring, withdraw the bearing via the outer ring or use a puller in combination with a pulling plate (→ fig. 12).

Dismounting with a hydraulically-assisted puller

Larger bearings generally require considerable force and should be removed from their tapered seat with the aid of hydraulically-assisted pullers (→ fig. 6, page 256). These are normally available for bearings with an outside diameter up to 500 mm.

Dismounting using the oil injection method

Dismounting medium-size and large bearings from tapered shafts is easier and much safer when the oil injection method is used. With this method, oil with a viscosity of about $900 \text{ mm}^2/\text{s}$ at $20 \text{ }^\circ\text{C}$ ($70 \text{ }^\circ\text{F}$) is injected under high pressure between the two tapered mating surfaces, via a supply duct and a distribution groove. This significantly reduces the friction between the two surfaces and produces an axial force that separates the bearing from its seat (→ fig. 13).

WARNING

To avoid the risk of serious injury, attach a provision such as a lock nut to the shaft end to limit the bearing travel when it suddenly comes loose.

Dismounting a bearing fitted on an adapter sleeve

The method used to dismount a bearing fitted on an adapter sleeve depends on the following:

- bearing size
- type of arrangement: plain or stepped shaft (→ fig. 14)
- adapter sleeve design: with or without oil supply ducts and distribution grooves for oil injection (→ fig. 15)

In all cases, dismounting starts with the following (→ fig. 16):

- Remove excess lubricant and wipe down the arrangement.

Fig. 12

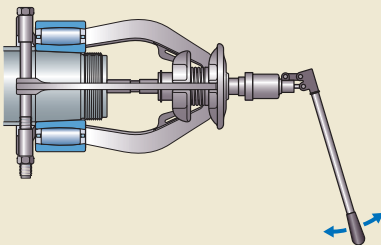


Fig. 13

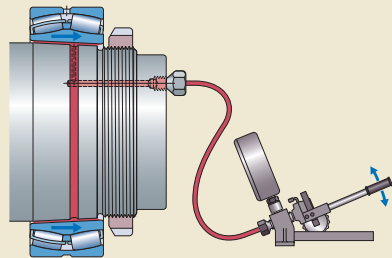


Fig. 14

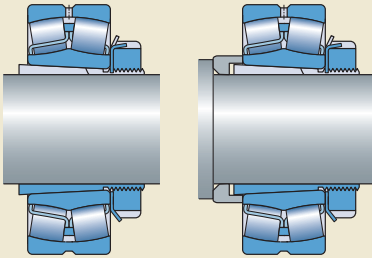
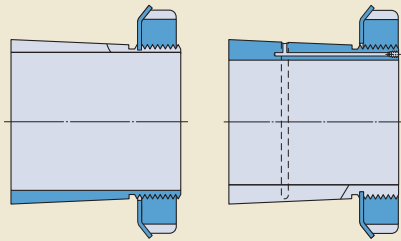
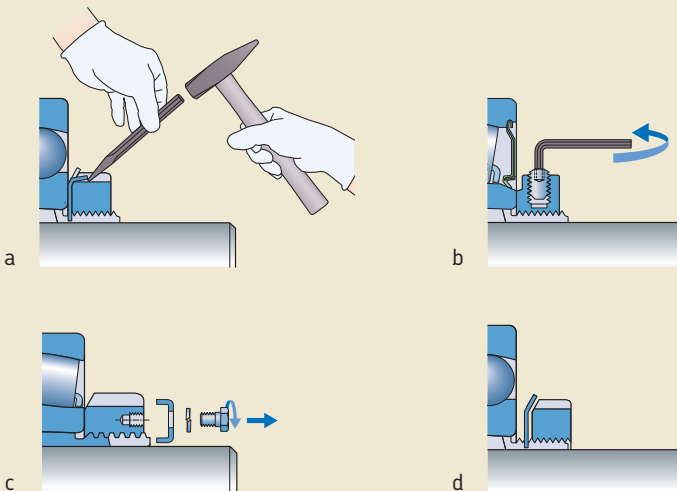


Fig. 15



- Depending on the locking device:
 - Disengage the bent tab of the lock washer from the lock nut (a).
 - Loosen the locking screw in the lock nut (b).
 - Remove the locking clip attached to the lock nut (c).
 - Loosen the lock nut a few turns (d).

Fig. 16



Dismounting

Manual dismounting: plain shafts

Small bearings fitted on an adapter sleeve and a plain shaft can be dismounted by tapping a small steel block with an appropriate hammer, evenly around the bearing inner ring side face (→ **fig. 17**). Before doing so, the sleeve lock nut has to be loosened a few turns. Also, to facilitate reassembly, mark the position of the sleeve on the shaft. After the bearing comes free, completely remove the lock nut, lock washer, bearing and sleeve from the shaft. To facilitate removal, expand the sleeve slightly by inserting a small plastic wedge or screwdriver in the slot of the sleeve.

NOTE: The steel block shown in **fig. 18** is a segment of a turned ring and can be made easily using the dimensions listed in the product tables, available online at www.skf.com/bearings.

Manual dismounting: stepped shafts

Small bearings fitted on an adapter sleeve and a stepped shaft can be dismounted by a couple of sharp hammer blows applied to a mounting dolly abutting the lock nut of the adapter sleeve (→ **fig. 19**). After the bearing comes free, completely remove the lock nut, lock washer as well as the bearing and withdraw the sleeve and the abutment ring from the shaft. To facilitate removal, expand the sleeve slightly by inserting a small plastic wedge or a screwdriver in the slot of the sleeve.

NOTE: Use the SKF Bearing fitting tool kit for shaft diameters ≤ 55 mm (→ **page 72**).

Dismounting with a hydraulic nut

Using a hydraulic nut for dismounting bearings fitted on an adapter sleeve on a stepped shaft makes bearing removal easy. To use this method however, it must be possible to mount a suitable stop for the piston of the hydraulic nut to work against (→ **fig. 20**). The stop can be a washer or a plate bolted to the shaft end or can take the form of a two-piece ring fitted into a groove in the shaft and held in place by a one-piece ring.

Place the hydraulic nut on the adapter sleeve with the piston facing outward. Be sure to leave a gap between the bearing and nut that is greater than the initial axial drive-up distance. Connect the hydraulic pump to the hydraulic nut. When pressurizing the hydraulic nut, the piston

will push the adapter sleeve underneath the abutment ring until the bearing comes free.

To empty the hydraulic nut, open the oil release valve of the hydraulic pump, and push the piston back to its original position by screwing the nut down the threaded portion of the sleeve. Then, disconnect the hydraulic pump and remove the stop. Finally, unscrew the nut from the sleeve and remove both the bearing and sleeve from the shaft.

NOTE: Detailed information about SKF hydraulic nuts is provided under *Hydraulic tools*, starting on **page 73**. Useful instructions can be found under *Oil injection method*, starting on **page 62**.

Fig. 17

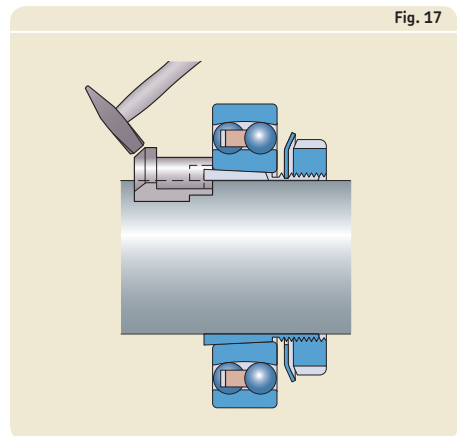


Fig. 18

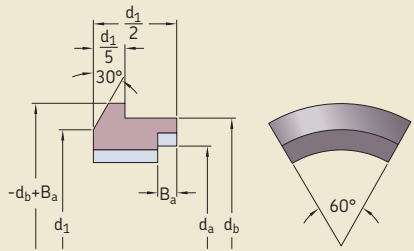


Fig. 19

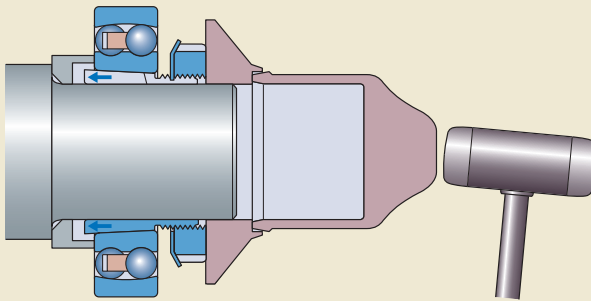
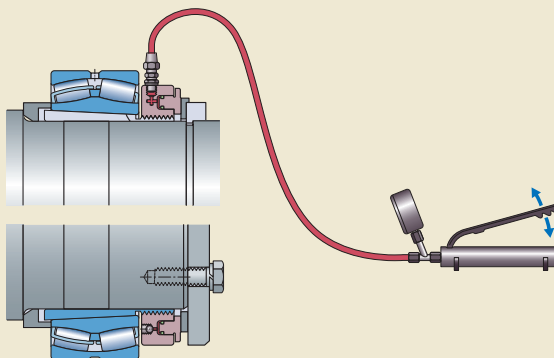


Fig. 20



Dismounting

Dismounting using the oil injection method

Adapter sleeves equipped with an oil supply duct and an oil distribution groove facilitate dismounting because the oil injection method can be used (→ **fig. 21**). This feature is standard for all SKF adapter sleeves with a bore diameter ≥ 200 mm, but can be supplied for sleeves with a bore diameter ≥ 140 mm.

First, disengage the locking mechanism, and loosen the locking screw a few turns. Then, clean the threaded connection hole in the side face of the sleeve. Connect the hydraulic pump via an appropriate extension pipe to the adapter sleeve. Inject oil with a viscosity of about $900 \text{ mm}^2/\text{s}$ at $20 \text{ }^\circ\text{C}$ ($70 \text{ }^\circ\text{F}$) under high pressure between the two tapered mating surfaces via the supply duct and distribution groove in the sleeve. The bearing will dismount suddenly from its seat. After the hydraulic pump and extension pipe have been disconnected, remove the lock nut, lock washer, bearing and adapter sleeve from the shaft.

WARNING

To avoid the risk of serious injury, attach a provision such as a lock nut to the shaft end to limit the bearing travel when it suddenly comes loose.

NOTE: Detailed information about the oil injection method and useful instructions for use can be found under *Oil injection method*, starting on **page 62**.

Dismounting a bearing fitted on a withdrawal sleeve

The method used to dismount a bearing fitted on a withdrawal sleeve depends on the following:

- bearing size
- withdrawal sleeve design: with or without oil supply ducts and distribution grooves for oil injection (→ **fig. 22**)

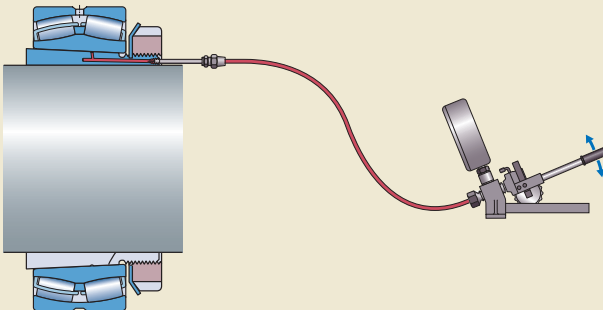
In either case, dismounting starts with the following (→ **fig. 23**):

- Remove excess lubricant and wipe down the arrangement.
- Remove the locking device, e.g. a lock nut and lock washer (**a**) or an end plate (**b**).
- Support the bearing, for example with lifting tackle (**c**).

Manual dismounting

Small and medium-size bearings fitted on a withdrawal sleeve can be dismounted with a lock nut and a hook or impact spanner (→ **fig. 24**). Before screwing the lock nut onto the sleeve thread, lubricate the thread and that part of the lock nut facing the bearing inner ring with a molybdenum disulphide paste or a similar fric-

Fig. 21



tion reducing substance. Tighten the lock nut until the withdrawal sleeve comes free. Finally, with the shaft properly supported, remove the sleeve and bearing from the shaft.

NOTE: If the threaded section of the sleeve protrudes beyond the shaft end or shaft shoulder, a support ring with the greatest possible wall thickness should be inserted in the sleeve bore to prevent distortion and damage to the thread when the nut is tightened (→ fig. 24).

Fig. 22

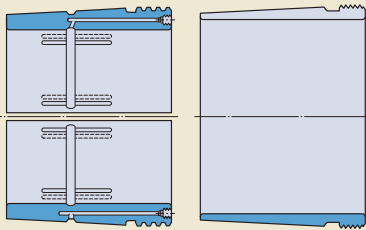


Fig. 24

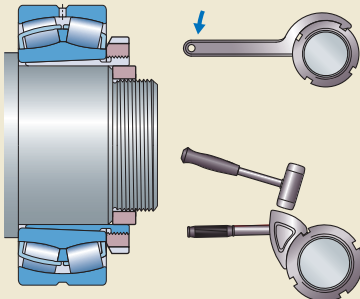
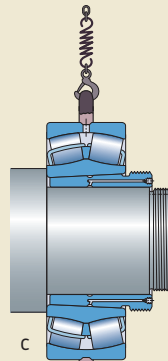
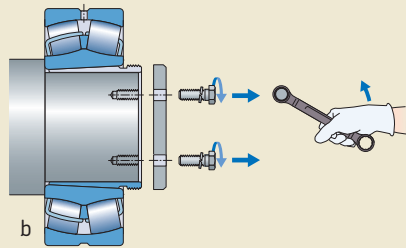
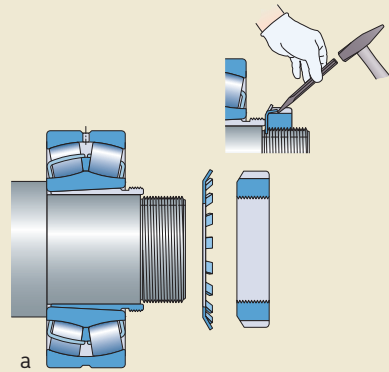


Fig. 23



Dismounting

Dismounting with a hydraulic nut

Medium-size and large bearings fitted on a withdrawal sleeve can be easily dismounted with a hydraulic nut.

WARNING

To avoid the risk of serious injury, attach a provision such as a lock nut for end plate to the shaft end (→ **fig. 25**) to limit the withdrawal sleeve travel when it suddenly comes loose.

Screw the hydraulic nut onto the thread of the withdrawal sleeve with the piston facing the bearing until the piston abuts the inner ring. Connect the hydraulic pump to the hydraulic nut and supply oil until the sleeve comes free. Once the sleeve is free, open the oil release valve of the hydraulic pump, so that the pressurized oil can leave the nut. Disconnect the hydraulic pump and remove the stop. Completely withdraw the sleeve from the shaft and remove the bearing.

NOTE: Detailed information about SKF hydraulic nuts is provided under *Hydraulic tools*, on **page 73**. Useful instructions for use can be found under *Oil injection method*, starting on **page 62**.

Dismounting using the oil injection method

Withdrawal sleeves with a bore diameter ≥ 200 mm are provided as standard with two oil supply ducts and an oil distribution groove in both the bore and outside surface. When using the oil injection method, two hydraulic pumps and appropriate extension pipes are needed (→ **fig. 26**).

First, clean the external thread as well as the threaded connection holes in the side face of the withdrawal sleeve. Screw the lock nut into position and tighten it. Connect both hydraulic pumps via the appropriate extension pipes to the sleeve. Inject oil with a viscosity of about $900 \text{ mm}^2/\text{s}$ at 20°C (70°F) under high pressure between the sleeve and the shaft through one duct and between the sleeve and bearing bore through the other one. The oil pressure between

Fig. 25

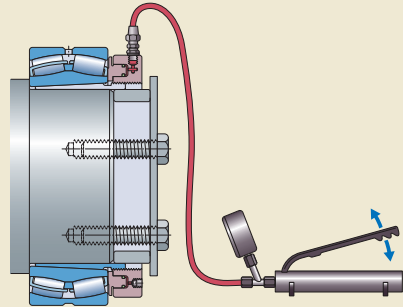
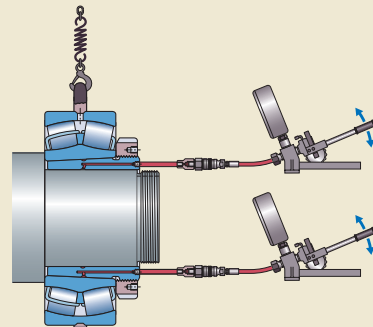


Fig. 26



the mating surfaces will increase until it drops suddenly, which indicates that the mating surfaces have separated. While tightening the lock nut, using an impact spanner for example, the sleeve will come free. Disconnect the hydraulic pumps and completely withdraw the sleeve from the shaft by means of the lock nut. Finally, remove the bearing.

NOTE: Detailed information about the oil injection method and appropriate equipment is provided under *Oil injection method*, starting on page 62.

Dismounting a bearing from a solid housing

Most bearings have a loose fit in the housing and should be easy to remove. However, if the application requires a tight housing fit or if bearing damage such as fretting corrosion has occurred, the bearing may need to be removed by force.

Manual dismounting

Bearings with an outside diameter up to 120 mm that are mounted in a housing bore without shoulders can be removed with a mounting dolly placed against the outer ring of the bearing, and a hammer. To do this, use the SKF Bearing fitting tool kit (→ page 72). Larger bearings require greater force to dismount and should be removed with a press.

If an integral shoulder behind the bearing in the housing bore does not allow the use of a mounting dolly or press, use a hammer and a soft metal drift punch to drive the bearing out of the housing. Light hammer taps should be applied evenly around the whole side face of the outer ring (→ fig. 27). Be careful when applying this method because it is very easy to damage the bearing and the housing bore.

Housing shoulders that have threaded holes (→ fig. 28) or slots (→ fig. 29) enable the use of screws, a bearing puller or a hammer and a drift punch to drive the bearing from the housing.

Fig. 27

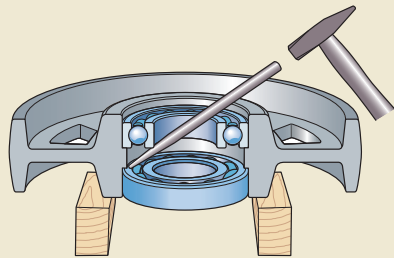


Fig. 28

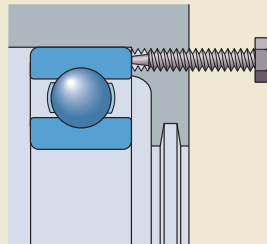
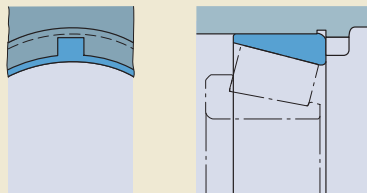


Fig. 29



Dismounting

Small bearings with a bore diameter ranging from 7 to 60 mm that are mounted in a housing can be removed from a housing bore using an internal puller with a slide hammer, such as the SKF Internal bearing puller kit (→ fig. 30).

To do this, place the jaws of the appropriate extractor through the bearing bore by squeezing the spring mechanism to close the puller arms (a). By releasing the spring mechanism, the extractor firmly grips the inner ring shoulder (b). The bearing can be extracted from the housing bore by repeatedly striking the stop ring with the slide hammer (c).

Dismounting using the oil injection method

If the necessary oil duct and distribution groove is designed into the housing and the bearing does not have a relubrication feature in the outer ring, the oil injection method can still be used. This method substantially reduces the amount of force required to remove larger bearings (→ fig. 31).

NOTE: Detailed information about the oil injection method can be found under *Oil injection method*, starting on page 62.

Fig. 31

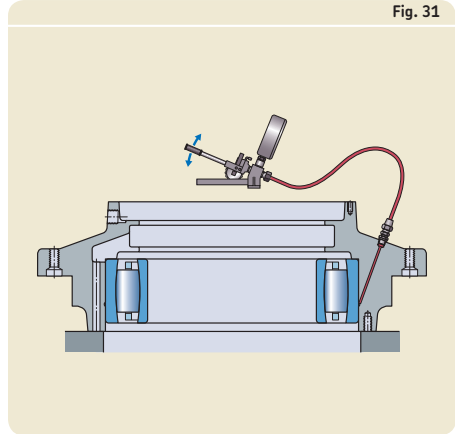
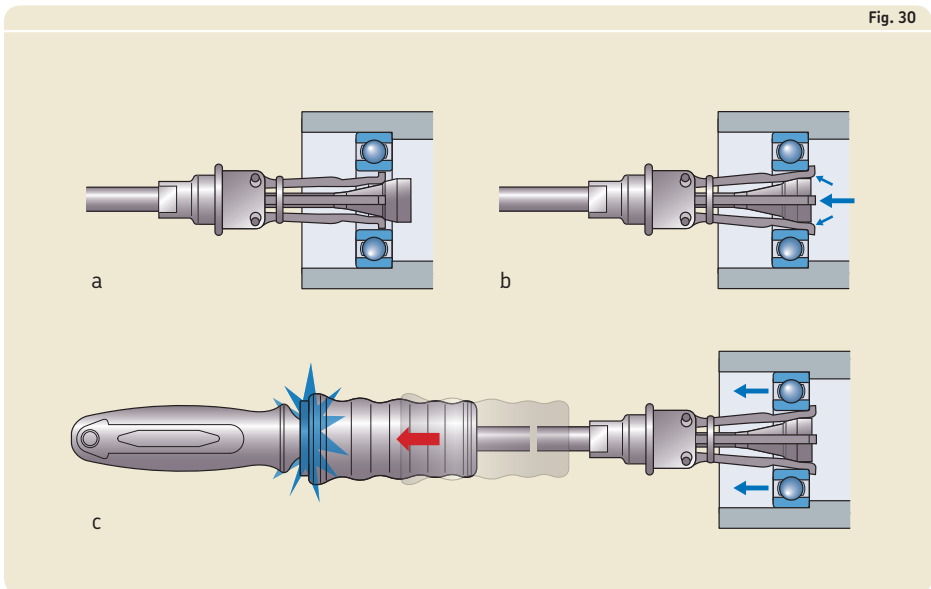


Fig. 30



Dismounting with heat

Heating a housing to remove the bearing using, for example, a heater mat (→ **fig. 32**), is not very common and should only be done as a last resort.

CAUTION: Never use a torch or other flame to heat the housing.

Dismounting a bearing from a shaft and a solid housing simultaneously

To dismount small deep groove ball bearings from a shaft and a solid housing simultaneously, special pullers (extractors) have been designed.

Fig. 33 shows a puller designed for bearings with a bore diameter ranging from 10 to 100 mm. The puller arms are placed between the balls and grip the inner ring raceway, while being supported by the outer ring.

Fig. 34 shows a puller designed for bearings with a bore diameter ranging from 30 to 160 mm. To apply the puller, the bearing cage needs to be removed first. The puller arms at the end are ball shaped with two flats. They are placed between the balls and grip both the inner and outer ring raceways.

For additional information about internal bearing puller kits, visit www.mapro.skf.com.

Fig. 32

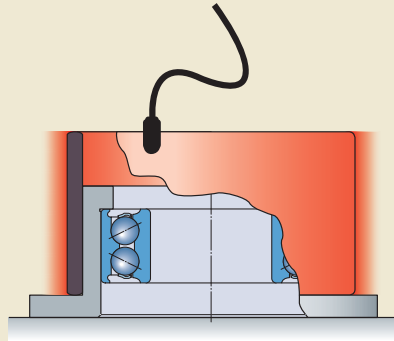


Fig. 33

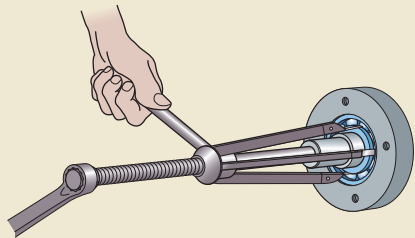
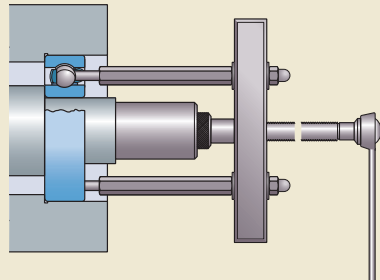


Fig. 34



Dismounting bearing units

What to remember

SKF bearing units (→ **fig. 35**) are available as plummer (pillow) block units, flanged units and take-up units. Depending on the size and type of bearing, they can be located on the shaft using any one of the following methods (→ **fig. 36**):

- grub (set) screw locking (**a**)
- single grub (set) screw eccentric locking collar (**b**)
- adapter sleeve locking (**c**)
- SKF ConCentra locking mechanism (**d, e**)
- double grub (set) screw cylindrical collar locking (**f**)

Therefore, the dismounting procedure and the tools appropriate for the job may differ. Appropriate tools include:

- a wrench or hexagonal key to loosen the attachment screws, bolts or nuts
- a hexagonal key to loosen the grub (set) screws in the inner ring or in the locking collar as specified in **table 3, page 102** in the chapter *Mounting bearing units*
- a hook spanner to loosen the adapter sleeve lock nut as specified in **table 4, page 103** in the chapter *Mounting bearing units*

In some cases, a dead-blow hammer may be necessary.

Hook spanners as well as dead blow hammers are part of the comprehensive range of SKF maintenance products. Detailed information can be found online at www.mapro.skf.com.

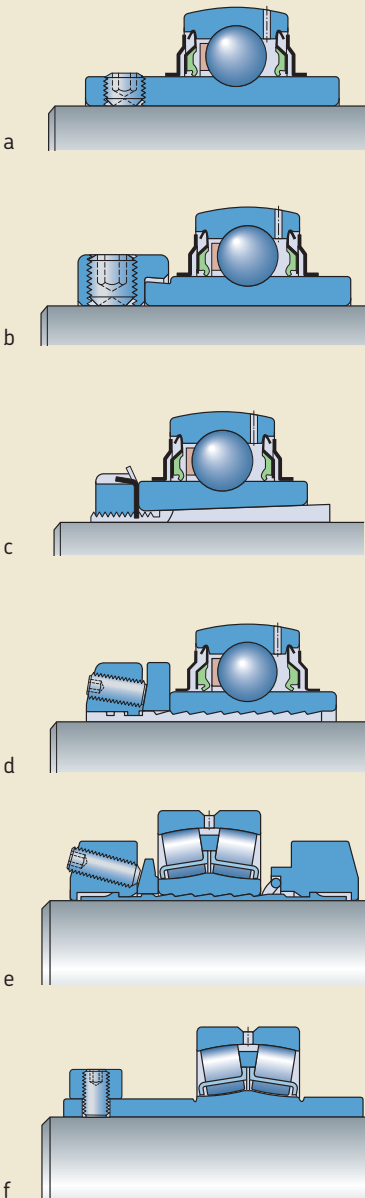
Once the bearing unit has been dismounted, check whether it can be reused. To do this, clean the outside surface of the unit, being careful not to damage the seals or get cleaning solvent into the bearing cavity. Turn the bearing slowly to feel for any damage. If applicable, relubricate the unit slowly via the grease fitting while rotating the inner ring. If it is determined that the unit is reusable, coat any untreated surfaces with grease, oil or anti-corrosive fluid to prevent corrosion.

NOTE: Small bearing units, which are very dirty, are generally not worth cleaning. Normally it is more economical to scrap the bearing and replace it with a new one.

Fig. 35



Fig. 36

**WARNING**

To minimize the chance of serious injuries, prior to starting any work, perform required lockout/tagout procedures.

Preparations prior to dismounting

Taking the time to prepare can make dismounting easier. If available, review the assembly drawing(s) and study the bearing unit arrangement. Then, before starting any work, do the following:

- Disconnect the power supply to the application.
- Clean the bearing unit and surrounding area thoroughly.
- Wipe the shaft clean.
- Check the locking method and choose appropriate tools for dismounting the bearing units.
- Check for and repair any damage that may prevent the unit from sliding off the shaft.
- Support the shaft to relieve any load on the bearing.

Dismounting

Dismounting ball bearing units with grub (set) screw locking

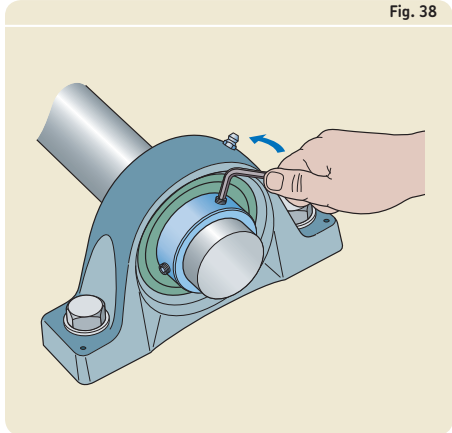
When dismantling ball bearing units with grub (set) screw locking (→ **fig. 37**), carefully read the guidelines provided under *What to remember*, starting on **page 270**, and do the following:

- 1 Loosen the grub (set) screws in the inner ring of both units, at least a full turn (→ **fig. 38**)
- 2 Unscrew and remove the attachment bolts.
 - For take-up units, disconnect the adjustment screw in the cast hole of both units.
- 3 Remove the units from the shaft.
 - For take-up units, pull the complete shaft/units assembly out of the take-up frames and remove the units from the shaft.
 - For pressed steel plummer (pillow) block units, remove the housing caps, lift out the shaft and remove the bearings from the shaft.
 - For pressed steel flanged units, remove the first housing cap and slide the bearing off the shaft. Then repeat on the other side.

Fig. 37



Fig. 38



Dismounting ball bearing units with an eccentric locking collar

When dismounting ball bearing units with an eccentric locking collar (→ **fig. 39**), carefully read the guidelines provided under *What to remember*, starting on **page 270**, and do the following (→ **fig. 40**):

- 1 Loosen the grub (set) screw in the eccentric locking collar of both units, at least a full turn (**a**).
- 2 Loosen the locking collar in the opposite direction of rotation. To do this:
 - Place a drift punch in the blind hole in the circumference of the collar and hit it with a hammer.
 - Or use a hook spanner with a stud engaging the blind hole in the circumference of the collar (**b**).
- 3 Remove the eccentric locking collar of both units from the shaft.
- 4 Unscrew and remove the attachment bolts.
 - For take-up units, disconnect the adjustment screw in the cast hole of both units.
- 5 Remove the units from the shaft.
 - For take-up units, pull the complete shaft/units assembly out of the take-up frames and remove the units from the shaft.
 - For pressed steel plummer (pillow) block units, remove the housing caps, lift out the shaft and remove the bearings from the shaft.
 - For pressed steel flanged units, remove the first housing cap and slide the bearing off the shaft. Then repeat on the other side.



Fig. 39

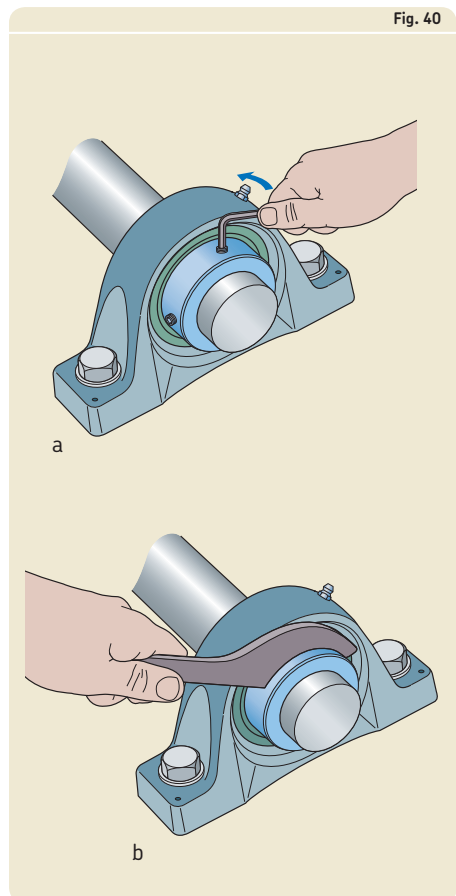


Fig. 40

Dismounting

Dismounting ball bearing units fitted on an adapter sleeve

When dismounting a ball bearing unit with an adapter sleeve (→ **fig. 41**), carefully read the guidelines provided under *What to remember*, starting on **page 270**, and do the following (→ **fig. 42**):

- 1 Disengage the bent tab of the lock washer from the lock nut slot (**a**) and unscrew the lock nut a few turns.
- 2 Loosen the attachment bolts or nuts a few turns.
- 3 Units with access to the opposite side of the locking device can be separated from the adapter sleeve with a steel block or drift punch and a hammer (**b**). Units without access to the opposite side of the locking device can be separated from the adapter sleeve by a couple of sharp hammer blows applied to a mounting dolly abutting the lock nut of the adapter sleeve (**c**).

NOTE: Use the SKF Bearing fitting tool kit for shaft diameters ≤ 55 mm (→ **page 72**).

- 4 Unscrew the lock nut and remove the lock washer on both units.
- 5 Remove the attachment bolts or nuts and slide the units off the sleeve along the shaft.
- 6 Remove the adapter sleeve from the shaft. To facilitate removal, expand the sleeve slightly by inserting a plastic wedge or a screwdriver in the slot of the sleeve.



Fig. 41

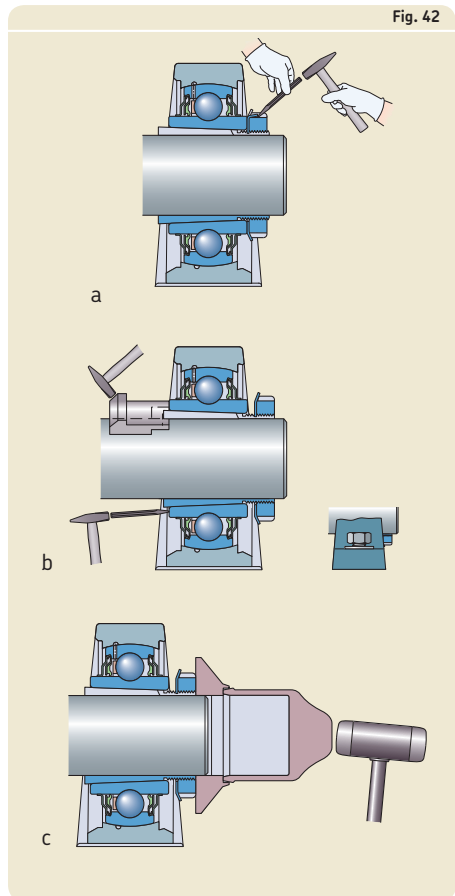


Fig. 42

Dismounting SKF ConCentra ball bearing units

Prior to dismounting an SKF ConCentra ball bearing unit (→ **fig. 43**), carefully read the guidelines provided under *What to remember*, starting on **page 270**, and do the following (→ **fig. 44**):

- 1 Loosen the grub (set) screws in the mounting ring of both units a few turns (**a**).
- 2 Loosen the attachment bolts or nuts of both units, but do not remove them.
- 3 Displace the mounting side ring until the SKF ConCentra stepped sleeve comes free:
 - by tapping the end of the shaft with a hammer (**b**)
 - by tapping a mounting dolly placed against the mounting ring (**c**)

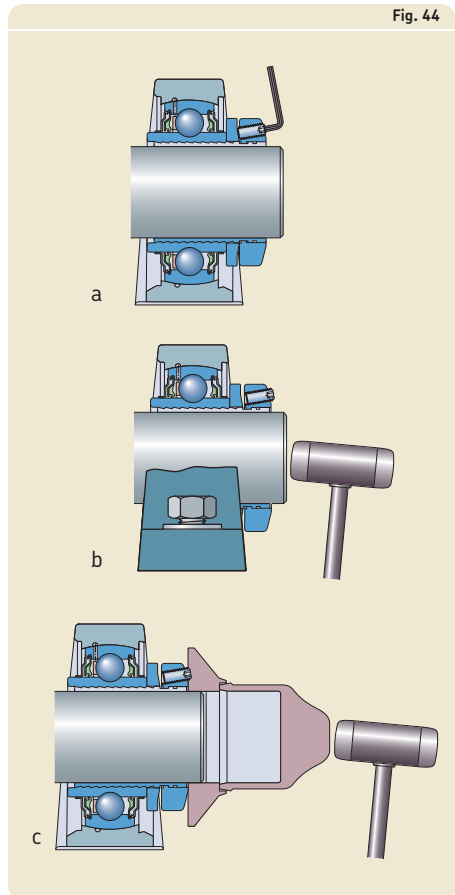
NOTE: Use the SKF Bearing fitting tool kit for shaft diameters ≤ 55 mm (→ **page 72**).

- 4 Remove the attachment bolts and remove the units from the shaft.

Fig. 43



Fig. 44



Dismounting

Dismounting SKF ConCentra roller bearing units

When dismounting roller bearing units with a plummer (pillow) block housing with SKF ConCentra locking (→ **fig. 45**), carefully read the guidelines provided under *What to remember*, starting on **page 270**, and do the following (→ **fig. 46**):

- 1 Loosen the attachment bolts and remove them. If possible, lift the complete bearing arrangement, i.e. shaft, both bearing units and associated components, out first, before dismounting the bearing units (**a**).
- 2 Place a support under the shaft.
- 3 Start with the locating bearing unit.
- 4 Loosen the grub (set) screws in the mounting collar by a few turns (**b**).
- 5 Face the mounting collar and while holding the base, pull the bearing unit until it releases from the shaft (**c**). The energy from the preloaded wave spring facilitates the release from the shaft. But, if necessary, use a rubber hammer to tap the collar on the opposite side of the unit (**d**).
- 6 Withdraw the bearing unit from the shaft.
- 7 To dismount the non-locating bearing unit, repeat **steps 4 to 6**.

Dismounting roller bearing units with a cylindrical locking collar

When dismounting a roller bearing unit with a cylindrical locking collar (→ **fig. 47**), carefully read the guidelines provided under *What to remember*, starting on **page 270**, and do the following:

- 1 Loosen the two grub (set) screws in the cylindrical locking collar of both units a few turns.
- 2 Unscrew and remove the attachment bolts.
 - For take-up units, disconnect the adjustment screw in the cast hole of both units.
- 3 Remove the units from the shaft. If needed, use a rubber hammer and lightly tap the unit until it releases from the shaft.
 - For take-up units, pull the complete shaft/unit assembly out of the take-up frame and remove the unit from the shaft.

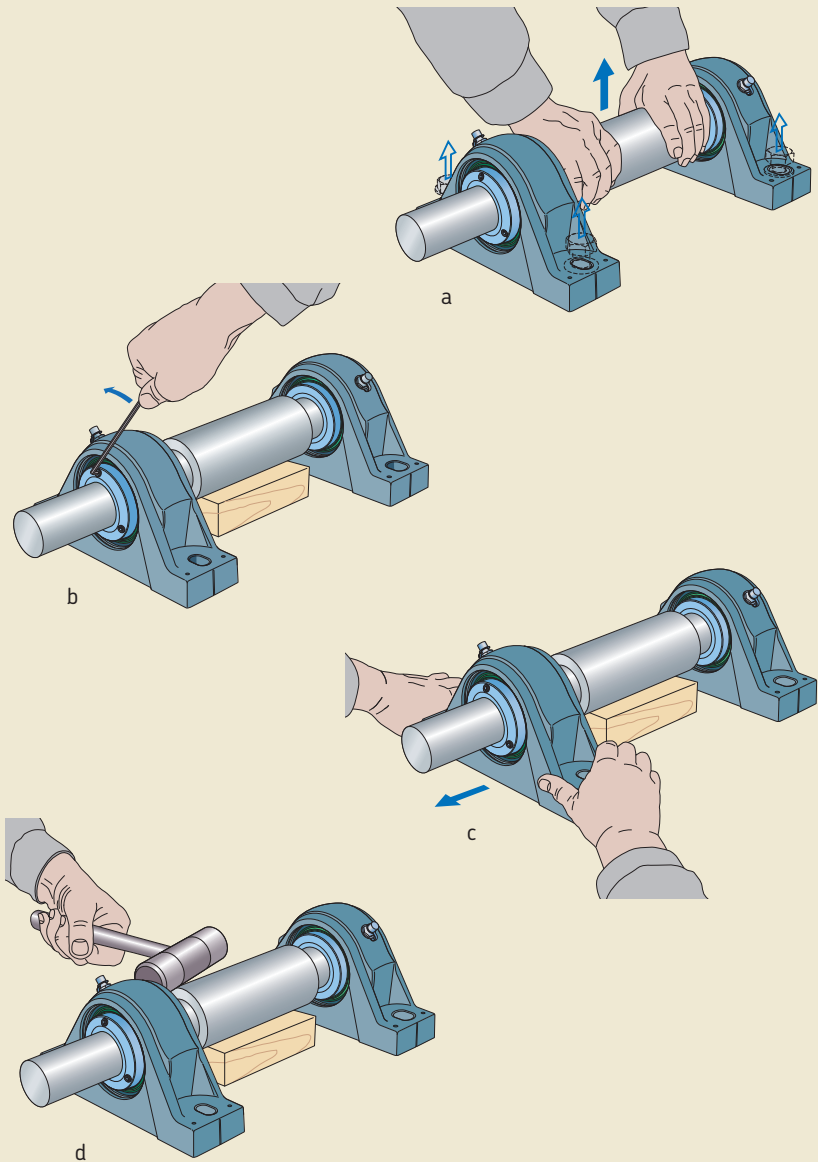
Fig. 45



Fig. 47



Fig. 46



Dismounting bearing housings

Bearing housings, which are used in a variety of industrial applications, are available in a wide range of designs and sizes. Information about how to dismount and disassemble the most popular plummer (pillow) block housings and flanged housings (→ **fig. 48**) can be found in this section. To obtain dismounting instructions for housings not included here, contact the SKF application engineering service.

What to remember

If a housing is to be used again, always dismount it carefully, taking the following into consideration:

- Keep the components of each housing together. The base and cap of individual housings are not interchangeable. The base and cap of SKF SNL, SONL and SAF housings are marked with a serial number.
- Handle all metal parts of solid seals carefully.
- Do not hit the housing directly with a hammer.

WARNING

To minimize the chance of serious injuries, prior to starting any work, perform required lockout/tagout procedures.

Preparations prior to dismounting

Taking the time to prepare can make dismounting easier. If available, review the assembly drawing(s) and study the bearing arrangement. Then, before starting any work, do the following:

- Disconnect the power supply to the application.
- Clean the housings and surrounding area thoroughly.
- Support the shaft with something such as lifting tackle.
- For split plummer (pillow) block housings, be sure that the proper tools are available to lift the shaft out of the housing base(s) (→ **fig. 49**).
- Have suitable containers on hand to retrieve lubricant samples and collect the used lubricant.

Check the housings for cracks prior to reuse. If a housing is deemed reusable, apply a coating of grease or oil to any unpainted surfaces to protect against corrosion.

Fig. 48

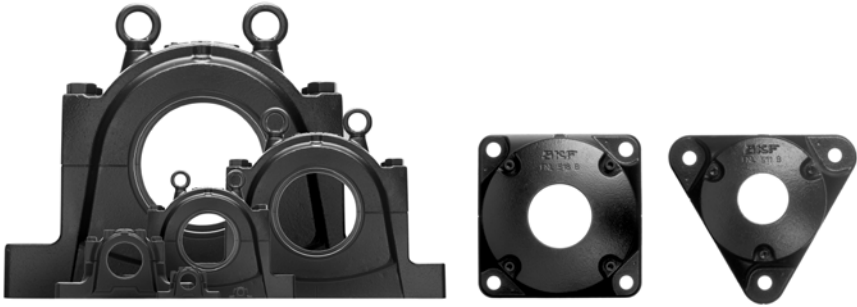
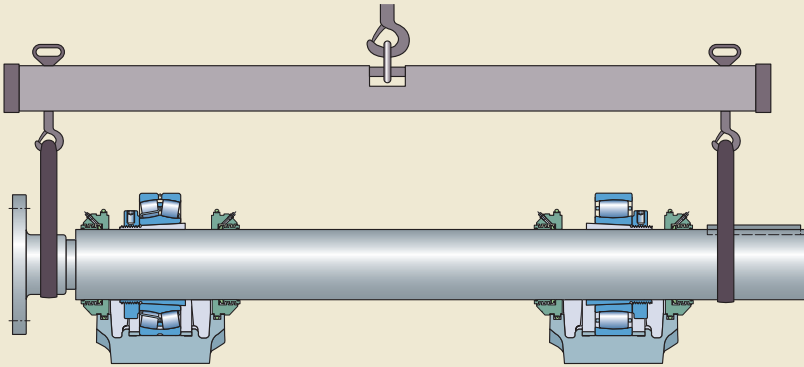


Fig. 49



Dismounting

Dismounting split plummer (pillow) block housings

When dismounting a standard plummer (pillow) block housing (→ **fig. 50**), carefully read the guidelines provided under *What to remember* on **page 278**, and do the following (→ **fig. 51**):

- 1 Remove any auxiliary connections to the housing, e.g. lubricant feed lines or other devices.
- 2 Loosen and remove the attachment bolts or nuts on both housings.

NOTE: If possible, lift the complete assembly (shaft, housings and other components) to a clean, open area.

- 3 Loosen and remove the cap bolts on both housings.
- 4 Remove the housing caps (**a**).

NOTE: All current SKF housings are provided with notches in the base and cap to accommodate a screwdriver or a pry bar.

- 5 If applicable, remove any excess grease and split seals from the housing caps (**b**).
- 6 Lift the shaft assembly from the housing bases (**c**).
- 7 Remove the other seal halves or the end cover, and the locating (stabilizing) rings, if applicable (**d**).

CAUTION: Do not reuse any contact seals.

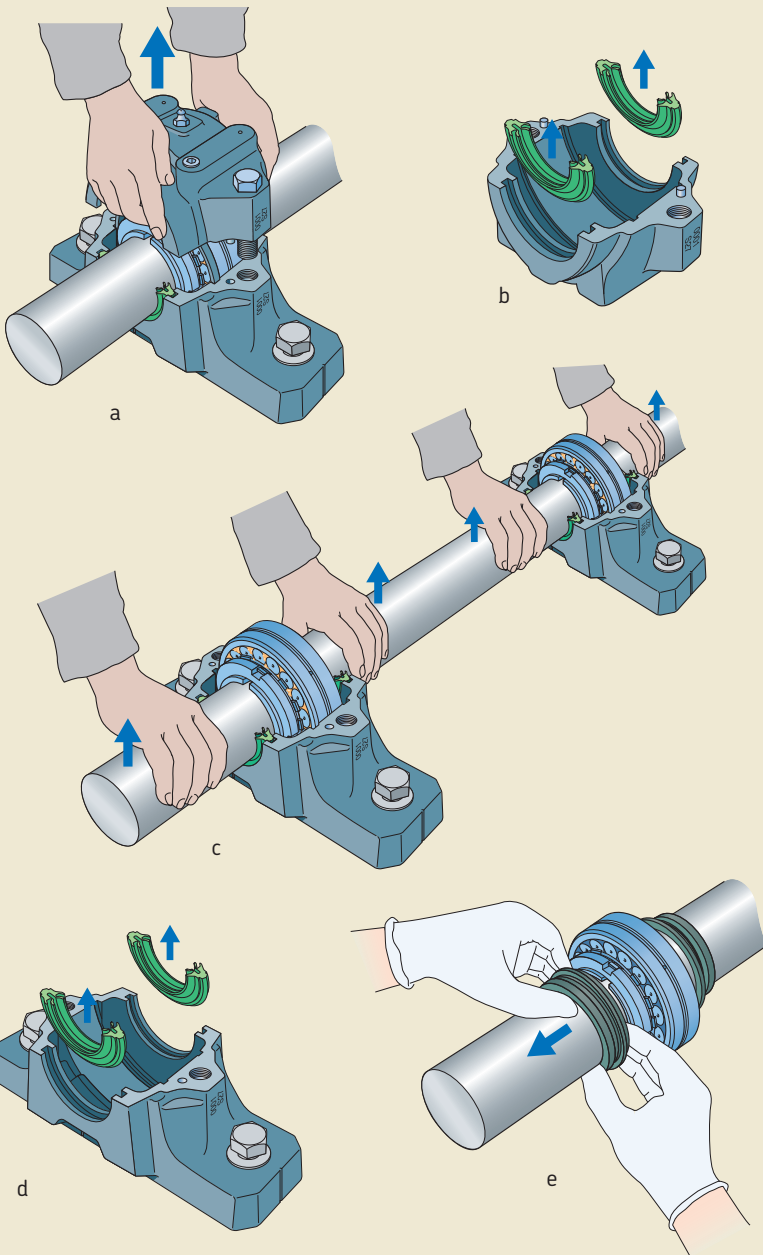
- 8 Remove any excess grease from the housing base.
- 9 Remove any solid seals from the shaft (**e**). V-rings can be cut.
- 10 Dismount the bearings from the shaft.
- 11 Remove the second sealing washer or ring from the shaft.

NOTE: Make sure all components for each housing are kept together.

Fig. 50



Fig. 51



Dismounting

Dismounting flanged housings

When dismantling a standard flanged housing (→ fig. 52), carefully read the guidelines provided under *What to remember* on **page 278** and do the following (→ fig. 53):

- 1 Loosen and remove the cover bolts on both housings.
- 2 Remove the cover and the locating (stabilizing) rings, if fitted.
- 3 Remove any excess grease from the cover and housing to expose the locking device on the adapter sleeve.
- 4 Disengage the bent tab of the lock washer from the lock nut slot and unscrew the lock nut a few turns (a).
- 5 Loosen the attachment bolts or nuts, but do not remove them.
- 6 Separate the bearing from the adapter sleeve
 - by hitting the shaft ends with a hammer (b)
 - by hitting a mounting dolly abutting the lock nut (c)

NOTE: Use the SKF Bearing fitting tool kit for shaft diameters ≤ 55 mm (→ **page 72**).

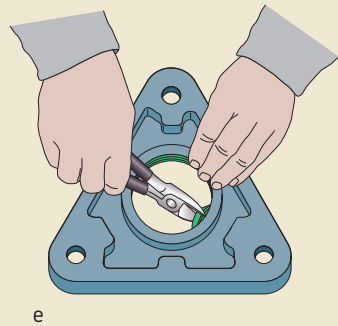
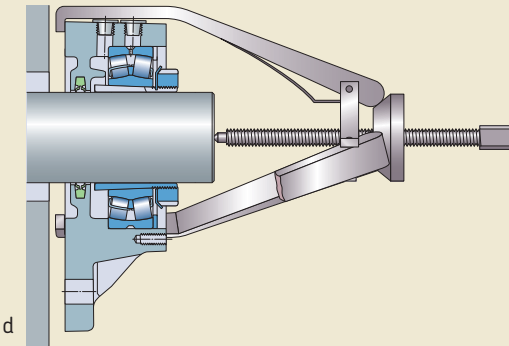
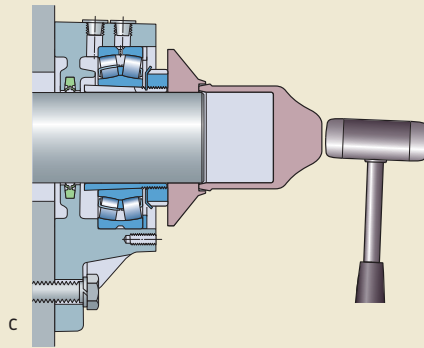
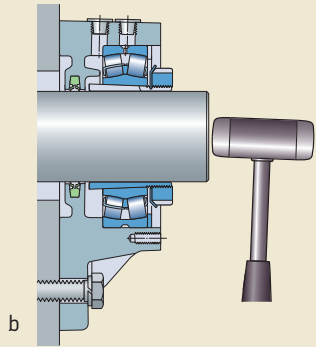
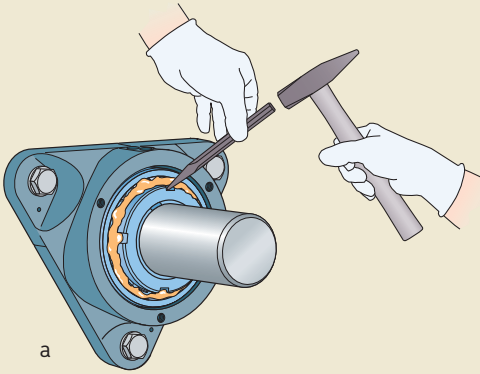
- 7 Unscrew the lock nut and remove the lock washer on both sides.
- 8 Remove the attachment bolts or nuts.
- 9 Separate the housing from its support surface and slide the housing, bearing and adapter sleeve off the shaft.
- 10 Use a puller if additional force is needed to free the bearing from the shaft (d).
- 11 Cut the seal from the seal groove (e).
- 12 Remove excess grease from the housing behind the bearing.
- 13 Dismount the bearing following the instructions listed under *Dismounting a bearing from a solid housing*, starting on **page 267**.

NOTE: Make sure all components for each housing are kept together.

Fig. 52



Fig. 53



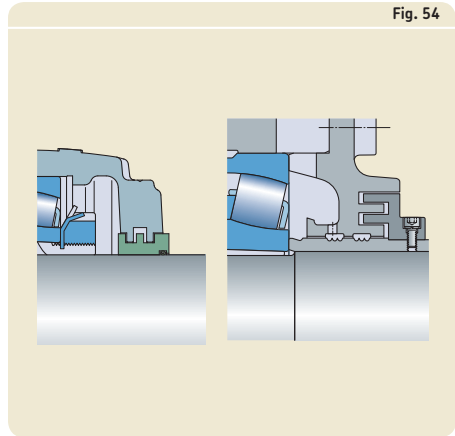
Removing seals

Generally, there are two different types of seals protecting rolling bearing arrangements: non-contact seals and contact seals.

Removing non-contact seals

Non-contact seals (→ **fig. 54**) generate almost no friction, enabling them to last a very long time. In most cases, these seals are reusable. Therefore, they should be removed very carefully, with the correct tools. Never hit a non-contact seal with a hammer or use a screwdriver or sharp drift punch during the removal process.

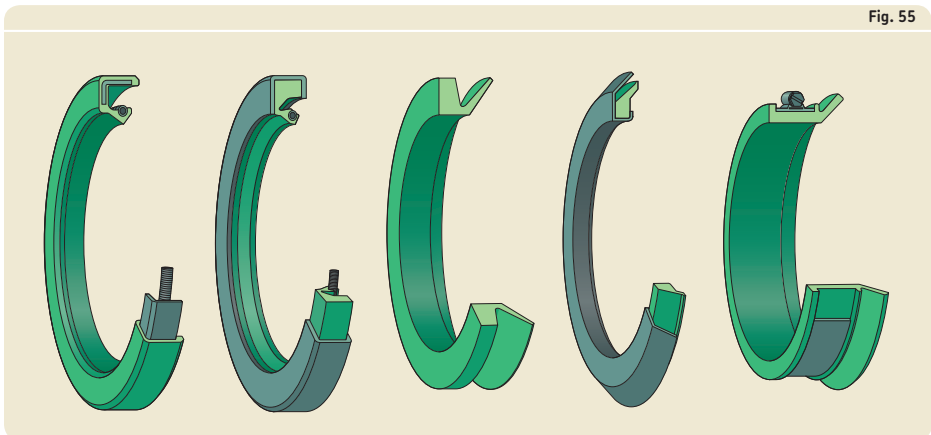
Prior to removing these seals, check for and repair any shaft damage that otherwise may damage the seal when sliding it off the shaft.



Removing contact seals

Contact seals (→ **fig. 55**), which are typically fixed in a housing and slide on a counterface, such as a shaft or distance ring, with a defined radial force, will wear over the time. Therefore, they should never be reused.

However if the cause of a seal failure is to be analyzed, they should be treated carefully during removal.



Radial shaft seals can be removed by:

- a hammer and a drift punch, if the housing shoulder has vent holes (→ **fig. 56**)
- a screwdriver, if the front or back face of the seal is accessible (→ **fig. 57**)
- tongs to grip the hinge or the shell of the seal (→ **fig. 58**)
- a mounting dolly, e.g. the SKF Bearing fitting tool kit (→ **fig. 59**)
- a hook to grip the shell from behind (→ **fig. 60**)

Fig. 58

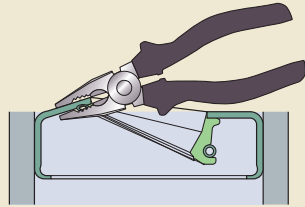


Fig. 56

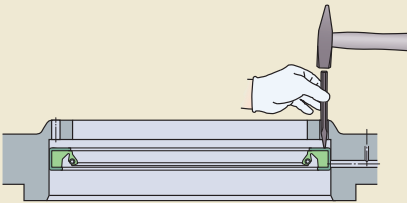


Fig. 59

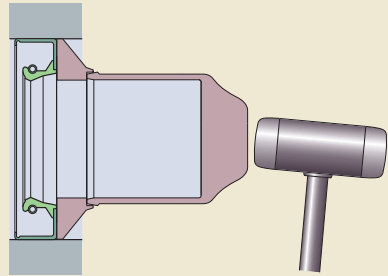


Fig. 57

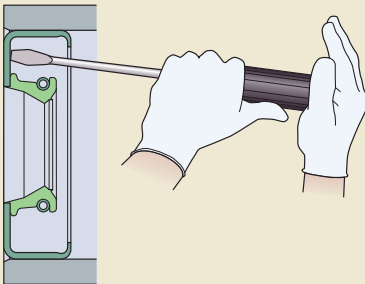
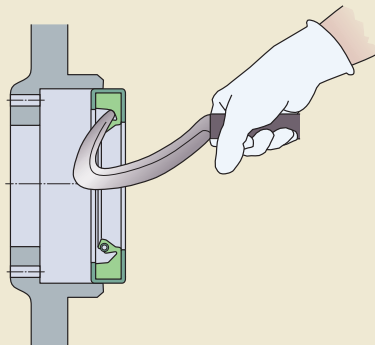


Fig. 60



Dismounting

V-ring seals can be removed by:

- stretching them over other components (→ **fig. 61**)
- cutting them with scissors (→ **fig. 62**)

Large all-elastomer radial shaft seals can be removed by:

- stretching or cutting them with scissors (→ **fig. 63**)
- disconnecting the spring connector on split seals (→ **fig. 64**)

Fig. 62

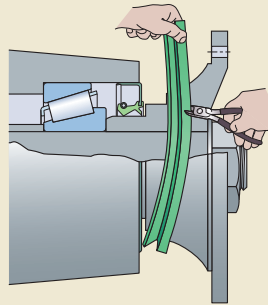


Fig. 63

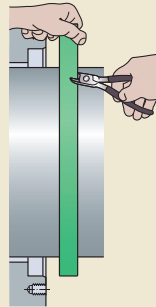


Fig. 61

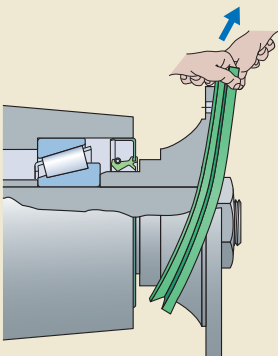
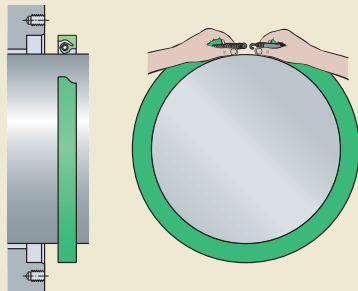


Fig. 64





Bearing damage and their causes

Introduction	290
Dismounting	291
Path patterns	291
Patterns resulting from normal operating conditions.	292
Patterns resulting from abnormal operating conditions.	296
Bearing damage	298
Pre-operational causes of damage	300
Incorrect shaft and housing fits.	300
Damage and failure due to defective shaft or housing seats	302
Static misalignment	304
Faulty mounting practices	305
Passage of excessive electric voltage through the bearing	307
Transportation and storage damage	308
Operational causes of damage.	309
Material fatigue (subsurface initiated)	309
Ineffective lubrication	310
Ineffective sealing	314
Vibration (false brinelling)	319
Operational misalignment	320
Passage of electric current through the bearing	321

Introduction

Rolling bearings are one of the most important components in today's high-tech machinery. When bearings fail, machine downtime occurs that can be costly. Selecting the appropriate bearing for the application is only the first step toward reliable equipment performance. The machine operating parameters, such as loads, speeds, temperature, running accuracy, and operating requirements, are needed to select the most appropriate bearing type and size from a range of available products.

The calculated life expectancy of any bearing is based on eight assumptions:

- 1 The bearing is of high quality and has no inherent defects.
- 2 The bearing is the right one for the application.
- 3 Dimensions of parts related to the bearing, such as shaft and housing seats, are appropriate.
- 4 The bearing is mounted correctly.
- 5 The correct lubricant, in the proper quantity, is always available to the bearing.
- 6 The bearing arrangement is properly protected (sealed).
- 7 The operating conditions are matched to the bearing arrangement.
- 8 Recommended maintenance is performed.

If all these conditions are met, the bearing should reach its calculated life. Unfortunately, this is quite hypothetical. There is often something that occurs, which prevents "ideal" operating conditions.

A common mistake in the field is to assume that if a bearing failed, it was because it did not have enough load carrying capacity. Using this rationale, many people go through expensive retrofits to increase bearing load carrying capacity, and end up with additional bearing failures.

Identifying the root cause of the bearing failure is the first step in obtaining reliable equipment performance. One of the most difficult tasks is identifying the primary failure mode (root cause) and filtering out any secondary conditions that resulted from the primary mode of failure.

Bearing damage analysis provides insight into equipment operation and bearing damage. Evidence needs to be collected and interpreted correctly to establish the root cause of the problem. Knowledge, skills and experience are required to separate useful information from false or misleading clues. This is why SKF offers professional damage analysis support.

For additional information about the SKF damage analysis service, contact your local SKF representative or SKF Authorized Distributor.

This chapter of the handbook provides you with the tools to make an initial evaluation of the cause of bearing damage or failure.

Dismounting

During dismounting, SKF recommends the following:

- Take pictures.
This might help in your investigation later. For example, be sure to photograph the position, quantity and condition of the grease in and around the bearing.
- Take lubricant samples for analysis.
For grease lubricated applications, take samples from different locations.

NOTE: Refer to *Dismounting*, starting on page 252.

Path patterns

A new bearing looks beautiful (→ **fig. 1**). Its components have been made to exacting dimensions, often to fractions of microns. The dimensions have been checked many times during the manufacturing process. The areas that have been ground, such as the surfaces of the inner and outer rings and rolling elements, look very shiny.

When examining a bearing that has run for some time, a number of changes can be observed, such as:

- dull areas on the raceways and rolling elements, sometimes also very shiny (→ **fig. 2**)
- discoloured inner ring bore and outer ring outside diameter
- cage wear
- fretting corrosion on the inner ring bore or outer ring outside diameter

Whether a bearing shows minor wear or damage, or has failed, a thorough inspection can provide information about what happened to the bearing during operation.

During the inspection, the key is to look for “patterns”. A pattern can be “normal” or it can indicate a problem. The pattern you find can quite frequently identify the root cause of a problem.

A number of common and typical patterns are shown in this chapter.



Fig. 1



Fig. 2

Bearing damage and their causes

Patterns resulting from normal operating conditions

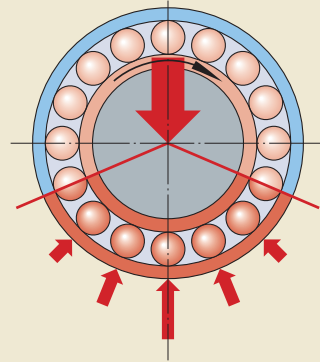
Figs. 3 and 4 illustrate how an applied uni-directional and constant radial load on the rotating inner ring of a bearing is distributed to the stationary outer ring, through the rolling elements.

The large arrow in the 12 o'clock position represents the applied load and the series of small arrows from 4 o'clock to 8 o'clock represent how the load is shared or supported through the rolling elements in the bearing.

As the inner ring is rotating, every point on the ring comes into the load zone. As a result, the entire circumference of the inner ring raceway will have a band in the centre that is uniform in width. This is referred to as a rotating inner ring load zone.

The outer ring is stationary; therefore the load zone is limited to where the rolling elements transmit the load. This is referred to as a stationary outer ring load zone. The load distribution in the outer ring load zone varies. It is heaviest in the direction of the load and decreases in either direction from that point. For most applications, the load zone is approximately 150°.

Fig. 3



- Load zone ($\approx 150^\circ$)
- Will enter the load zone during rotation
- Clearance in the bearing, unload zone
- Load (shaft) and load distribution (housing)

Fig. 4

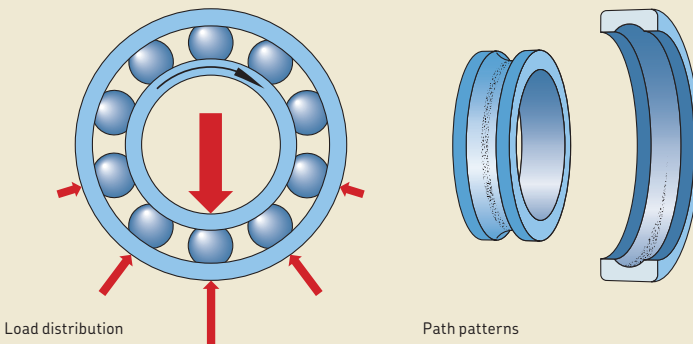
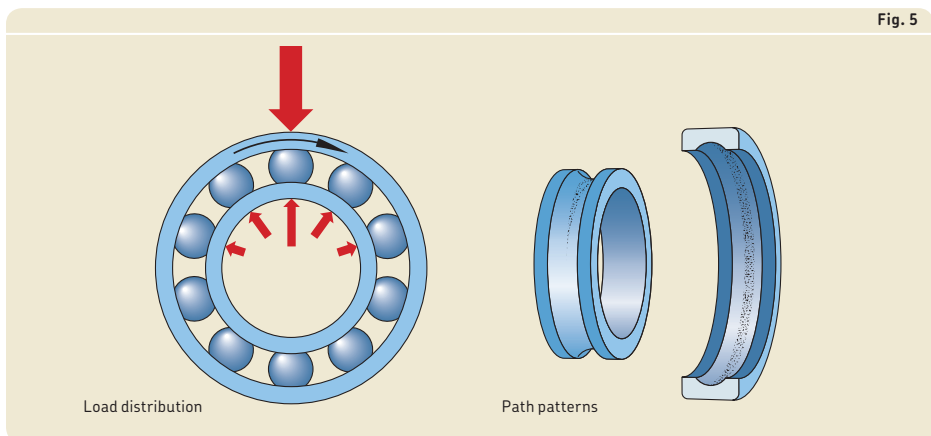


Fig. 5 illustrates how an applied unidirectional and constant radial load on the rotating outer ring of a bearing is distributed to the stationary inner ring through the rolling elements.

As the outer ring rotates, every point on that ring comes into the load zone. As a result, the entire circumference of the outer ring raceway will have a band in the centre that is uniform in width.

The load distribution on the inner ring varies. It is heaviest in the direction of the load and decreases in either direction from that point. For most applications, the load zone is approximately 150° .

Fig. 5



Bearing damage and their causes

These load patterns will also appear when the inner ring rotates in phase with the load (i.e. imbalanced or eccentric loads) and the outer ring is stationary. Even if the inner ring is rotating, the load on the inner ring is stationary, while the load on the stationary outer ring is rotating (→ **fig. 6**).

Fig. 7 illustrates the effect of a unidirectional and constant axial load on a deep groove ball bearing.

The rotating ring will show a laterally displaced band around its entire circumference.

The stationary ring will show a laterally displaced band on the opposite side. If the magnitude of the axial load is sufficient, the band on the stationary ring will be around its entire circumference.

Fig. 8 illustrates a combination of unidirectional and constant radial and axial loads on a deep groove ball bearing, with a rotating inner ring and stationary outer ring.

The load zone around the entire circumference of the inner ring is displaced laterally.

The load zone of the outer ring is displaced laterally in the opposite direction. The length of the load zone is greater than one that would be produced by just a radial load, but not necessarily 360°.

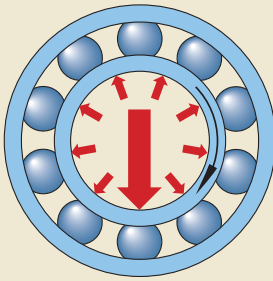
For double row bearings, combined loads will produce load zones of unequal length. The row that carries the axial load will have a longer stationary load zone. If the axial load is of sufficient magnitude, one row of rolling elements can become completely unloaded.

Under pure radial load, only a small section (approximately 150°) of the outer ring will have a path pattern (→ **figs. 3 and 4, page 292**).

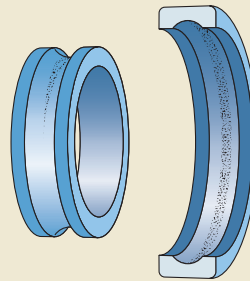
Under pure axial load, the whole outer ring will show a path pattern, which is laterally displaced (→ **fig. 7**).

Under a combined load, the path pattern will be somewhere in between, depending on the magnitude of the radial load relative to the axial load (→ **fig. 8**).

Fig. 6

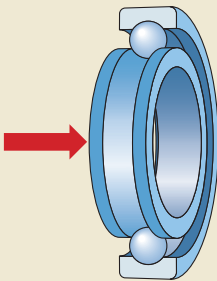


Load distribution

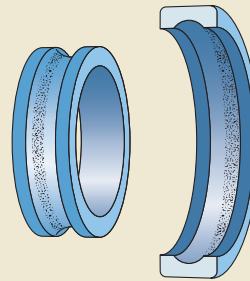


Path patterns

Fig. 7

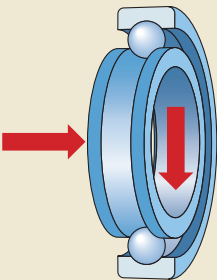


Load distribution

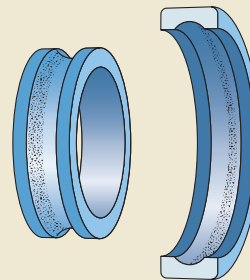


Path patterns

Fig. 8



Load distribution



Path patterns

Bearing damage and their causes

Patterns resulting from abnormal operating conditions

Fig. 9 illustrates the load zones produced by a unidirectional and constant radial load when a stationary outer ring is misaligned relative to the rotating inner ring.

The entire circumference of the inner ring raceway will have a band in its centre that is uniform in width.

The outer ring will have a band that goes from one side of the outer ring to the other. The path and length of the band depends on the magnitude of misalignment, the load and the clearance in the bearing. The band can be anywhere from 150° to 360°.

This condition can occur when the shaft deflects or if the bearings are in separate housings that do not have concentric housing bores.

Fig. 10 illustrates the load zones produced by a unidirectional and constant radial load when the stationary outer ring is radially pinched (oval clamped).

Under these conditions, the entire circumference of the inner ring raceway will have a band in its centre that is uniform in width.

The outer ring will show two diametrically opposed load zones. A radially pinched outer ring occurs for any one of the following reasons:

- The housing is mounted on a non-flat surface.
- The two halves of a split housing or a piece of equipment do not fit concentrically.
- The housing seat is out-of-round due to manufacturing errors, in which case two or more load zones are possible.

Multiple load zones dramatically increase the internal loads and increase the bearing operating temperature, leading to premature bearing damage or failure.

Fig. 11 illustrates the load zones produced by an internally preloaded bearing that is supporting a unidirectional and constant radial load, while the inner ring is rotating and the outer ring is stationary.

Under these conditions, the entire circumference of the inner ring raceway will have a band in its centre that is uniform in width.

The outer ring will also show a 360° load zone, but the pattern will usually be wider where the applied load is combined with the internal preload.

This condition can be the result of excessive interference fits on the shaft and/or in the housing. If the fits are too tight, the bearing can become internally preloaded by compressing the rolling elements between the two rings. Too little initial internal clearance can lead to the same problem.

Another possible cause for this condition is an excessive temperature difference between the shaft and housing. This too can significantly reduce the bearing internal clearance. Shaft and housing materials with a different coefficient of thermal expansion can also contribute to clearance reduction.

NOTE: Refer to *Recommended fits and tolerances*, on **page 35**.

Fig. 9

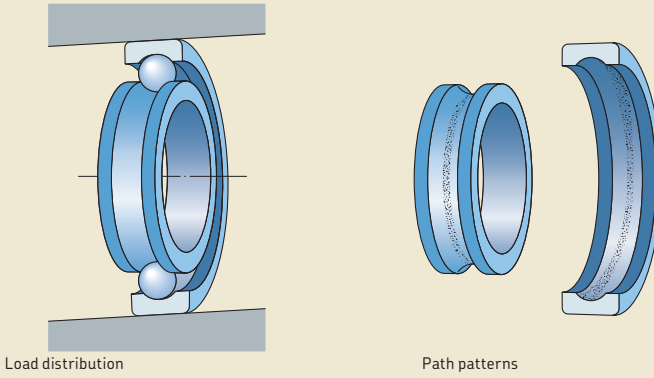


Fig. 10

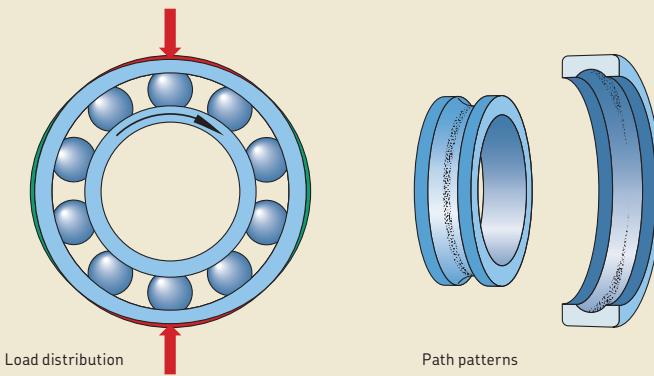
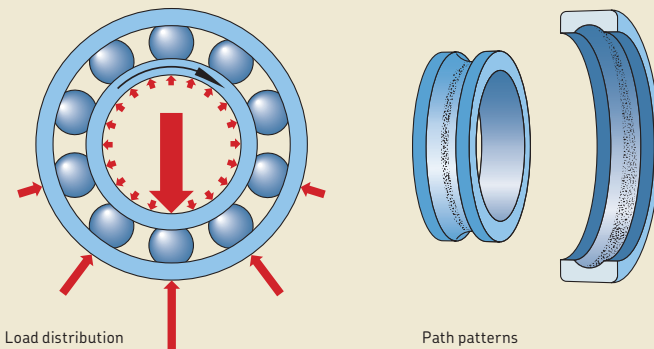


Fig. 11



Bearing damage

Because of the increasing attention given to prevent bearing damage and failures from recurring, the International Organization for Standardization (ISO) has developed a methodology for classifying bearing damage and failures (ISO 15243:2004). This standard recognizes six main groups of failure modes and sixteen subgroups, all related to post-manufacturing sustained damage. The standard is based primarily on features that are visible on the rolling elements, raceways and other functional surfaces. It also identifies the mechanisms involved for each type of failure.

Most bearing damage can be linked back to the six main groups as well as the various subgroups shown in **table 1**. Definitions of the failure modes are provided in **table 2**.

Most damage resulting from these mechanisms can be detected and monitored easily when condition monitoring is part of a comprehensive maintenance programme. Using vibration analysis, the first signs of bearing damage can be detected, enabling maintenance personnel to take corrective actions in a timely manner. This can significantly reduce costly, unexpected downtime and can avoid catastrophic failures that damage adjacent components. It also enables maintenance staff to examine the damaged bearing at an early stage to determine the root cause, and take the necessary steps to prevent the problem from recurring.

NOTE: Refer to *Inspection*, starting on **page 216**.

Most bearing damage can be classified into two damage categories: pre-operational and operational. Pre-operational damage occurs prior to or during bearing installation, while operational damage occurs while the bearing is in operation.

Causes of pre-operational damage:

- incorrect shaft and housing fits
- defective bearing seats on shafts and in housings
- static misalignment
- faulty mounting practices
- passage of electric current through the bearing (excessive voltage)
- transportation, handling and storage

Causes of operational damage:

- material fatigue
- ineffective lubrication
- ineffective sealing
- vibration (false brinelling)
- operational misalignment
- passage of electric current through the bearing (current leakage)

Table 1

ISO classification of bearing damage and failure modes

Main group	Subgroup
Fatigue	Subsurface initiated fatigue Surface initiated fatigue
Wear	Abrasive wear Adhesive wear
Corrosion	Moisture corrosion Frictional corrosion Fretting corrosion False brinelling
Electrical erosion	Excessive voltage Current leakage
Plastic deformation	Overload Indentation from debris Indentation from handling
Fracture and cracking	Forced fracture Fatigue fracture Thermal cracking

Table 2

Failure mode definitions and explanations

Failure mode	Definition and/or explanation
Fatigue	A change in the material structure that is caused by the repeated stresses developed in the contact areas between the rolling elements and the raceways. Fatigue is manifested visibly as spalling of particles from the surface. The time between beginning and advanced spalling varies with speed and load.
Subsurface initiated fatigue	The initiation of microcracks below the raceway surface. When these microcracks propagate to the surface, they produce spalls (flaking).
Surface initiated fatigue	Distress of the surface. Failure of the rolling contact metal surface asperities (roughness) due to inadequate lubrication.
Wear	The progressive removal of material resulting from the interaction of two sliding or rolling/sliding contacting surfaces during operation.
Abrasive wear	The result of inadequate lubrication or the ingress of contaminants.
Adhesive wear	The material transfer from one surface to another with friction heat, sometimes with tempering or rehardening of the surface.
Corrosion	The deterioration of a metal surface as a result of oxidation or a chemical reaction on metal surfaces.
Moisture corrosion	Oxidation of the surfaces in the presence of moisture.
Frictional corrosion	The chemical reaction activated by relative micromovement between mating surfaces under certain friction conditions.
Fretting corrosion	The oxidation and wear of surface asperities under oscillating micromovement.
False brinelling	The formation of shallow depressions resulting from micromovement caused by cyclic vibrations when a machine is at a standstill. Equally spaced depressions matching the rolling element pitch appear in the raceways.
Electrical erosion	The damage to contact surfaces (removal of material) caused by the passage of electric currents.
Excessive voltage	Sparking and localized heating from current passage in the contact area because of ineffective insulation.
Current leakage	The generation of shallow craters from (low) current passage. The craters are closely positioned to one another. They develop over time into flutes parallel to the rolling axis and are equally spaced.
Plastic deformation	Permanent deformation that occurs whenever the yield strength of the material is exceeded.
Overload	Overloading by static or shock loads, leading to plastic deformation (true brinelling).
Indentation from debris	Particles that are over-rolled in the contact areas form dents in the raceways and rolling elements. The size and shape of the dents depend on the nature of the particles.
Indentation from handling	Bearing surfaces that are dented or gouged by hard, sharp objects.
Fracture	The ultimate tensile strength of the material is exceeded and complete separation of a part of the component occurs.
Forced fracture	A fracture resulting from a stress concentration in excess of the material's tensile strength.
Fatigue fracture	A fracture resulting from frequently exceeding the fatigue strength limit of the material.
Thermal cracking	Cracks that are generated by high frictional heating. They usually occur perpendicular to the direction of the sliding motion.

Bearing damage and their causes

Pre-operational causes of damage

Incorrect shaft and housing fits

An incorrect shaft or housing fit can result in either excessive clearance or excessive pre-load, which can produce any of the following conditions:

- ring creep (ring turns on its seat)
- fretting corrosion
- cracked rings
- reduced load carrying capacity
- induced loads
- excessive operating temperatures

Therefore, the proper fit is critical to the service life of the bearing and the performance of the application.

If a bearing ring rotates and the load is unidirectional and constant, an interference fit is required. The degree of interference or tightness is governed by the magnitude of the load and the bearing type and size. Typically, the heavier the applied load, the tighter the required fit.

If a bearing ring is stationary and the load unidirectional and constant, it is typically fitted with a loose fit. Recommended fits can be found in **Appendix A**, starting on **page 334**. Values for deviations and resultant fits are listed in **Appendix B**, starting on **page 338**.

The presence of shock loads or continuous vibration requires a heavier interference fit on the ring that rotates relative to the load.

In the case of a bearing ring with a rotating load zone, lightly loaded bearings, or bearings that operate at very low speeds, a lighter fit or, in some cases a loose fit, can be applied.

Sometimes, it is not possible to assemble a piece of equipment if the recommended fits are applied. In these cases, contact the SKF application engineering service.

Consider two examples: In the front wheel of a car, the direction of the load is constant, i.e. the road surface is always exerting an upward force on the wheel. Thus, the rotating outer ring has an interference fit in the wheel hub, while the stationary inner ring has a loose fit on the axle spindle.

Bearings in a conventional electric motor have stationary outer rings relative to the load and have a loose housing fit, but the inner rings rotate relative to the load and are mounted with an interference fit.

There are some cases where it is necessary to mount both the inner and outer rings of a bearing with an interference fit. This is the case, for example, with cylindrical roller and CARB toroidal roller bearings, which can accommodate axial expansion of the shaft within the bearing, rather than through sliding of one of the bearing rings on its seat. This can also be the case for applications where heavy shock loads occur.

Improper shaft or housing fits, or fits that are unnecessarily loose, can enable the inner or outer ring to rotate on its seat. This relative movement is called ring creep. The relative movement generates friction and can result

Fig. 12

Abrasive wear due to outer ring creep
ISO classification: Abrasive wear

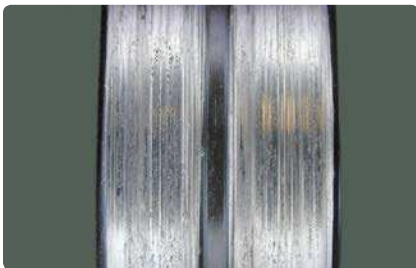


Fig. 13

Polishing wear due to outer ring creep
ISO classification: Abrasive wear



in wear or smearing. The damage is not always confined to the seat surface, but can also have its effect on the side faces of the ring(s).

Fig. 12 shows abrasive wear, while **fig. 13** shows polishing wear.

Fits that are too loose can result in a speed difference between contact surfaces. Sometimes a loose fit cannot be avoided, for example, for four row tapered roller bearings on the roll necks in rolling mills. Typically, the inner ring has a loose fit for mounting/dismounting reasons. Due to the loose fit, there is a speed difference between the inner ring and the shaft seat (creep), and between the inner ring side face and its abutment. These speed differences in the contact zone will generate heat. In some cases, the localized heat can be so intense that material is transferred from the bearing ring to its sliding surfaces or vice versa (smearing) (→ **fig. 14**). The heat can also produce heat cracks in the material (→ **fig. 14**), which will eventually cause the ring to crack (thermal cracking).

An interference fit between an inner ring and shaft will induce hoop (tensile) stresses in the ring. If the interference fit is excessive, the resultant hoop stresses can exceed the strength of the ring, causing it to fracture (→ **fig. 15**).

Bearing arrangements typically consist of a locating and a non-locating bearing. The non-locating bearing is designed to accommodate thermal expansion of the shaft, either within the bearing or by moving on its seat in the housing. To move on its seat, the outer ring requires a loose fit. If the fit is too tight or the outer ring is cocked in the housing, the ring will not move. This induces heavy axial loads in the bearing system. These heavy axial loads can produce any of the following conditions: premature material fatigue, excessive heat, inadequate lubrication, excessive wear or surface initiated spalling (→ **fig. 16**). The result is drastically reduced bearing service life.

Fig. 14

Different speeds in the contact area between the bearing and a distance ring caused smearing (circumferential marks). The resultant heat caused thermal cracks in the bearing ring (perpendicular to the smearing marks).
ISO classification: Adhesive wear and thermal cracking

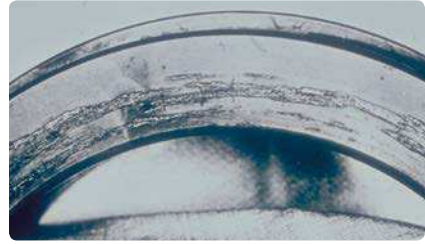


Fig. 15

Ring cracking due to an excessive interference fit
ISO classification: Forced fracture



Fig. 16

A housing fit that is too tight for a non-locating bearing will induce heavy axial loads, drastically reducing bearing service life.

ISO classification: Subsurface initiated fatigue (from too heavy loads) or surface initiated fatigue (from lubrication problems)



Bearing damage and their causes

Damage and failure due to defective shaft or housing seats

The formulas used to calculate bearing life make basic assumptions. One of those assumptions is that shaft and housing seats meet geometrical specifications. Unfortunately, there are other factors that can negatively affect components that were manufactured to the most exacting specifications. For example, shaft and housing seats can be deformed, i.e. tapered, out-of-round, out-of-square, or thermally distorted. The same condition can be produced by a bearing seat in a housing that was correctly manufactured, but became distorted when it was secured to the machine frame or support surface.

While the section *Incorrect shaft and housing fits*, starting on **page 300**, dealt with poorly selected fits, this section focuses on distorted bearing seats and the damage they can cause.

Fretting corrosion occurs when the fit is too loose and there is relative movement between a bearing ring and the shaft or housing. The relative movement, which is typically caused by form inaccuracies or shaft bending (deflection), causes small particles of material to become detached from the surface of the shaft or housing seat. These particles oxidize quickly when exposed to air.

As a result of fretting corrosion, the bearing rings may not be evenly supported, which will have a detrimental effect on the load distribution in the bearing. Fretting corrosion appears as rust on the outside surface of the outer ring (→ **fig. 17**) or in the bore of the inner ring (→ **figs. 18 and 19**). Iron oxide has a larger volume than pure iron. Therefore, the bearing geometry might change; the raceway path pattern could be heavily marked at corresponding positions.

Fretting corrosion is common in applications where operating conditions cause the seats to deform under load. This is very often the case in heavily loaded applications.

NOTE: Fretting corrosion Fe_3O_4 , also called magnetite (→ **fig. 17**), can be black – or Fe_2O_3 , also called hematite, is red or reddish brown (→ **figs. 18 and 19**).

Fig. 17

“Heavy” fretting corrosion occurs often in heavily loaded applications. The fretting corrosion is in the load zone of the outer ring seat.
ISO classification: Fretting corrosion



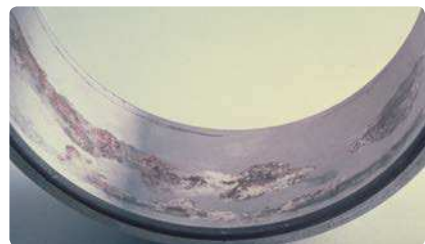
Fig. 18

Fretting corrosion from an incorrect shaft fit
ISO classification: Fretting corrosion



Fig. 19

Fretting corrosion from either an imperfect shaft seat (machining) or shaft deflection
ISO classification: Fretting corrosion



Over time, incorrect contact will result in advanced fretting corrosion. The corroded areas also act as fracture notches (→ **figs. 20 and 21**).

Bearing seats that are concave, convex, or tapered, cause a bearing ring to make poor contact across its width. The ring, therefore, deflects under load and fatigue fractures commonly appear circumferentially along the raceway.

Fig. 22 is a mirror picture of a self-aligning ball bearing outer ring that was mounted in an out-of-round (oval) housing bore. The stationary outer ring was pinched in two places – 180° apart – resulting in preload at these two locations. The preload generated excessive forces, which resulted in premature material fatigue and subsurface initiated spalling.

The preload also generated heat and led to a poor lubrication condition. Notice the heavy fretting corrosion (180° apart) on the outer ring outside diameter corresponding to the two load zones.

Fig. 20

Fretting corrosion can lead to ring fracture. The ring cracks at its weakest point – the lubrication groove. ISO classification: Fretting corrosion and forced fracture



Fig. 21

The outer ring of this bearing was not well supported in the housing seat. Fretting corrosion led to high stresses in the outer ring and ultimately resulted in a forced fracture.

ISO classification: Fretting corrosion and forced fracture



Fig. 22

The outer ring of this self-aligning ball bearing is placed against a mirror. Two load zones and spalling can be seen 180° apart. The damage resulted from an out-of-round housing seat.

ISO classification: Subsurface initiated fatigue



Bearing damage and their causes

Static misalignment

Static misalignment, a common cause of overheating and/or premature spalling is present when any of the following conditions exist:

- The inner ring is seated against a shaft shoulder that is not square with the bearing seat.
- The outer ring is seated against a housing shoulder that is not square with the housing bore.
- The two housing bores are not concentric or coaxial.
- A bearing ring is fitted improperly against its shoulder and left cocked on its seat.
- The outer ring of a non-locating bearing is cocked on its seat.

Self-aligning bearings cannot cure all misalignment faults. For example, when the rotating inner ring of a self-aligning bearing is not square with its shaft seat, it will wobble as it rotates. This can cause lubrication problems, and either premature wear and/or early surface initiated fatigue.

Thrust ball bearings can show signs of early fatigue when mounted on supports that are not perpendicular to the shaft. In these cases only one short section (arc) of the stationary ring carries the entire load. When the rotating ring of a thrust ball bearing is mounted on an out-of-square shaft shoulder, the ring wobbles as it rotates. The wobbling rotating ring loads only a small portion of the stationary ring and causes early fatigue.

Where two housings supporting the same shaft do not have a common centre line, only self-aligning ball or roller bearings will be able to function without inducing bending moments that otherwise result in shaft deflections and misalignment. Deep groove and angular contact ball bearings as well as cylindrical and tapered roller bearings can accommodate only very small misalignments. Misalignment in these bearings typically causes edge loading, which can result in premature fatigue.

The double row angular contact ball bearing as shown in **fig. 23** was misaligned. It resulted in two load zones 180° apart. The heavy induced loads led to an ineffective lubrication condition. Both the heavy loads and lubrication problem led to premature bearing damage, which started as surface spalling.

The tapered roller bearing shown in **fig. 24** was installed in a misaligned housing. The load was carried only over a small area at the edge. The resulting very high stresses in this area led to material fatigue and premature subsurface initiated spalling.

Fig. 23

Misaligned double row angular contact ball bearing: The misalignment resulted in two load zones 180° apart. Heavy loads, resulting stresses and lubrication problems led to premature bearing failure.
ISO classification: Surface initiated fatigue



Fig. 24

Misalignment of the housing caused edge loading in this tapered roller bearing. The result: premature bearing failure.
ISO classification: Subsurface initiated fatigue



Faulty mounting practices

Abuse and neglect before and during mounting often lead to damage and premature fatigue or failure.

One of the primary causes of early fatigue failures is impact damage during handling, mounting, storage, and/or operation.

In these cases, the impact is higher than the strength of the material (overload), which plastically deforms. Damage starts at the point of deformation and ultimately results in premature bearing failure.

Fig. 25 shows that the mounting force, applied to the wrong ring, passed through the rolling elements. This can also occur if the bearing is subjected to abnormal loading while not running. As the impact load is an axial load, dents can be found in the rings that are axially displaced from the centre. The distance between the dents is the same as the rolling element spacing.

Fig. 26 shows damage to the inner ring of a double row angular contact ball bearing. In this case the mounting force was applied via the outer ring. The resulting plastic deformation is equally spaced indentations that correspond to the distance between the balls.

Fig. 27 shows the resulting damage to a deep groove ball bearing after it has been in operation for some time.

Another cause of early fatigue failures is the presence of contaminants trapped in the bearing or housing. The contaminants can be introduced during mounting or could be the result of residual contaminants from a

Fig. 25

Mounting force applied to the wrong ring
ISO classification: Overload

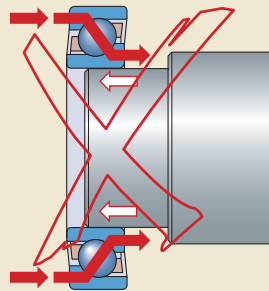


Fig. 26

Damage caused by impact during mounting
ISO classification: Overload



Fig. 27

Fatigue caused by impact damage during mounting
ISO classification: Overload



Bearing damage and their causes

previous bearing failure. Contaminants can also be introduced as a result of the housing manufacturing process.

The effect of trapping a chip between the outside diameter of the bearing and the bore of the housing will also lead to premature bearing failure.

Cylindrical roller bearings can be damaged easily during assembly. This can happen, for example, with NU design bearings after the inner ring is fitted to the shaft and the outer ring with the cage and roller assembly is in the housing. If the shaft is askew during assembly, and not rotated, the rollers can scratch (plough) the raceway of the inner ring (→ **fig. 28**), causing indentations in the form of long, transverse streaks. Notice that the spacing (→ **fig. 29**) of the damaged area matches the distance between the rollers.

NOTE: This can be avoided: Lubricate all components well and rotate the inner ring while mounting. For larger bearings, a mounting sleeve should be used (→ **fig. 30**).

Fig. 28

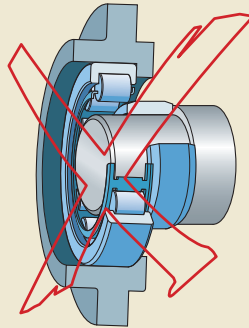
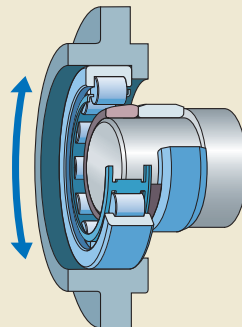


Fig. 29

Assembly damage on a cylindrical roller bearing
ISO classification: Indentation by handling



Fig. 30



Passage of excessive electric voltage through the bearing

Under certain conditions, electric current will pass through a bearing seeking ground. For example, when repairing a shaft, excessive voltage potentials can result from improperly grounding the welding equipment. As electricity arcs from one bearing ring to the rolling elements and from there to the other ring, severe damage occurs. **Fig. 31** shows excessive electric voltage damage on the outer ring raceway and roller surface of a large spherical roller bearing.

The damage can occur at standstill but usually occurs during operation. Nevertheless, this type of damage is classified as pre-operational.

Fig. 31

Damage to a large spherical roller bearing due to passage of excessive electric voltage. Left: damage to the outer ring raceway; right: corresponding damage to the roller.
ISO classification: Excessive voltage



Bearing damage and their causes

Transportation and storage damage

Damage typically associated with transportation includes true brinelling (overload) from shock loading or false brinelling from vibration.

True brinelling is the result of an impact. Impact can occur as a result of improper bearing handling or shock loads in an application. Depending on the severity of the damage, true brinelling will increase noise and vibration levels and reduce bearing service life. To identify true brinelling, check that the distance between the damaged areas matches the distance between the rolling elements. Since true brinelling is the result of an impact, the original grinding lines can be visible under magnification.

Fig. 32 shows a 100 × magnification of the damage due to an (overload) impact.

False brinelling damage also matches the distance between the rolling elements. However, since it is caused by vibration, the grinding marks have disappeared, as shown in **fig. 33**. False brinelling will also lead to increased noise and vibration levels, depending upon the severity.

When in storage, the bearing packaging should remain in good condition, otherwise the bearing condition might deteriorate. This is also valid for bearings already mounted in subassemblies (→ **fig. 34**). The bearings should be adequately protected.

Fig. 32

Impact mark from an overload (true brinelling) –
100 × magnification
ISO classification: Overload



Fig. 33

Marks from false brinelling – 100 × magnification
ISO classification: False brinelling



Fig. 34

Damage from inappropriate stocking
ISO classification: Moisture corrosion



Operational causes of damage

Material fatigue (subsurface initiated)

In operation, load is transmitted from one ring to the other through the rolling elements. Every time a rolling element comes into the load zone, the load transmitted in the contact area goes from zero to a maximum and back to zero. This leads to a build-up of residual stresses in the material. Depending on the load, temperature and the number of stress cycles, these stresses will lead to structural changes in the material and result in the formation of cracks underneath the surface. These cracks will finally propagate to the surface and spalling will occur (→ fig. 35).

A bearing is damaged as soon as the first spall occurs. This does not mean that the bearing cannot continue to operate. Spalls will gradually increase in size (→ fig. 36) and number and give rise to increased noise and vibration levels in the machinery. The machine should be stopped and repaired before the bearing fails catastrophically.

To avoid premature subsurface initiated fatigue, three major conditions must exist:

- clean bearing steel – best quality bearing
- good lubrication conditions (no contamination)
- good load distribution over the rolling elements and along the rolling element contact line

Fig. 35

A spall in a bearing
ISO classification: Subsurface initiated fatigue



Fig. 36

Advanced spalling due to subsurface initiated fatigue of the material
ISO classification: Subsurface initiated fatigue



Ineffective lubrication

One of the primary assumptions made when calculating the life expectancy of a bearing, is that the bearing will be lubricated properly. This means that the correct lubricant in the right quantity will reach the bearing at the right time. All bearings require adequate lubrication for reliable operation. The lubricant separates the rolling elements, cage and raceways, in both the rolling and sliding regions of contact. Without effective lubrication, metal-to-metal contact occurs between the rolling elements and the raceways and other contact surfaces, causing damage to these surfaces.

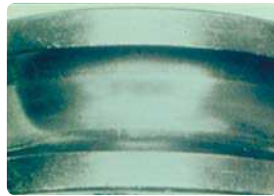
The term “lubricant failure” is too often taken to imply that there was no oil or grease in the bearing. While this might happen occasionally, a bearing damage analysis is normally not that simple. Many damage cases are the result of insufficient lubricant viscosity, excessive lubricant viscosity, over-lubrication, inadequate lubricant quantity, contaminated lubricant or the wrong lubricant being used in the application. Therefore, a thorough examination of the lubricant properties, the amount of lubricant applied to the bearing, and the operating conditions are pertinent to any lubrication damage analysis.

When lubrication is ineffective, damage in the form of surface fatigue will result. This damage might progress rapidly to failures that are often difficult to differentiate from failures due to material fatigue or spalling. Spalling will occur and often destroy the evidence of ineffective lubrication. However, if found early enough, indications that pinpoint the real cause of damage will be visible.

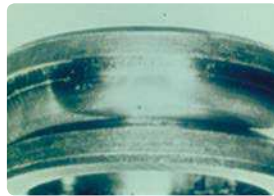
Stages of damage due to inadequate lubrication (surface distress) are shown in **fig. 37**. The first visible indication of trouble is usually a fine roughening or waviness on the surface. Later, fine cracks develop, followed by spalling.

Fig. 37

Progressive stages of spalling (surface distress) caused by ineffective lubrication
ISO classification: Surface initiated fatigue



Stage 1: Fine roughening or waviness develops on the surface.



Stage 2: Surface distress and small cracks develop. Then microspalling occurs.



Stage 3: The debris is over-rolled; real surface spalling develops.



Stage 4: If run too long, the whole raceway is spalled; initial damage can no longer be observed.

Fig. 38 shows an inner ring raceway of a large spherical roller bearing. Due to inadequate lubrication, fatigue of the surface has occurred. Spalling has already started on the outer sides of the raceway contact. **Fig. 39** shows an outer ring of a spherical roller bearing. Here, spalling is advanced.

Fig. 38

Surface distress on the outer sides of the inner ring raceway contact in a large spherical roller bearing
ISO classification: Surface initiated fatigue



Fig. 39

Advanced spalling resulting from surface distress in the outer ring of a spherical roller bearing
ISO classification: Surface initiated fatigue



Bearing damage and their causes

Another form of surface damage is called smearing (adhesive wear). Smearing (skidding) can occur under any of the following conditions:

- relatively high speeds
- insufficient load
- lubricant too stiff
- excessive clearance
- insufficient lubricant in the load zone

When the rolling elements are subjected to severe accelerations on their re-entry into the load zone, sliding can occur. The heat generated by these sliding contacts may be so high that the two surfaces melt together at the points of metal-to-metal contact. This welding process causes material to be transferred from one surface to the other, which also leads to higher friction, and local stress concentrations with a high risk that cracks will occur and the bearing will fail prematurely.

Fig. 40 shows the outer ring of a spherical roller bearing. Each row exhibits a patch of smearing. Notice the two wear patterns in the load zone. Another example of smearing is shown in **fig. 41**.

Smearing can also occur in applications where the load is too light relative to the speed of rotation. Sliding of the rolling elements leads to a rapid increase in temperature, which can cause local melting, and the transfer of material from one surface to the other (→ **fig. 42**).

Smearing can also occur in areas such as locating flanges and roller side faces in cylindrical and tapered roller bearings, guide ring and roller side faces in spherical roller bearings and the thrust side of rollers and raceways of spherical roller thrust bearings (→ **fig. 42**).

Fig. 40

Smearing in the re-entry side of the load zone in the outer ring of a spherical roller bearing
ISO classification: Adhesive wear

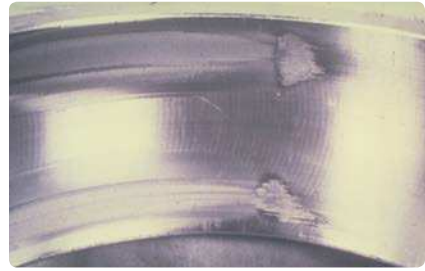


Fig. 41

Smearing on one raceway of the stationary inner ring of a spherical roller bearing
ISO classification: Adhesive wear



Fig. 42

Smearing on the thrust side of a roller of a spherical roller thrust bearing
ISO classification: Adhesive wear



Wear in a bearing as a whole also results from ineffective lubrication. **Fig. 43** illustrates this type of damage.

Most metallic cages are not hardened. With ineffective lubrication, wear often starts in the cage pockets (→ **figs. 44** and **45**).

Fig. 43

Wear due to ineffective lubrication in a spherical roller bearing
ISO classification: Abrasive wear



Fig. 44

Wear due to ineffective lubrication: solid brass cage of a cylindrical roller bearing
ISO classification: Abrasive wear



Fig. 45

Advanced wear due to ineffective lubrication: solid steel cage of a single row angular contact ball bearing
ISO classification: Abrasive wear



Bearing damage and their causes

Ineffective sealing

This section deals with damage to bearings due to ineffective sealing arrangements.

When contaminants enter the bearing cavity, bearing service life will be reduced. It is therefore extremely important to protect the bearings with either integral seals or shields or external seals. In severely contaminated environments, it can be advantageous to use both sealing solutions.

When solid contaminants enter a bearing, the lubricant can lose its effectiveness and wear can occur. This is an accelerating process, because the lubricant will continue to deteriorate and the wear will destroy the microgeometry of the bearing. The speed of this process depends largely on the type of contaminant and whether the wear particles remain in the bearing, or are removed (relubrication). Most of the time, wear results in dull surfaces (→ **figs. 46 to 48**).

Fig. 46 shows the outer ring of a spherical roller bearing with two wear bands in the load zone. Some waviness, due to vibration during operation, is also visible. **Fig. 47** shows the inner ring of a spherical roller bearing in an application with outer ring rotation. The wear is advanced in both raceways and spalling has started. **Fig. 48** shows the inner ring of a large spherical roller bearing in an application with outer ring rotation. The wear is very advanced and spalling has started. Each raceway has two wear zones. Wear occurred in one zone. Then, due to inner ring creep (turn), wear started in the second zone.

Fig. 46

Wear in a spherical roller bearing outer ring
ISO classification: Abrasive wear

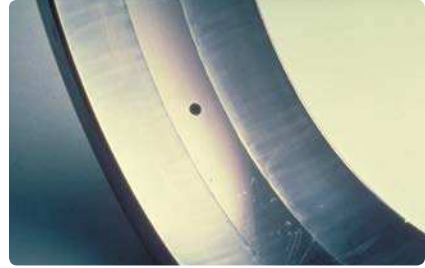


Fig. 47

Advanced wear on a stationary inner ring of a spherical roller bearing
ISO classification: Abrasive wear



Fig. 48

Very advanced wear on the stationary inner ring of a large spherical roller bearing
ISO classification: Abrasive wear



Sometimes, wear particles or other solid contaminants will act as a polishing agent and the contact surfaces become extremely shiny. The extent of this depends on the size of the particles, their hardness and time (→ **figs. 49** and **50**).

Fig. 49

Polishing wear in a spherical roller bearing
ISO classification: Abrasive wear



Fig. 50

Polishing wear on the inner ring of a large spherical roller bearing
ISO classification: Abrasive wear



Bearing damage and their causes

Solid contaminants that enter into the bearing cavity cause indentations when over-rolled in the raceways by the rolling elements. The damage done to the raceways depends on the type of contaminant. Very hard particles, such as Al_2O_3 (material from a grinding stone), produce indentations with sharp corners, which cause high stresses in the damaged area. Soft contaminants like a thin piece of paper or the thread from a cotton cloth can also cause harmful indentations.

Every indentation has the potential to initiate premature fatigue.

Fig. 51 shows an indentation from an over-rolled piece of metal wire in a very large spherical roller bearing.

Fig. 52 shows indentations in a very large spherical roller bearing. The large number of indentations would significantly reduce bearing service life.

Fig. 53 shows a deep groove ball bearing with indentations due to contaminants. Spalling started at the two points indicated by the circles and continued on from there.

Fig. 51

An indentation from a piece of metal wire in a very large spherical roller bearing
ISO classification: Indentation from debris



Fig. 52

Indentations from debris in a large spherical roller bearing
ISO classification: Indentation from debris



Fig. 53

Spalling in a deep groove ball bearing due to indentations
ISO classification: Indentation from debris



Corrosion is another problem that occurs as a result of an ineffective sealing arrangement, mostly at standstill.

Water, acid, and many cleaning agents deteriorate lubricants, resulting in corrosion.

When water, acid or cleaning agents enter an application, it negatively affects the ability of the lubricant to protect steel surfaces from oxidation. As a result, when a machine is at a standstill, deep-seated rust forms easily.

Over time, the excessive moisture will form an acid in the lubricant and etch the surface black, as shown in **fig. 54**.

In the presence of water and due to capillary action, the area next to the rolling element contact zone might become corroded (→ **fig. 55**). This corrosion appears as greyish black streaks across the raceways, which usually coincide with the distance between the rolling elements (→ **fig. 56**).

Fig. 54

Moisture acids in a spherical roller bearing
ISO classification: Moisture corrosion

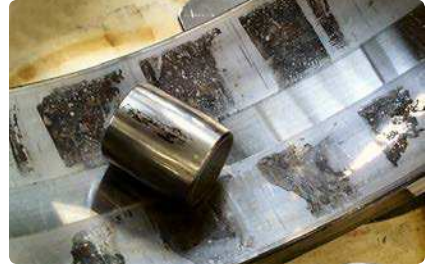


Fig. 55

Due to capillary action, the area next to the rolling element contact zone might become corroded.
ISO classification: Moisture corrosion

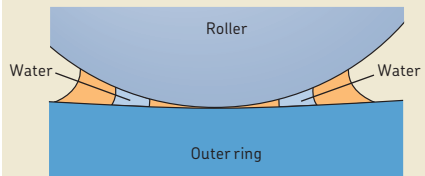


Fig. 56

Corrosion streaks caused by water in the lubricant
ISO classification: Moisture corrosion



Bearing damage and their causes

When water, acid, or cleaning agents have compromised the lubricant's ability to protect steel surfaces, and the standstill is prolonged, the entire surface of the rings and rolling elements can become corroded (→ **figs. 57** and **58**).

Fig. 57

Rust on an outer ring of a spherical roller bearing caused by moisture during prolonged standstill
ISO classification: Moisture corrosion



Fig. 58

Rust on a roller of a spherical roller bearing caused by moisture during prolonged standstill
ISO classification: Moisture corrosion



Vibration (false brinelling)

Vibration, mostly during standstill, is another cause of bearing damage. As in the case of auxiliary and standby equipment, vibration damage can be caused by nearby machinery that is in operation. Depending on the proximity of the idle unit to the operating one(s), vibration created from the running equipment causes the rolling elements in the bearing of the static machine to vibrate. Depending on the intensity and frequency of the vibration, the condition of the lubricant and the load, a combination of corrosion and wear occurs, forming shallow depressions in the raceway.

The depressions, which have the same spacing as the rolling elements, are often discoloured (reddish) or shiny (sphered depressions for ball bearings, lines for roller bearings).

The magnitude and duration of the vibration and the bearing internal clearance can influence the damage. Roller bearings seem more susceptible to this type of damage than ball bearings.

Fig. 59 shows the result of vibration damage in a self-aligning ball bearing in a standby unit.

Fig. 60 shows a similar result in a CARB toroidal roller bearing due to prolonged standstill.

Fig. 61 shows false brinelling in the outer ring of a cylindrical roller bearing. The bearing was fitted to the electric motor of an auxiliary piece of equipment. There were several stops and starts. At every standstill, vibration damage occurred. Several sets of “flutes” at roller spacing can be observed. The three arrows show the heaviest damage – at roller spacing – during a prolonged standstill.

Fig. 59

Vibration damage in a self-aligning ball bearing in a standby unit
ISO classification: False brinelling



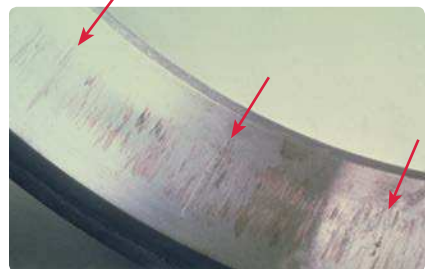
Fig. 60

Vibration damage in a CARB toroidal roller bearing due to prolonged standstill
ISO classification: False brinelling



Fig. 61

Vibration damage in a cylindrical roller bearing in an auxiliary piece of equipment
ISO classification: False brinelling



Bearing damage and their causes

Operational misalignment

Causes of operational misalignment include shaft deflections caused by heavy loads or load amplitude changes during operation (imbalanced load). When operational misalignment is present, load zones are not parallel to the raceway grooves (→ **fig. 9** on **page 297**). The result is induced axial loads, which can be dangerous, because they can lead to fatigue fracture. **Fig. 62** shows the outer ring of a NNCF double row full complement cylindrical roller bearing. The outer ring flange is almost completely broken off, due to fatigue from induced axial loads resulting from shaft deflection.

Fig. 62

Fatigue fracture of the outer ring flange in a double row full complement cylindrical roller bearing
ISO classification: Fatigue fracture



Passage of electric current through the bearing

For damage due to excessive voltage, refer to *Passage of excessive electric voltage through the bearing* on **page 307**.

However, current damage can occur even if the intensity of the current is relatively low. Stray electric currents can be caused by any one of the following: frequency inverters, flux asymmetries, motor design, unsymmetrical cabling, grounding and driven machinery. Initially, the surface is damaged by shallow craters, which are closely positioned to one another and so small that magnification is necessary (→ **figs. 63** and **64**).

Cutting through the material and enlarging to approximately 500 × magnification shows the material change (→ **fig. 65**). The white area shows that the metal has been rehardened, typically 66 to 68 HRC. This material is very hard and brittle. Below the hardened area is a black layer, annealed by the heat, which is softer than the surrounding bearing material (56 to 57 HRC).

Fig. 63

Current leakage: Small craters can be observed at 500 × magnification.
ISO classification: Current leakage

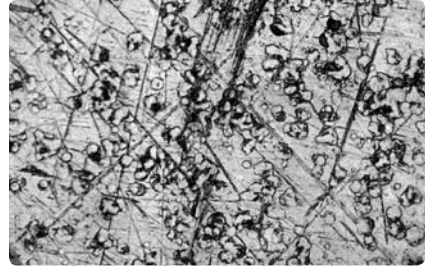


Fig. 64

Craters (1 000 × magnification)
ISO classification: Current leakage

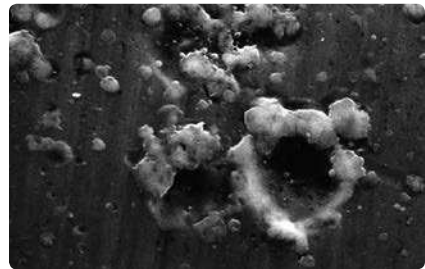
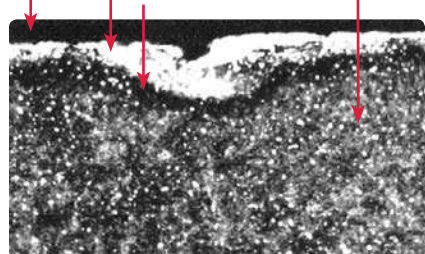


Fig. 65

Material change: Bearing ring cross section at 500 × magnification

ISO classification: Current leakage

Rehardened 66–68 HRC (white) Normal 58–62 HRC
Raceway Annealed 56–57 HRC (black)



Bearing damage and their causes

The extent of damage depends on a number of factors: bearing type, the intensity of the current (Amperes), duration, bearing load, bearing clearance, speed and lubricant. Over a period of time, flutes (also called washboarding effect) will develop from the craters (→ **figs. 66** and **67**), parallel to the rolling axis. They can be considerable in depth, producing noise and vibration during operation. Eventually, the bearing will fail due to metal fatigue. Apart from the fluting pattern on the rings and rollers of the bearings, there are two more signs that can indicate damage from stray electric currents: a darkened grey dull discoloration of the rolling elements (→ **fig. 68**), together with a very fine darkened grey matt discoloured load zone. The grease on or near the cage bars will be (carbonized) black (→ **fig. 69**).

Current damage can also happen from static electricity emanating from charged belts or from manufacturing processes involving leather, paper, cloth or rubber. These stray currents pass through the shaft and bearing to ground. When the current bridges the lubricant film between the rolling elements and raceways, microscopic arcing occurs.

NOTE: To avoid problems with damage from current leakage, SKF recommends using bearings that provide insulation: hybrid or INSOCOAT bearings. Electrical discharge detector pens from SKF can help detect the presence of electrical discharge currents in rolling bearings.

Fig. 66

Flutes (washboarding) in an early stage in a spherical roller bearing
ISO classification: Current leakage



Fig. 67

Flutes in an advanced stage in a deep groove ball bearing
ISO classification: Current leakage

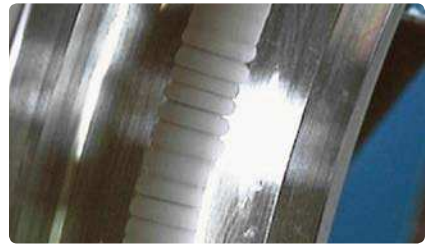


Fig. 68

Left: ball with dull colour caused by current leakage
Right: normal ball
ISO classification: Current leakage



Fig. 69

Burnt grease on the cage bars
ISO classification: Current leakage





Maintenance support

Introduction	326
Training	326
SKF Reliability Maintenance Institute	326
Classroom training	326
Customized training	326
SKF Reliability Maintenance Institute online	327
SKF @ptitude Exchange	327
SKF @ptitude Decision Support	327
Maintenance strategy review	328
SKF Client Needs Analysis	328
Integrated maintenance solutions	329
Energy and sustainability management	329
SKF Energy Monitoring Service	329
Shopfloor Awareness Cards	330
Mechanical maintenance services	330
Remanufacturing and refurbishment	331
SKF remanufacturing services	331
SKF machine tool precision services	331
SKF Authorized Distributors	331
SKF Certified Maintenance Partners	331
SKF Certified Electric Motor Rebuilders	331

Introduction

To support you further in your machinery maintenance efforts, SKF offers a comprehensive range of support services.

This chapter provides an overview of these services. Full details can be found online at www.skf.com/services and/or www.aptitudexchange.com.

Training

Providing the right training makes sure that you and your staff are properly trained and have the right skills to maintain and manage your plant machinery assets, reducing maintenance costs and improving plant reliability and productivity.

SKF offers training options that range from tailored face-to-face on-site training, to online training solutions that can be taken at times that suit you, and at your own pace.

A comprehensive portfolio of training courses are available, covering machine reliability, from basics through to expert level.

No matter what industry you operate in, or what machinery you use, SKF can help show you how to improve the maintenance of your assets.

SKF Reliability Maintenance Institute

The SKF Reliability Maintenance Institute (RMI) offers a comprehensive suite of training courses for different skill levels, with a training portfolio that covers most aspects of machine maintenance and reliability, from bearing basics and lubrication to maintenance strategies and asset management.

Classroom training

Traditional RMI classroom courses, delivered by specialized instructors, are held at various SKF training facilities but can also be held on-site, on request. On-site training brings the instructor and the expertise into your plant so you can apply the training directly to your equipment.

Most courses include a certification test. Those participants who successfully pass the test will become SKF Certified in that course.

Customized training

SKF can create customized training programmes for individual companies according to their specific requirements. For employee skills, process or equipment training, RMI specialists can perform task and skills analysis to evaluate training needs, develop course materials, and implement a training schedule.



SKF Reliability Maintenance Institute online

The online area of the SKF Reliability Maintenance Institute (RMI) offers an expanding portfolio of introductory level e-learning courses covering a range of topics. This enables self-paced learning to be enjoyed by the participants at their own convenience. The RMI online enables learners to collaborate with each other and the course tutors. The “ask the expert” functionality provides the participant with direct access to an extensive network of SKF subject matter experts, maximizing the effectiveness of the learning experience.

Similar to the classroom courses, the online courses are structured to reflect the Asset Efficiency Optimization process from SKF. On completion of a course, each participant can assess what they have learned by taking a test. Certificates are available for printing to all successful participants.

SKF @ptitude Exchange

SKF @ptitude Exchange is SKF’s online knowledge source for maintenance and reliability expertise, focusing on three key areas:

- Asset management, e.g. maintenance optimization and logistics
- Mechanical maintenance, e.g. balancing, alignment and lubrication
- Reliability engineering, e.g. predictive maintenance, vibration analysis and inspection techniques

The SKF @ptitude Exchange website serves as the SKF Reliability Maintenance Institute’s library, providing a wealth of high quality technical information to reinforce the course tuition. White papers, articles, tutorials and much more are available to registered users, at a fee, as well as access to many programs and interactive services including:

- SKF Bearing Inspector, to assist in bearing damage analysis
- LubeSelect, for lubricant selection
- LuBase, for lubricant-specific data
- SKF.com/mount, for detailed mounting instructions of bearings, housings and units

- @ptitude Exchange Forum, for discussions with maintenance and reliability specialists

A subscription is required for some of the programs.

SKF @ptitude Decision Support

The SKF @ptitude Decision Support is a knowledge management system that incorporates today’s most advanced technologies to integrate data from multiple sources into an easy to use reliability maintenance application. It enhances the user’s ability to make the right decision at the right time, providing a structured approach to capturing and applying knowledge.

Maintenance strategy review

How and where can I improve plant performance? Should I better align my plant with industry benchmarks? How can I make sure of continual improvement in my plant's maintenance processes?

These are good questions. But finding the right answers and implementing strategies to address these issues can be daunting. With daily operational challenges and time constraints, identifying and achieving improvement opportunities may seem impossible. But SKF can help.

To be successful, you must make sure that your maintenance strategy and its execution are closely aligned to achieve the benefits you expect. Together with your facility's team, your SKF consultant can provide the tools, techniques, coaching and guidance to accomplish this.

SKF can provide a review of your maintenance strategy, benchmarking against your industry, and producing a report that shows you the way forward. As you decide how to make improvements and implement these recommendations, SKF can help you at each stage along the way, providing the knowledge, technologies and training that your plant's staff need to deliver the returns you want.

Alternatively, SKF can implement and deliver your machinery maintenance programme on your behalf, providing the expertise, manpower and equipment needed to deliver on mutually agreed results.

SKF Client Needs Analysis

A starting point in assessing the effectiveness of your current maintenance strategy can be the implementation of an SKF Client Needs Analysis. This service can focus on either your asset management strategies, and/or your energy efficiency and sustainability related issues.

An integrated reliability and risk-based asset management strategy starts with an understanding of where you are today, and where you need to be to attain optimum performance. The SKF Client Needs Analysis enables this understanding, combining our experience in reliability-focused maintenance with your knowledge of plant conditions. The goal is to provide useful, actionable information to help you focus on credible performance improvement opportunities.



The SKF Client Needs Analysis provides a snapshot of your present plant's situation, and also considers industry-specific aspects of maintenance and reliability to create a unique, needs-based analysis.

Once we know how your reliability maintenance processes are currently working, we then help devise a roadmap to meet your most pressing challenges.

Integrated maintenance solutions

The basis of an Integrated maintenance solution (IMS) is a partnership where SKF is responsible for creating and implementing your asset management strategy with the ultimate goal of increasing the reliability and profitability of your plant. With an IMS agreement, SKF becomes an integral part of your operational team. We supply bearings, seals and lubricants and manage the maintenance of your machinery. We collaborate with you, combining our in-depth experience and expertise in asset management and knowledge of rotating equipment to reduce the Total Cost of Ownership of your assets.

Benefits at a glance include:

- increase machine reliability and uptime
- manage Total Cost of Ownership and control your maintenance costs
- upgrade maintenance operations, reliability and craft skills
- avoid capital expenses for technology and inventory
- achieve timely supply and control your costs for MRO (maintenance, repair and operations) components
- leverage SKF engineering resources

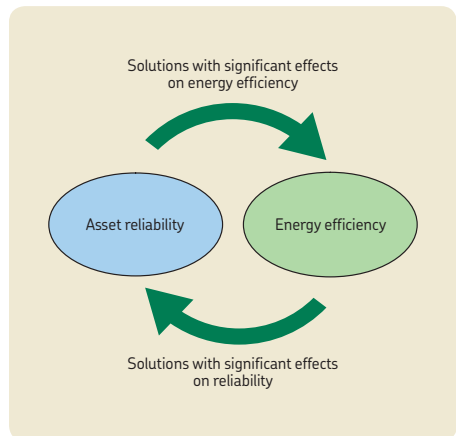


Energy and sustainability management

Energy efficiency can provide an indication of reliability in plant machinery assets, such as pumps. However, while energy efficiency can be an indicator of reliability, it cannot be used to predict and detect specific maintenance issues. As a result, energy monitoring and condition monitoring programmes from SKF have a complementary relationship, and provide maximum benefits and cost savings when deployed in parallel.

SKF Energy Monitoring Service

SKF offers energy monitoring services for both compressed air and pump systems. Both services can help you to identify opportunities to reduce energy bills and improve your environmental performance. Typical benefits include:



Maintenance support

- cost savings – through identification of opportunities for system optimization and energy reduction
- expert programme management – professional data collection and analysis with recommendations for actions to improve system efficiency
- best practices – combining SKF Condition Monitoring technologies and route based inspections with industry accepted best practices for monitoring and calculating energy and CO₂ emissions
- ODR based – applying proven Operator Driven Reliability tools and methodology to engage plant operators and management staff in energy awareness and energy management activities
- integration – combining energy data with existing condition monitoring programmes for data screening, analysis and reporting
- flexible resourcing – executed using internal staff trained by SKF, or by SKF under a field service contract

Shopfloor Awareness Cards

United States Department of Energy experience suggests that a comprehensive awareness programme can reduce energy consumption by 5% without substantial capital investment.

The energy and sustainability Shopfloor Awareness Cards from SKF give front-line managers the opportunity and tools to engage with their teams in a discussion about energy and sustainability in a manner that encourages feedback and ideas for savings every time they meet.

Just as many companies start every gathering with a safety discussion, the Shopfloor Awareness Cards enable every meeting to have an “energy minute”. The cards present specific energy and sustainability topics in non-technical terms that make the issues understandable and approachable by operating staff. They are not intended to be used as a comprehensive training programme but rather to keep energy and sustainability issues in front of all employees on a regular basis.

Mechanical maintenance services

As equipment becomes more complex to maintain, due to technology advances and environmental and safety laws, more companies need help with their maintenance operations. SKF offers a broad range of mechanical maintenance services, helping customers achieve their maintenance goals. These include:

- machine installation
- precision alignment
- 3D measurement
- on-site machining
- precision balancing
- bearing mounting and dismantling
- lubrication solutions



Remanufacturing and refurbishment

SKF remanufacturing services

Remanufacturing can extend the service life of your bearings, reducing your maintenance costs and reducing environmental impact. SKF has a global network of state-of-the-art service centres, giving you access to our world-class bearing remanufacturing capabilities. We use the same quality materials, methods, and machinery to rework bearings that we use to manufacture them, giving you the peace of mind that your bearings and related equipment, such as housings, are being treated with the same level of quality, working processes and knowledge, regardless of where in the world you are located.

To determine whether your bearings are suitable for remanufacturing, contact your local SKF representative.

SKF machine tool precision services

SKF is the world's largest provider of spindle reconditioning services, providing a wide range of highly specialized expert services – from engineering upgrades to spindle analysis, reconditioning, and replacement.

SKF Authorized Distributors

SKF takes great care in developing and supporting its network of distributors to enable them to bring more value to their customers. This means that users of SKF products can depend on receiving fast delivery, knowledgeable advice, and comprehensive services from their SKF distributor.

Our global distributor network provides availability of SKF products and services virtually anywhere in the world. The combination of SKF global knowledge and local distributor experience is a powerful resource for those involved in the maintenance and reliability of industrial machinery.

To find your local SKF Authorized Distributor, check your local country website or visit www.skf.com.



SKF Certified Maintenance Partners

SKF Certified Maintenance Partners are SKF Authorized Distributors who have received advanced machine reliability training. They can help to monitor machine operation, predict machine failures and uncover hidden cost-saving opportunities.

SKF Certified Electric Motor Rebuilders

SKF Certified Electric Motor Rebuilders have the expertise, resources and precise procedures to help achieve longer, more reliable motor service life along with enhanced performance and profitability. To earn the prestigious title of SKF Certified Electric Motor Rebuilder, electric motor shops must meet exacting requirements.

Appendices

Appendix A: Recommended fits	334
A-1 Fits for solid steel shafts (for radial bearings with a cylindrical bore)	334
A-2 Fits for solid steel shafts (for thrust bearings)	336
A-3 Fits for one-piece cast iron and steel housings (for radial bearings)	336
A-4 Fits for split or one-piece cast iron and steel housings (for radial bearings)	337
A-5 Fits for cast iron and steel housings (for thrust bearings)	337
Appendix B: Shaft and housing tolerances	338
B-1 Shaft tolerances and resultant fits (metric)	338
B-2 Housing tolerances and resultant fits (metric)	350
B-3 Shaft tolerances and resultant fits (inch)	360
B-4 Housing tolerances and resultant fits (inch)	372
B-5 Modified shaft diameter deviations for use with inch bearings	382
B-6 Modified housing bore diameter deviations for use with inch bearings	383
B-7 Shaft diameter and form tolerances for sleeve mounting	384
Appendix C: ISO tolerance grades	385
Appendix D: Accuracy of bearing seats	386
D-1 Accuracy of form and position of bearing seats	386
D-2 Surface roughness of bearing seats	387
D-3 Dimensions for relieved fillets	387
Appendix E: Bearing internal clearance	388
E-1 Radial internal clearance of deep groove ball bearings	388
E-2 Axial internal clearance of universally matchable angular contact ball bearings	389
E-3 Axial preload of universally matchable angular contact ball bearings	389
E-4 Axial internal clearance of double row angular contact ball bearings	390
E-5 Axial internal clearance of four-point contact ball bearings	391
E-6 Radial internal clearance of self-aligning ball bearings	392
E-7 Radial internal clearance of cylindrical and needle roller bearings	393
E-8 Axial internal clearance of NUP cylindrical roller bearings	394
E-9 Axial internal clearance of NJ + HJ cylindrical roller bearings	395
E-10 Axial internal clearance of matched single row metric tapered roller bearings	396
E-11 Radial internal clearance of spherical roller bearings with a cylindrical bore	397
E-12 Radial internal clearance of spherical roller bearings with a tapered bore	398
E-13 Radial internal clearance of CARB toroidal roller bearings with a cylindrical bore	399
E-14 Radial internal clearance of CARB toroidal roller bearings with a tapered bore	400
E-15 Radial internal clearance of Y-bearings	401

Appendix F: Recommended values for axial drive-up, reduction of radial internal clearance and lock nut tightening angle.	402
F-1 Drive-up data for self-aligning ball bearings with a tapered bore	402
F-2 Drive-up data for spherical roller bearings with a tapered bore	403
F-3 Drive-up data for CARB toroidal roller bearings with a tapered bore	404
Appendix G: Recommended values for preparing associated components for the oil injection method.	405
G-1 Recommended dimensions for oil supply ducts and distribution grooves	405
G-2 Design and recommended dimensions for threaded holes for connecting oil supply	405
Appendix H: Guideline values for the SKF Drive-up Method.	406
H-1 Guideline values for requisite oil pressure and axial displacement for mounting self-aligning ball bearings	406
H-2 Guideline values for requisite oil pressure and axial displacement for mounting spherical roller bearings.	407
H-3 Guideline values for requisite oil pressure and axial displacement for mounting CARB toroidal roller bearings.	412
Appendix I: Oil viscosity equivalents and ISO viscosity grades	414
I-1 Viscosity equivalents	414
I-2 ISO viscosity grades	415
Appendix J: Overview of SKF mounting tools and products.	416
Appendix K: Overview of SKF alignment equipment	419
Appendix L: Overview of SKF lubrication tools and products.	420
Appendix M: SKF bearing greases and grease selection chart.	423
Appendix N: Overview of SKF basic condition monitoring instruments	432
Appendix O: Overview of SKF dismantling tools and products	435
Appendix P: Unit conversion table	437

Fits for solid steel shafts (for radial bearings with a cylindrical bore)

Conditions	Examples	Shaft diameter, mm				Tolerance class
		Ball bearings ¹⁾	Cylindrical roller bearings	Tapered roller bearings	CARB and spherical roller bearings	
Rotating inner ring load or direction of load indeterminate						
Light and variable loads ($P \leq 0,05 C$)	Conveyors, lightly loaded gearbox bearings	≤ 17	–	–	–	js5 (h5) ²⁾
		(17) to 100	≤ 25	≤ 25	–	j6 (j5) ²⁾
		(100) to 140	(25) to 60 (60) to 140	(25) to 60 (60) to 140	–	k6 m6
Normal to heavy loads ($P > 0,05 C$)	General bearing applications, electric motors, turbines, pumps, gears, wood-working machines, wind turbines	≤ 10	–	–	–	js5
		(10) to 17	–	–	–	j5 (j5) ²⁾
		(17) to 100	–	–	< 25	k5 ³⁾
		–	≤ 30	≤ 40	–	k6
		(100) to 140	(30) to 50	–	25 to 40	m5
		(140) to 200	–	(40) to 65	–	m6
		–	(50) to 65	–	(40) to 60	n5 ⁴⁾
		(200) to 500	(65) to 100 (100) to 280	(65) to 200 (200) to 360	(60) to 100 (100) to 200	n6 ⁴⁾ p6 ⁵⁾ p7 ⁴⁾
> 500	–	–	–	r6 ⁴⁾		
–	(280) to 500 > 500	(360) to 500 > 500	(200) to 500 > 500	r7 ⁴⁾		
Heavy to very heavy loads and shock loads under difficult operating conditions ($P > 0,1 C$)	Axleboxes for heavy railway vehicles, traction motors, rolling mills	–	(50) to 65	–	(50) to 70	n5 ⁴⁾
		–	(65) to 85	(50) to 110	–	n6 ⁴⁾
		–	(85) to 140	(110) to 200	(70) to 140	p6 ⁶⁾
		–	(140) to 300	(200) to 500	(140) to 280	r6 ⁷⁾
		–	(300) to 500 > 500	– > 500	(280) to 400 > 400	s6 _{min} ± IT6/2 ⁶⁾ ⁸⁾ s7 _{min} ± IT7/2 ⁶⁾ ⁸⁾
High demands on running accuracy with light loads ($P \leq 0,05 C$) ¹⁰⁾	Machine tools	8 to 240	–	–	–	js4
		–	25 to 40	25 to 40	–	js4 (j5) ⁹⁾
		–	(40) to 140	(40) to 140	–	k4 (k5) ⁹⁾
		–	(140) to 200 (200) to 500	(140) to 200 (200) to 500	–	m5 n5
Stationary inner ring load						
Easy axial displacement of inner ring on shaft desirable	Wheels on non-rotating axles					g6 ¹¹⁾
Easy axial displacement of inner ring on shaft unnecessary	Tension pulleys, rope sheaves					h6
Axial loads only						
Bearing applications of all kinds		≤ 250	–	≤ 250	≤ 250	j6
		> 250	–	> 250	> 250	js6

- ¹⁾ Ball bearings under normal-to-heavy loads ($P > 0,05 C$) often require greater than Normal radial clearance when the shaft tolerance classes listed above are used. If radial clearance is greater than Normal but the operating conditions require tighter fits to prevent the inner ring from turning (creeping), use the tolerance classes listed below:
- k4 for shaft diameters 10 to 17 mm
 - k5 for shaft diameters (17) to 25 mm
 - m5 for shaft diameters (25) to 140 mm
 - n6 for shaft diameters (140) to 300 mm
 - p6 for shaft diameters (300) to 500 mm
- For additional information, contact the SKF application engineering service.
- ²⁾ The tolerance class in brackets applies to stainless steel bearings.
- ³⁾ For stainless steel bearings within the diameter range 17 to 30 mm, tolerance class j5 applies.
- ⁴⁾ Bearings with radial internal clearance greater than Normal may be necessary.
- ⁵⁾ Bearings with radial internal clearance greater than Normal are recommended when $d \leq 150$ mm. When $d > 150$ mm, bearings with radial internal clearance greater than Normal might be necessary.
- ⁶⁾ Bearings with radial internal clearance greater than Normal are recommended.
- ⁷⁾ Bearings with radial internal clearance greater than Normal might be necessary. For cylindrical roller bearings, radial internal clearance greater than Normal is recommended.
- ⁸⁾ For tolerance class values, visit www.skf.com/bearings or contact the SKF application engineering service.
- ⁹⁾ The tolerance class in brackets apply to tapered roller bearings. For lightly loaded tapered roller bearings adjusted via the inner ring, js5 or js6 tolerance class should be used.
- ¹⁰⁾ For high demands on running accuracy, bearings with higher precision than Normal are required. The bore and outside diameter tolerances of these bearings are tighter, which has an influence on the probable fits. To obtain relevant values, contact the SKF application engineering service.
- ¹¹⁾ Tolerance class f6 can be selected for large bearings to accommodate easy axial displacement.

Fits for solid steel shafts (for thrust bearings)

Conditions	Shaft diameter, mm	Tolerance class
Axial loads only		
Thrust ball bearings	–	h6
Cylindrical roller thrust bearings	–	h6 (h8)
Cylindrical roller and cage thrust assemblies	–	h8
Combined radial and axial loads acting on spherical roller thrust bearings		
Stationary load on shaft washer	≤ 250 > 250	j6 js6
Rotating load on shaft washer, or direction of load indeterminate	≤ 200 (200) to 400 > 400	k6 m6 n6

Fits for one-piece cast iron and steel housings (for radial bearings)

Conditions	Examples	Tolerance class ¹⁾	Displacement of outer ring
Rotating outer ring load			
Heavy loads on bearings in thin-walled housings, heavy shock loads (P > 0,1 C)	Roller bearing wheel hubs, big-end bearings	P7	Cannot be displaced
Normal to heavy loads (P > 0,05 C)	Ball bearing wheel hubs, big-end bearings, crane travel wheels	N7	Cannot be displaced
Light and variable loads (P ≤ 0,05 C)	Conveyor rollers, rope sheaves, belt tensioner pulleys	M7	Cannot be displaced
Direction of load indeterminate			
Heavy shock loads	Electric traction motors	M7	Cannot be displaced
Normal to heavy loads (P > 0,05 C), axial displacement of outer ring unnecessary	Electric motors, pumps, crankshaft bearings	K7	Cannot be displaced as a rule
Accurate or quiet running²⁾			
Ball bearings	Small electric motors	J6 ³⁾	Can be displaced
Tapered roller bearings	When adjusted via the outer ring	JS5	–
	Axially located outer ring	K5	–
	Rotating outer ring load	M5	–

¹⁾ For ball bearings when D ≤ 100 mm, tolerance grade IT6 is often preferable and is recommended for bearings with thin-walled rings, e.g. in the 7, 8 or 9 diameter series. For these series, cylindricity tolerance grade IT4 is also recommended.

²⁾ For high- and super-precision bearings to tolerance class P5 or better, other recommendations apply. For additional information, visit www.skf.com/bearings.

³⁾ When easy axial displacement is required, use tolerance class H6.

Appendix A-4

Fits for split or one-piece cast iron and steel housings (for radial bearings)

Conditions	Examples	Tolerance class ¹⁾	Displacement of outer ring
Direction of load indeterminate			
Light to normal loads ($P \leq 0,1 C$) axial displacement of outer ring desirable	Medium-size electric motors and generators, pumps, crankshaft bearings	J7	Can be displaced as a rule, but some (induced) axial force might occur
Stationary outer ring load			
Loads of all kinds	General engineering, railway axleboxes	H7 ²⁾	Can be displaced as a rule
Light to normal loads ($P \leq 0,1 C$) with simple working conditions	General engineering	H8	Can be displaced
Thermal expansion of the shaft	Drying cylinders, large electrical machines with spherical roller bearings	G7 ³⁾	Can be displaced

¹⁾ For ball bearings when $D \leq 100$ mm, tolerance grade IT6 is often preferable and is recommended for bearings with thin-walled rings, e.g. in the 7, 8 or 9 diameter series. For these series, cylindricity tolerance grade IT4 is also recommended.

²⁾ For large bearings ($D > 250$ mm) or temperature differences between the outer ring and housing > 10 °C, tolerance class G7 should be used instead of tolerance class H7.

³⁾ For large bearings ($D > 250$ mm) or temperature differences between the outer ring and housing > 10 °C, tolerance class F7 should be used instead of tolerance class G7.

Appendix A-5

Fits for cast iron and steel housings (for thrust bearings)

Conditions	Tolerance class	Remarks
Axial loads only		
Thrust ball bearings	H8	For less accurate bearing arrangements there can be a radial clearance of up to $0,001 D$
Cylindrical roller thrust bearings	H7 (H9)	
Cylindrical roller and cage thrust assemblies	H10	
Spherical roller thrust bearings where separate bearings provide radial location	–	Housing washer must be fitted with adequate radial clearance so that no radial load whatsoever can act on the thrust bearings
Combined radial and axial loads on spherical roller thrust bearings		
Stationary load on housing washer	H7	For additional information, visit www.skf.com/bearings
Rotating load on housing washer	M7	

Shaft tolerances and resultant fits (metric)



Shaft Nominal diameter d		Bearing Bore diameter tolerance Δ_{dmp}		Deviations of shaft diameter, resultant fits																													
				Tolerance classes																													
				f5	f6	g5	g6	h5																									
				Deviations (shaft diameter)																													
				Theoretical interference (-)/clearance (+)																													
				Probable interference (-)/clearance (+)																													
over	incl.	low	high	μm																													
mm		μm		μm																													
-	3	-8	0	-6	-10	-6	-12	-2	-6	-2	-8	0	-4	-2	+10	-2	+12	-6	+6	-6	+8	-8	+4	-1	+9	0	+10	-5	+5	-4	+6	-7	+3
3	6	-8	0	-10	-15	-10	-18	-4	-9	-4	-12	0	-5	+2	+15	+2	+18	-4	+9	-4	+12	-8	+5	+3	+14	+4	+16	-3	+8	-2	+10	-7	+4
6	10	-8	0	-13	-19	-13	-22	-5	-11	-5	-14	0	-6	+5	+19	+5	+22	-3	+11	-3	+14	-8	+6	+7	+17	+7	+20	-1	+9	-1	+12	-6	+4
10	18	-8	0	-16	-24	-16	-27	-6	-14	-6	-17	0	-8	+8	+24	+8	+27	-2	+14	-2	+17	-8	+8	+10	+22	+10	+25	0	+12	0	+15	-6	+6
18	30	-10	0	-20	-29	-20	-33	-7	-16	-7	-20	0	-9	+10	+29	+10	+33	-3	+16	-3	+20	-10	+9	+12	+27	+13	+30	-1	+14	0	+17	-8	+7
30	50	-12	0	-25	-36	-25	-41	-9	-20	-9	-25	0	-11	+13	+36	+13	+41	-3	+20	-3	+25	-12	+11	+16	+33	+17	+37	0	+17	+1	+21	-9	+8
50	80	-15	0	-30	-43	-30	-49	-10	-23	-10	-29	0	-13	+15	+43	+15	+49	-5	+23	-5	+29	-15	+13	+19	+39	+19	+45	-1	+19	-1	+25	-11	+9
80	120	-20	0	-36	-51	-36	-58	-12	-27	-12	-34	0	-15	+16	+51	+16	+58	-8	+27	-8	+34	-20	+15	+21	+46	+22	+52	-3	+22	-2	+28	-15	+10
120	180	-25	0	-43	-61	-43	-68	-14	-32	-14	-39	0	-18	+18	+61	+18	+68	-11	+32	-11	+39	-25	+18	+24	+55	+25	+61	-5	+26	-4	+32	-19	+12
180	250	-30	0	-50	-70	-50	-79	-15	-35	-15	-44	0	-20	+20	+70	+20	+79	-15	+35	-15	+44	-30	+20	+26	+64	+28	+71	-9	+29	-7	+36	-24	+14
250	315	-35	0	-56	-79	-56	-88	-17	-40	-17	-49	0	-23	+21	+79	+21	+88	-18	+40	-18	+49	-35	+23	+29	+71	+30	+79	-10	+32	-9	+40	-27	+15
315	400	-40	0	-62	-87	-62	-98	-18	-43	-18	-54	0	-25	+22	+87	+22	+98	-22	+43	-22	+54	-40	+25	+30	+79	+33	+87	-14	+35	-11	+43	-32	+17
400	500	-45	0	-68	-95	-68	-108	-20	-47	-20	-60	0	-27	+23	+95	+23	+108	-25	+47	-25	+60	-45	+27	+32	+86	+35	+96	-16	+38	-13	+48	-36	+18

Shaft tolerances and resultant fits (metric)



Shaft Nominal diameter d		Bearing Bore diameter tolerance Δ_{dmp}		Deviations of shaft diameter, resultant fits Tolerance classes									
				f5		f6		g5		g6		h5	
				Deviations (shaft diameter)									
				Theoretical interference (-)/clearance (+)									
				Probable interference (-)/clearance (+)									
over	incl.	low	high	μm									
mm		μm		μm									
500	630	-50	0	-76	-104	-76	-120	-22	-50	-22	-66	0	-28
				+26	+104	+26	+120	-28	+50	-28	+66	-50	+28
				+36	+94	+39	+107	-18	+40	-15	+53	-40	+18
630	800	-75	0	-80	-112	-80	-130	-24	-56	-24	-74	0	-32
				+5	+112	+5	+130	-51	+56	-51	+74	-75	+32
				+17	+100	+22	+113	-39	+44	-34	+57	-63	+20
800	1 000	-100	0	-86	-122	-86	-142	-26	-62	-26	-82	0	-36
				-14	+122	-14	+142	-74	+62	-74	+82	-100	+36
				0	+108	+6	+122	-60	+48	-54	+62	-86	+22
1 000	1 250	-125	0	-98	-140	-98	-164	-28	-70	-28	-94	0	-42
				-27	+140	-27	+164	-97	+70	-97	+94	-125	+42
				-10	+123	-3	+140	-80	+53	-73	+70	-108	+25
1 250	1 600	-160	0	-110	-160	-110	-188	-30	-80	-30	-108	0	-50
				-50	+160	-50	+188	-130	+80	-130	+108	-160	+50
				-29	+139	-20	+158	-109	+59	-100	+78	-139	+29
1 600	2 000	-200	0	-120	-180	-120	-212	-32	-92	-32	-124	0	-60
				-80	+180	-80	+212	-168	+92	-168	+124	-200	+60
				-55	+155	-45	+177	-143	+67	-133	+89	-175	+35

Shaft tolerances and resultant fits (metric)



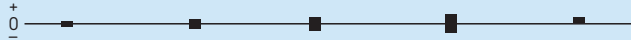
Shaft		Bearing		Deviations of shaft diameter, resultant fits									
Nominal diameter d		Bore diameter tolerance Δ _{dmp}		Tolerance classes									
				h6		h8		h9		j5		j6	
				Deviations (shaft diameter)									
				Theoretical interference (-)/clearance (+)									
				Probable interference (-)/clearance (+)									
over	incl.	low	high	μm									
mm		μm		μm									
-	3	-8	0	0	-6	0	-14	0	-25	+2	-2	+4	-2
				-8	+6	-8	+14	-8	+25	-10	+2	-12	+2
				-6	+4	-6	+12	-5	+22	-9	+1	-10	0
3	6	-8	0	0	-8	0	-18	0	-30	+3	-2	+6	-2
				-8	+8	-8	+18	-8	+30	-11	+2	-14	+2
				-6	+6	-5	+15	-5	+27	-10	+1	-12	0
6	10	-8	0	0	-9	0	-22	0	-36	+4	-2	+7	-2
				-8	+9	-8	+22	-8	+36	-12	+2	-15	+2
				-6	+7	-5	+19	-5	+33	-10	0	-13	0
10	18	-8	0	0	-11	0	-27	0	-43	+5	-3	+8	-3
				-8	+11	-8	+27	-8	+43	-13	+3	-16	+3
				-6	+9	-5	+24	-5	+40	-11	+1	-14	+1
18	30	-10	0	0	-13	0	-33	0	-52	+5	-4	+9	-4
				-10	+13	-10	+33	-10	+52	-15	+4	-19	+4
				-7	+10	-6	+29	-6	+48	-13	+2	-16	+1
30	50	-12	0	0	-16	0	-39	0	-62	+6	-5	+11	-5
				-12	+16	-12	+39	-12	+62	-18	+5	-23	+5
				-8	+12	-7	+34	-7	+57	-15	+2	-19	+1
50	80	-15	0	0	-19	0	-46	0	-74	+6	-7	+12	-7
				-15	+19	-15	+46	-15	+74	-21	+7	-27	+7
				-11	+15	-9	+40	-9	+68	-17	+3	-23	+3
80	120	-20	0	0	-22	0	-54	0	-87	+6	-9	+13	-9
				-20	+22	-20	+54	-20	+87	-26	+9	-33	+9
				-14	+16	-12	+46	-12	+79	-21	+4	-27	+3
120	180	-25	0	0	-25	0	-63	0	-100	+7	-11	+14	-11
				-25	+25	-25	+63	-25	+100	-32	+11	-39	+11
				-18	+18	-15	+53	-15	+90	-26	+5	-32	+4
180	250	-30	0	0	-29	0	-72	0	-115	+7	-13	+16	-13
				-30	+29	-30	+72	-30	+115	-37	+13	-46	+13
				-22	+21	-18	+60	-17	+102	-31	+7	-38	+5
250	315	-35	0	0	-32	0	-81	0	-130	+7	-16	+16	-16
				-35	+32	-35	+81	-35	+130	-42	+16	-51	+16
				-26	+23	-22	+68	-20	+115	-34	+8	-42	+7
315	400	-40	0	0	-36	0	-89	0	-140	+7	-18	+18	-18
				-40	+36	-40	+89	-40	+140	-47	+18	-58	+18
				-29	+25	-25	+74	-23	+123	-39	+10	-47	+7
400	500	-45	0	0	-40	0	-97	0	-155	+7	-20	+20	-20
				-45	+40	-45	+97	-45	+155	-52	+20	-65	+20
				-33	+28	-28	+80	-26	+136	-43	+11	-53	+8

Shaft tolerances and resultant fits (metric)



Shaft Nominal diameter d		Bearing Bore diameter tolerance Δ_{dmp}		Deviations of shaft diameter, resultant fits Tolerance classes									
				h6		h8		h9		j5		j6	
				Deviations (shaft diameter)									
				Theoretical interference (-)/clearance (+)									
				Probable interference (-)/clearance (+)									
over	incl.	low	high	μm									
mm		μm		μm									
500	630	-50	0	0	-44	0	-110	0	-175	-	-	+22	-22
				-50	+44	-50	+110	-50	+175	-	-	-72	+22
				-37	+31	-31	+91	-29	+154	-	-	-59	+9
630	800	-75	0	0	-50	0	-125	0	-200	-	-	+25	-25
				-75	+50	-75	+125	-75	+200	-	-	-100	+25
				-58	+33	-48	+98	-45	+170	-	-	-83	+8
800	1 000	-100	0	0	-56	0	-140	0	-230	-	-	+28	-28
				-100	+56	-100	+140	-100	+230	-	-	-128	+28
				-80	+36	-67	+107	-61	+191	-	-	-108	+8
1 000	1 250	-125	0	0	-66	0	-165	0	-260	-	-	+33	-33
				-125	+66	-125	+165	-125	+260	-	-	-158	+33
				-101	+42	-84	+124	-77	+212	-	-	-134	+9
1 250	1 600	-160	0	0	-78	0	-195	0	-310	-	-	+39	-39
				-160	+78	-160	+195	-160	+310	-	-	-199	+39
				-130	+48	-109	+144	-100	+250	-	-	-169	+9
1 600	2 000	-200	0	0	-92	0	-230	0	-370	-	-	+46	-46
				-200	+92	-200	+230	-200	+370	-	-	-246	+46
				-165	+57	-138	+168	-126	+296	-	-	-211	+11

Shaft tolerances and resultant fits (metric)



Shaft Nominal diameter d		Bearing Bore diameter tolerance Δ_{dmp}		Deviations of shaft diameter, resultant fits Tolerance classes									
				js4	js5	js6	js7	k4					
				Deviations (shaft diameter)									
				Theoretical interference (-)/clearance (+)									
				Probable interference (-)/clearance (+)									
over	incl.	low	high	µm									
mm		µm											
-	3	-8	0	+1,5	-1,5	+2	-2	+3	-3	+5	-5	+3	0
				-9,5	+1,5	-10	+2	-11	+3	-13	+5	-11	0
				-8,5	+0,5	-9	+1	-9	+1	-11	+3	-10	-1
3	6	-8	0	+2	-2	+2,5	-2,5	+4	-4	+6	-6	+5	+1
				-10	+2	-10,5	+2,5	-12	+4	-14	+6	-13	-1
				-9	+1	-9	+1	-10	+2	-12	+4	-12	-2
6	10	-8	0	+2	-2	+3	-3	+4,5	-4,5	+7,5	-7,5	+5	+1
				-10	+2	-11	+3	-12,5	+4,5	-15,5	+7,5	-13	-1
				-9	+1	-9	+1	-11	+3	-13	+5	-12	-2
10	18	-8	0	+2,5	-2,5	+4	-4	+5,5	-5,5	+9	-9	+6	+1
				-10,5	+2,5	-12	+4	-13,5	+5,5	-17	+9	-14	-1
				-9,5	+1,5	-10	+2	-11	+3	-14	+6	-13	-2
18	30	-10	0	+3	-3	+4,5	-4,5	+6,5	-6,5	+10,5	-10,5	+8	+2
				-13	+3	-14,5	+4,5	-16,5	+6,5	-20,5	+10,5	-18	-2
				-10,5	+1,5	-12	+2	-14	+4	-17	+7	-16	-4
30	50	-12	0	+3,5	-3,5	+5,5	-5,5	+8	-8	+12,5	-12,5	+9	+2
				-15,5	+3,5	-17,5	+5,5	-20	+8	-24,5	+12,5	-21	-2
				-13,5	+1,5	-15	+3	-16	+4	-20	+8	-19	-4
50	80	-15	0	+4	-4	+6,5	-6,5	+9,5	-9,5	+15	-15	+10	+2
				-19	+4	-21,5	+6,5	-24,5	+9,5	-30	+15	-25	-2
				-15,5	+1,5	-18	+3	-20	+5	-25	+10	-22	-5
80	120	-20	0	+5	-5	+7,5	-7,5	+11	-11	+17,5	-17,5	+13	+3
				-25	+5	-27,5	+7,5	-31	+11	-37,5	+17,5	-33	-3
				-22	+2	-23	+3	-25	+5	-31	+11	-30	-6
120	180	-25	0	+6	-6	+9	-9	+12,5	-12,5	+20	-20	+15	+3
				-31	+6	-34	+9	-37,5	+12,5	-45	+20	-40	-3
				-27	+2	-28	+3	-31	+6	-37	+12	-36	-7
180	250	-30	0	+7	-7	+10	-10	+14,5	-14,5	+23	-23	+18	+4
				-37	+7	-40	+10	-44,5	+14,5	-53	+23	-48	-4
				-32	+2	-34	+4	-36	+6	-43	+13	-43	-9
250	315	-35	0	+8	-8	+11,5	-11,5	+16	-16	+26	-26	+20	+4
				-4	+8	-46,5	+11,5	-51	+16	-61	+26	-55	-4
				-37	+2	-39	+4	-42	+7	-49	+14	-49	-10
315	400	-40	0	+9	-9	+12,5	-12,5	+18	-18	+28,5	-28,5	+22	+4
				-49	+9	-52,5	+12,5	-58	+18	-68,5	+28,5	-62	-4
				-42	+2	-44	+4	-47	+7	-55	+15	-55	-11
400	500	-45	0	+10	-10	+13,5	-13,5	+20	-20	+31,5	-31,5	+25	+5
				-55	+10	-58,5	+13,5	-65	+20	-76,5	+31,5	-70	-5
				-48	+3	-49	+4	-53	+8	-62	+17	-63	-12

Shaft tolerances and resultant fits (metric)




Shaft Nominal diameter d		Bearing Bore diameter tolerance Δ_{dmp}		Deviations of shaft diameter, resultant fits									
				Tolerance classes									
				js4	js5	js6	js7	k4					
				Deviations (shaft diameter)									
				Theoretical interference (-)/clearance (+)									
				Probable interference (-)/clearance (+)									
over	incl.	low	high	μm									
mm		μm		μm									
500	630	-50	0	-	-	+14	-14	+22	-22	+35	-35	-	-
				-	-	-64	+14	-72	+22	-85	+35	-	-
				-	-	-54	+4	-59	+9	-69	+19	-	-
630	800	-75	0	-	-	+16	-16	+25	-25	+40	-40	-	-
				-	-	-91	+16	-100	+25	-115	+40	-	-
				-	-	-79	+4	-83	+8	-93	+18	-	-
800	1 000	-100	0	-	-	+18	-18	+28	-28	+45	-45	-	-
				-	-	-118	+18	-128	+28	-145	+45	-	-
				-	-	-104	+4	-108	+8	-118	+18	-	-
1 000	1 250	-125	0	-	-	+21	-21	+33	-33	+52	-52	-	-
				-	-	-146	+21	-158	+33	-177	+52	-	-
				-	-	-129	+4	-134	+9	-145	+20	-	-
1 250	1 600	-160	0	-	-	+25	-25	+39	-39	+62	-62	-	-
				-	-	-185	+25	-199	+39	-222	+62	-	-
				-	-	-164	+4	-169	+9	-182	+22	-	-
1 600	2 000	-200	0	-	-	+30	-30	+46	-46	+75	-75	-	-
				-	-	-230	+30	-246	+46	-275	+75	-	-
				-	-	-205	+5	-211	+11	-225	+25	-	-

Shaft tolerances and resultant fits (metric)



Shaft Nominal diameter d		Bearing Bore diameter tolerance Δ_{dmp}		Deviations of shaft diameter, resultant fits																													
				Tolerance classes																													
				k5		k6		m5		m6		n5																					
				Deviations (shaft diameter)																													
				Theoretical interference (-)																													
				Probable interference (-)																													
over	incl.	low	high	μm																													
mm		μm																															
-	3	-8	0	+4	0	+6	0	+6	+2	+8	+2	+8	+4	-12	0	-14	0	-14	-2	-16	-2	-16	-4	-11	-1	-12	-2	-13	-3	-14	-4	-15	-5
3	6	-8	0	+6	+1	+9	+1	+9	+4	+12	+4	+13	+8	-14	-1	-17	-1	-17	-4	-20	-4	-21	-8	-13	-2	-15	-3	-16	-5	-18	-6	-20	-9
6	10	-8	0	+7	+1	+10	+1	+12	+6	+15	+6	+16	+10	-15	-1	-18	-1	-20	-6	-23	-6	-24	-10	-13	-3	-16	-3	-18	-8	-21	-8	-22	-12
10	18	-8	0	+9	+1	+12	+1	+15	+7	+18	+7	+20	+12	-17	-1	-20	-1	-23	-7	-26	-7	-28	-12	-15	-3	-18	-3	-21	-9	-24	-9	-26	-14
18	30	-10	0	+11	+2	+15	+2	+17	+8	+21	+8	+24	+15	-21	-2	-25	-2	-27	-8	-31	-8	-34	-15	-19	-4	-22	-5	-25	-10	-28	-11	-32	-17
30	50	-12	0	+13	+2	+18	+2	+20	+9	+25	+9	+28	+17	-25	-2	-30	-2	-32	-9	-37	-9	-40	-17	-22	-5	-26	-6	-29	-12	-33	-13	-37	-20
50	80	-15	0	+15	+2	+21	+2	+24	+11	+30	+11	+33	+20	-30	-2	-36	-2	-39	-11	-45	-11	-48	-20	-26	-6	-32	-6	-35	-15	-41	-15	-44	-24
80	120	-20	0	+18	+3	+25	+3	+28	+13	+35	+13	+38	+23	-38	-3	-45	-3	-48	-13	-55	-13	-58	-23	-33	-8	-39	-9	-43	-18	-49	-19	-53	-28
120	180	-25	0	+21	+3	+28	+3	+33	+15	+40	+15	+45	+27	-46	-3	-53	-3	-58	-15	-65	-15	-70	-27	-40	-9	-46	-10	-52	-21	-58	-22	-64	-33
180	250	-30	0	+24	+4	+33	+4	+37	+17	+46	+17	+51	+31	-54	-4	-63	-4	-67	-17	-76	-17	-81	-31	-48	-10	-55	-12	-61	-23	-68	-25	-75	-37
250	315	-35	0	+27	+4	+36	+4	+43	+20	+52	+20	+57	+34	-62	-4	-71	-4	-78	-20	-87	-20	-92	-34	-54	-12	-62	-13	-70	-28	-78	-29	-84	-42
315	400	-40	0	+29	+4	+40	+4	+46	+21	+57	+21	+62	+37	-69	-4	-80	-4	-86	-21	-97	-21	-102	-37	-61	-12	-69	-15	-78	-29	-86	-32	-94	-45
400	500	-45	0	+32	+5	+45	+5	+50	+23	+63	+23	+67	+40	-77	-5	-90	-5	-95	-23	-108	-23	-112	-40	-68	-14	-78	-17	-86	-32	-96	-35	-103	-49

Shaft tolerances and resultant fits (metric)




Shaft Nominal diameter d		Bearing Bore diameter tolerance Δ_{dmp}		Deviations of shaft diameter, resultant fits									
				Tolerance classes									
				k5		k6		m5		m6		n5	
				Deviations (shaft diameter)									
				Theoretical interference (-)									
				Probable interference (-)									
over	incl.	low	high	μm									
mm		μm		μm									
500	630	-50	0	+29	0	+44	0	+55	+26	+70	+26	+73	+44
				-78	0	-94	0	-105	-26	-120	-26	-122	-44
				-68	-10	-81	-13	-94	-36	-107	-39	-112	-54
630	800	-75	0	+32	0	+50	0	+62	+30	+80	+30	+82	+50
				-107	0	-125	0	-137	-30	-155	-30	-157	-50
				-95	-12	-108	-17	-125	-42	-138	-47	-145	-62
800	1 000	-100	0	+36	0	+56	0	+70	+34	+90	+34	+92	+56
				-136	0	-156	0	-170	-34	-190	-34	-192	-56
				-122	-14	-136	-20	-156	-48	-170	-54	-178	-70
1 000	1 250	-125	0	+42	0	+66	0	+82	+40	+106	+40	+108	+66
				-167	0	-191	0	-207	-40	-231	-40	-233	-66
				-150	-17	-167	-24	-190	-57	-207	-64	-216	-83
1 250	1 600	-160	0	+50	0	+78	0	+98	+48	+126	+48	+128	+78
				-210	0	-238	0	-258	-48	-286	-48	-288	-78
				-189	-21	-208	-30	-237	-69	-256	-78	-267	-99
1 600	2 000	-200	0	+60	0	+92	0	+118	+58	+150	+58	+152	+92
				-260	0	-292	0	-318	-58	-350	-58	-352	-92
				-235	-25	-257	-35	-293	-83	-315	-93	-327	-117

Shaft tolerances and resultant fits (metric)

Shaft		Bearing		Deviations of shaft diameter, resultant fits										
Nominal diameter d		Bore diameter tolerance Δ _{dmp}		Tolerance classes										
				n6	p6		p7		r6		r7			
over	incl.	low	high	Deviations (shaft diameter)										
				Theoretical interference (-)										
				Probable interference (-)										
mm		μm		μm										
50	80	-15	0	+39	+20	+51	+32	+62	+32	-	-	-	-	-
				-54	-20	-66	-32	-77	-32	-	-	-	-	-
				-50	-24	-62	-36	-72	-38	-	-	-	-	-
80	100	-20	0	+45	+23	+59	+37	+72	+37	+73	+51	+86	+51	
				-65	-23	-79	-37	-92	-37	-93	-51	-106	-51	
				-59	-29	-73	-43	-85	-44	-87	-57	-99	-58	
100	120	-20	0	+45	+23	+59	+37	+72	+37	+76	+54	+89	+54	
				-65	-23	-79	-37	-92	-37	-96	-54	-109	-54	
				-59	-29	-73	-43	-85	-44	-90	-60	-102	-61	
120	140	-25	0	+52	+27	+68	+43	+83	+43	+88	+63	+103	+63	
				-77	-27	-93	-43	-108	-43	-113	-63	-128	-63	
				-70	-34	-86	-50	-100	-51	-106	-70	-120	-71	
140	160	-25	0	+52	+27	+68	+43	+83	+43	+90	+65	+105	+65	
				-77	-27	-93	-43	-108	-43	-115	-65	-130	-65	
				-70	-34	-86	-50	-100	-51	-108	-72	-122	-73	
160	180	-25	0	+52	+27	+68	+43	+83	+43	+93	+68	+108	+68	
				-77	-27	-93	-43	-108	-43	-118	-68	-133	-68	
				-70	-34	-86	-50	-100	-51	-111	-75	-125	-76	
180	200	-30	0	+60	+31	+79	+50	+96	+50	+106	+77	+123	+77	
				-90	-31	-109	-50	-126	-50	-139	-80	-153	-77	
				-82	-39	-101	-58	-116	-60	-128	-85	-143	-87	
200	225	-30	0	+60	+31	+79	+50	+96	+50	+109	+80	+126	+80	
				-90	-31	-109	-50	-126	-50	-139	-80	-156	-80	
				-82	-39	-101	-58	-116	-60	-131	-88	-146	-90	
225	250	-30	0	+60	+31	+79	+50	+96	+50	+113	+84	+130	+84	
				-90	-31	-109	-50	-126	-50	-143	-84	-160	-84	
				-82	-39	-101	-58	-116	-60	-135	-92	-150	-94	
250	280	-35	0	+66	+34	+88	+56	+108	+56	+126	+94	+146	+94	
				-101	-34	-123	-56	-143	-56	-161	-94	-181	-94	
				-92	-43	-114	-65	-131	-68	-152	-103	-169	-106	
280	315	-35	0	+66	+34	+88	+56	+108	+56	+130	+98	+150	+98	
				-101	-34	-123	-56	-143	-56	-165	-98	-185	-98	
				-92	-43	-114	-65	-131	-68	-156	-107	-173	-110	
315	355	-40	0	+73	+37	+98	+62	+119	+62	+144	+108	+165	+108	
				-113	-37	-138	-62	-159	-62	-184	-108	-205	-108	
				-102	-48	-127	-73	-146	-75	-173	-119	-192	-121	
355	400	-40	0	+73	+37	+98	+62	+119	+62	+150	+114	+171	+114	
				-113	-37	-138	-62	-159	-62	-190	-114	-211	-114	
				-102	-48	-127	-73	-146	-75	-179	-125	-198	-127	
400	450	-45	0	+80	+40	+108	+68	+131	+68	+166	+126	+189	+126	
				-125	-40	-153	-68	-176	-68	-211	-126	-234	-126	
				-113	-52	-141	-80	-161	-83	-199	-138	-219	-141	

Shaft tolerances and resultant fits (metric)

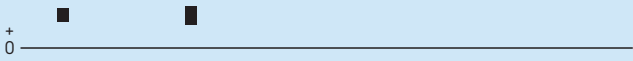


Shaft		Bearing		Deviations of shaft diameter, resultant fits									
Nominal diameter d		Bore diameter tolerance Δ _{dmp}		Tolerance classes									
				n6		p6		p7		r6		r7	
over	incl.	low	high	Deviations (shaft diameter)									
				Theoretical interference (-)									
				Probable interference (-)									
mm		μm		μm									
450	500	-45	0	+80	+40	+108	+68	+131	+68	+172	+132	+195	+132
				-125	-40	-153	-68	-176	-68	-217	-132	-240	-132
				-113	-52	-141	-80	-161	-83	-205	-144	-225	-147
500	560	-50	0	+88	+44	+122	+78	+148	+78	+194	+150	+220	+150
				-138	-44	-172	-78	-198	-78	-244	-150	-270	-150
				-125	-57	-159	-91	-182	-94	-231	-163	-254	-166
560	630	-50	0	+88	+44	+122	+78	+148	+78	+199	+155	+225	+155
				-138	-44	-172	-78	-198	-78	-249	-155	-275	-155
				-125	-57	-159	-91	-182	-94	-236	-168	-259	-171
630	710	-75	0	+100	+50	+138	+88	+168	+88	+225	+175	+255	+175
				-175	-50	-213	-88	-243	-88	-300	-175	-330	-175
				-158	-67	-196	-105	-221	-110	-283	-192	-308	-197
710	800	-75	0	+100	+50	+138	+88	+168	+88	+235	+185	+265	+185
				-175	-50	-213	-88	-243	-88	-310	-185	-340	-185
				-158	-67	-196	-105	-221	-110	-293	-202	-318	-207
800	900	-100	0	+112	+56	+156	+100	+190	+100	+266	+210	+300	+210
				-212	-56	-256	-100	-290	-100	-366	-210	-400	-210
				-192	-76	-236	-120	-263	-127	-346	-230	-373	-237
900	1000	-100	0	+112	+56	+156	+100	+190	+100	+276	+220	+310	+220
				-212	-56	-256	-100	-290	-100	-376	-220	-410	-220
				-192	-76	-236	-120	-263	-127	-356	-240	-383	-247
1000	1120	-125	0	+132	+66	+186	+120	+225	+120	+316	+250	+355	+250
				-257	-66	-311	-120	-350	-120	-441	-250	-480	-250
				-233	-90	-287	-144	-317	-153	-417	-274	-447	-283
1120	1250	-125	0	+132	+66	+186	+120	+225	+120	+326	+260	+365	+260
				-257	-66	-311	-120	-350	-120	-451	-260	-490	-260
				-233	-90	-287	-144	-317	-153	-427	-284	-457	-293
1250	1400	-160	0	+156	+78	+218	+140	+265	+140	+378	+300	+425	+300
				-316	-78	-378	-140	-425	-140	-538	-300	-585	-300
				-286	-108	-348	-170	-385	-180	-508	-330	-545	-340
1400	1600	-160	0	+156	+78	+218	+140	+265	+140	+408	+330	+455	+330
				-316	-78	-378	-140	-425	-140	-568	-330	-615	-330
				-286	-108	-348	-170	-385	-180	-538	-360	-575	-370
1600	1800	-200	0	+184	+92	+262	+170	+320	+170	+462	+370	+520	+370
				-384	-92	-462	-170	-520	-170	-662	-370	-720	-370
				-349	-127	-427	-205	-470	-220	-627	-405	-670	-420
1800	2000	-200	0	+184	+92	+262	+170	+320	+170	+492	+400	+550	+400
				-384	-92	-462	-170	-520	-170	-692	-400	-750	-400
				-349	-127	-427	-205	-470	-220	-657	-435	-700	-450

Shaft tolerances and resultant fits (metric)

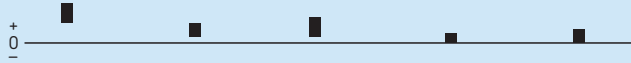
Shaft		Bearing		Deviations of shaft diameter, resultant fits			
Nominal diameter d		Bore diameter tolerance Δ_{dmp}		Tolerance classes			
				$s6_{min} \pm IT6/2$		$s7_{min} \pm IT7/2$	
over	incl.	low	high	Deviations (shaft diameter)			
				Theoretical interference (-)			
				Probable interference (-)			
mm		μm		μm			
200	225	-30	0	+144	+115	+153	+107
				-174	-115	-183	-107
				-166	-123	-173	-117
225	250	-30	0	+154	+125	+163	+117
				-184	-125	-193	-117
				-176	-133	-183	-127
250	280	-35	0	+174	+142	+184	+132
				-209	-142	-219	-132
				-200	-151	-207	-144
280	315	-35	0	+186	+154	+196	+144
				-221	-154	-231	-144
				-212	-163	-219	-156
315	355	-40	0	+208	+172	+218	+161
				-248	-172	-258	-161
				-237	-183	-245	-174
355	400	-40	0	+226	+190	+236	+179
				-266	-190	-276	-179
				-255	-201	-263	-192
400	450	-45	0	+252	+212	+263	+200
				-297	-212	-308	-200
				-285	-224	-293	-215
450	500	-45	0	+272	+232	+283	+220
				-317	-232	-328	-220
				-305	-244	-313	-235
500	560	-50	0	+302	+258	+315	+245
				-352	-258	-365	-245
				-339	-271	-349	-261
560	630	-50	0	+332	+288	+345	+275
				-382	-288	-395	-275
				-369	-301	-379	-291
630	710	-75	0	+365	+315	+380	+300
				-440	-315	-455	-300
				-423	-332	-433	-322
710	800	-75	0	+405	+355	+420	+340
				-480	-355	-495	-340
				-463	-372	-473	-362
800	900	-100	0	+458	+402	+475	+385
				-558	-402	-575	-385
				-538	-422	-548	-412
900	1000	-100	0	+498	+442	+515	+425
				-598	-442	-615	-425
				-578	-462	-588	-452

Shaft tolerances and resultant fits (metric)



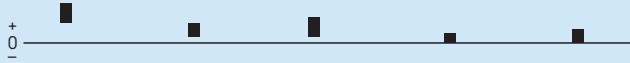
Shaft		Bearing		Deviations of shaft diameter, resultant fits			
Nominal diameter d		Bore diameter tolerance Δ_{dmp}		Tolerance classes			
over	incl.	low	high	$s6_{min} \pm IT6/2$ $s7_{min} \pm IT7/2$			
				Deviations (shaft diameter)			
				Theoretical interference (-)			
				Probable interference (-)			
mm		μm		μm			
1 000	1 120	-125	0	+553	+487	+572	+467
				-678	-487	-697	-467
				-654	-511	-664	-500
1 120	1 250	-125	0	+613	+547	+632	+527
				-738	-547	-757	-527
				-714	-571	-724	-560
1 250	1 400	-160	0	+679	+601	+702	+577
				-839	-601	-862	-577
				-809	-631	-822	-617
1 400	1 600	-160	0	+759	+681	+782	+657
				-919	-681	-942	-657
				-889	-711	-902	-697
1 600	1 800	-200	0	+866	+774	+895	+745
				-1 066	-774	-1 095	-745
				-1 031	-809	-1 045	-795
1 800	2 000	-200	0	+966	+874	+995	+845
				-1 166	-874	-1 195	-845
				-1 131	-909	-1 145	-895

Housing tolerances and resultant fits (metric)



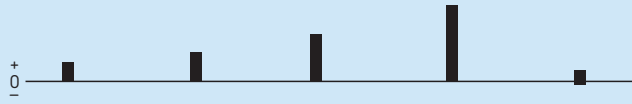
Housing Nominal bore diameter D		Bearing Outside diameter tolerance $\Delta_{D_{\text{Bmp}}}$		Deviations of housing bore diameter, resultant fits									
				Tolerance classes									
				F7	G6		G7		H5		H6		
				Deviations (housing bore diameter)									
				Theoretical clearance (+)									
				Probable clearance (+)									
over	incl.	high	low										
mm		μm		μm									
6	10	0	-8	+13	+28	+5	+14	+5	+20	0	+6	0	+9
				+13	+36	+5	+22	+5	+28	0	+14	0	+17
				+16	+33	+7	+20	+8	+25	+2	+12	+2	+15
10	18	0	-8	+16	+34	+6	+17	+6	+24	0	+8	0	+11
				+16	+42	+6	+25	+6	+32	0	+16	0	+19
				+19	+39	+8	+23	+9	+29	+2	+14	+2	+17
18	30	0	-9	+20	+41	+7	+20	+7	+28	0	+9	+0	+13
				+20	+50	+7	+29	+7	+37	0	+18	0	+22
				+23	+47	+10	+26	+10	+34	+2	+16	+3	+19
30	50	0	-11	+25	+50	+9	+25	+9	+34	0	+11	0	+16
				+25	+61	+9	+36	+9	+45	0	+22	0	+27
				+29	+57	+12	+33	+13	+41	+3	+19	+3	+24
50	80	0	-13	+30	+60	+10	+29	+10	+40	0	+13	0	+19
				+30	+73	+10	+42	+10	+53	0	+26	0	+32
				+35	+68	+14	+38	+15	+48	+3	+23	+4	+28
80	120	0	-15	+36	+71	+12	+34	+12	+47	0	+15	0	+22
				+36	+86	+12	+49	+12	+62	0	+30	0	+37
				+41	+81	+17	+44	+17	+57	+4	+26	+5	+32
120	150	0	-18	+43	+83	+14	+39	+14	+54	0	+18	0	+25
				+43	+101	+14	+57	+14	+72	0	+36	0	+43
				+50	+94	+20	+51	+21	+65	+5	+31	+6	+37
150	180	0	-25	+43	+83	+14	+39	+14	+54	0	+18	0	+25
				+43	+108	+14	+64	+14	+79	0	+43	0	+50
				+51	+100	+21	+57	+22	+71	+6	+37	+7	+43
180	250	0	-30	+50	+96	+15	+44	+15	+61	0	+20	0	+29
				+50	+126	+15	+74	+15	+91	0	+50	0	+59
				+60	+116	+23	+66	+25	+81	+6	+44	+8	+51
250	315	0	-35	+56	+108	+17	+49	+17	+69	0	+23	0	+32
				+56	+143	+17	+84	+17	+104	0	+58	0	+67
				+68	+131	+26	+75	+29	+92	+8	+50	+9	+58
315	400	0	-40	+62	+119	+18	+54	+18	+75	0	+25	0	+36
				+62	+159	+18	+94	+18	+115	0	+65	0	+76
				+75	+146	+29	+83	+31	+102	+8	+57	+11	+65
400	500	0	-45	+68	+131	+20	+60	+20	+83	0	+27	0	+40
				+68	+176	+20	+105	+20	+128	0	+72	0	+85
				+83	+161	+32	+93	+35	+113	+9	+63	+12	+73
500	630	0	-50	+76	+146	+22	+66	+22	+92	0	+28	0	+44
				+76	+196	+22	+116	+22	+142	0	+78	0	+94
				+92	+180	+35	+103	+38	+126	+10	+68	+13	+81
630	800	0	-75	+80	+160	+24	+74	+24	+104	0	+32	0	+50
				+80	+235	+24	+149	+24	+179	0	+107	0	+125
				+102	+213	+41	+132	+46	+157	+12	+95	+17	+108

Housing tolerances and resultant fits (metric)



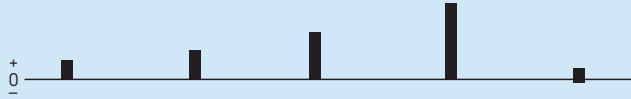
Housing Nominal bore diameter D		Bearing Outside diameter tolerance $\Delta_{D_{mp}}$		Deviations of housing bore diameter, resultant fits									
				Tolerance classes									
				F7	G6	G7		H5		H6			
				Deviations (housing bore diameter)									
				Theoretical clearance (+)									
				Probable clearance (+)									
over	incl.	high	low										
mm		μm		μm									
800	1000	0	-100	+86	+176	+26	+82	+26	+116	0	+36	0	+56
				+86	+276	+26	+182	+26	+216	0	+136	0	+156
				+113	+249	+46	+162	+53	+189	+14	+122	+20	+136
1000	1250	0	-125	+98	+203	+28	+94	+28	+133	0	+42	0	+66
				+98	+328	+28	+219	+28	+258	0	+167	0	+191
				+131	+295	+52	+195	+61	+225	+17	+150	+24	+167
1250	1600	0	-160	+110	+235	+30	+108	+30	+155	0	+50	0	+78
				+110	+395	+30	+268	+30	+315	0	+210	0	+238
				+150	+355	+60	+238	+70	+275	+21	+189	+30	+208
1600	2000	0	-200	+120	+270	+32	+124	+32	+182	0	+60	0	+92
				+120	+470	+32	+324	+32	+382	0	+260	0	+292
				+170	+420	+67	+289	+82	+332	+25	+235	+35	+257
2000	2500	0	-250	+130	+305	+34	+144	+34	+209	0	+70	0	+110
				+130	+555	+34	+394	+34	+459	0	+320	0	+360
				+189	+496	+77	+351	+93	+400	+30	+290	+43	+317

Housing tolerances and resultant fits (metric)



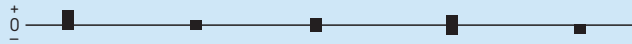
Housing		Bearing		Deviations of housing bore diameter, resultant fits																													
Nominal bore diameter D		Outside diameter tolerance Δ _{Dmp}		Tolerance classes																													
				H7			H8			H9			H10			J6																	
				Deviations (housing bore diameter)																													
				Theoretical interference (-)/clearance (+)																													
				Probable interference (-)/clearance (+)																													
over	incl.	high	low																														
mm		µm		µm																													
6	10	0	-8	0	+15	0	+22	0	+36	0	+58	-4	+5	0	+23	0	+30	0	+44	0	+66	-4	+13	+3	+20	+3	+27	+3	+41	+3	+63	-2	+11
				0	+18	0	+27	0	+43	0	+70	-5	+6	0	+26	0	+35	0	+51	0	+78	-5	+14	+3	+23	+3	+32	+3	+48	+3	+75	-3	+12
				0	+21	0	+33	0	+52	0	+84	-5	+8	0	+30	0	+42	0	+61	0	+93	-5	+17	+3	+27	+3	+39	+4	+57	+4	+89	-2	+14
30	50	0	-11	0	+25	0	+39	0	+62	0	+100	-6	+10	0	+36	0	+50	0	+73	0	+111	-6	+21	+4	+32	+4	+46	+5	+68	+5	+106	-3	+18
				0	+30	0	+46	0	+74	0	+120	-6	+13	0	+43	0	+59	0	+87	0	+133	-6	+26	+5	+38	+5	+54	+5	+82	+6	+127	-2	+22
				0	+35	0	+54	0	+87	0	+140	-6	+16	0	+50	0	+69	0	+102	0	+155	-6	+31	+5	+45	+6	+63	+6	+96	+7	+148	-1	+26
120	150	0	-18	0	+40	0	+63	0	+100	0	+160	-7	+18	0	+58	0	+81	0	+118	0	+178	-7	+36	+7	+51	+7	+74	+8	+110	+8	+170	-1	+30
				0	+40	0	+63	0	+100	0	+160	-7	+18	0	+65	0	+88	0	+125	0	+185	-7	+43	+8	+57	+10	+78	+10	+115	+11	+174	0	+36
				0	+46	0	+72	0	+115	0	+185	-7	+22	0	+76	0	+102	0	+145	0	+215	-7	+52	+10	+66	+12	+90	+13	+132	+13	+202	+1	+44
250	315	0	-35	0	+52	0	+81	0	+130	0	+210	-7	+25	0	+87	0	+116	0	+165	0	+245	-7	+60	+12	+75	+13	+103	+15	+150	+16	+229	+2	+51
				0	+57	0	+89	0	+140	0	+230	-7	+29	0	+97	0	+129	0	+180	0	+270	-7	+69	+13	+84	+15	+114	+17	+163	+18	+252	+4	+58
				0	+63	0	+97	0	+155	0	+250	-7	+33	0	+108	0	+142	0	+200	0	+295	-7	+78	+15	+93	+17	+125	+19	+181	+20	+275	+5	+66
500	630	0	-50	0	+70	0	+110	0	+175	0	+280	-	-	0	+120	0	+160	0	+225	0	+330	-	-	+16	+104	+19	+141	+21	+204	+22	+308	-	-
				0	+80	0	+125	0	+200	0	+320	-	-	0	+155	0	+200	0	+275	0	+395	-	-	+22	+133	+27	+173	+30	+245	+33	+362	-	-
				0	+70	0	+110	0	+175	0	+280	-	-	0	+120	0	+160	0	+225	0	+330	-	-	+16	+104	+19	+141	+21	+204	+22	+308	-	-
630	800	0	-75	0	+80	0	+125	0	+200	0	+320	-	-	0	+155	0	+200	0	+275	0	+395	-	-	+22	+133	+27	+173	+30	+245	+33	+362	-	-

Housing tolerances and resultant fits (metric)



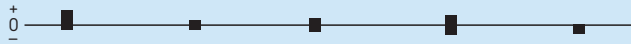
Housing Nominal bore diameter D		Bearing Outside diameter tolerance $\Delta_{D_{mp}}$		Deviations of housing bore diameter, resultant fits																													
				Tolerance classes		H7		H8		H9		H10		J6																			
				Deviations (housing bore diameter)																													
				Theoretical interference (-)/clearance (+)																													
				Probable interference (-)/clearance (+)																													
over	incl.	high	low																														
mm		μm		μm																													
800	1 000	0	-100	0	+90	0	+140	0	+230	0	+360	-	-	0	+190	0	+240	0	+330	0	+460	-	-	+27	+163	+33	+207	+39	+291	+43	+417	-	-
				0	+105	0	+165	0	+260	0	+420	-	-	0	+230	0	+290	0	+385	0	+545	-	-	+33	+197	+41	+249	+48	+337	+53	+492	-	-
				0	+125	0	+195	0	+310	0	+500	-	-	0	+285	0	+355	0	+470	0	+660	-	-	+40	+245	+51	+304	+60	+410	+67	+593	-	-
1 000	1 250	0	-125	0	+150	0	+230	0	+370	0	+600	-	-	0	+350	0	+430	0	+570	0	+800	-	-	+50	+300	+62	+368	+74	+496	+83	+717	-	-
				0	+175	0	+280	0	+440	0	+700	-	-	0	+425	0	+530	0	+690	0	+950	-	-	+59	+366	+77	+453	+91	+599	+103	+847	-	-
				0	+125	0	+195	0	+310	0	+500	-	-	0	+285	0	+355	0	+470	0	+660	-	-	+40	+245	+51	+304	+60	+410	+67	+593	-	-
1 250	1 600	0	-160	0	+150	0	+230	0	+370	0	+600	-	-	0	+350	0	+430	0	+570	0	+800	-	-	+50	+300	+62	+368	+74	+496	+83	+717	-	-
				0	+175	0	+280	0	+440	0	+700	-	-	0	+425	0	+530	0	+690	0	+950	-	-	+59	+366	+77	+453	+91	+599	+103	+847	-	-
				0	+125	0	+195	0	+310	0	+500	-	-	0	+285	0	+355	0	+470	0	+660	-	-	+40	+245	+51	+304	+60	+410	+67	+593	-	-
1 600	2 000	0	-200	0	+150	0	+230	0	+370	0	+600	-	-	0	+350	0	+430	0	+570	0	+800	-	-	+50	+300	+62	+368	+74	+496	+83	+717	-	-
				0	+175	0	+280	0	+440	0	+700	-	-	0	+425	0	+530	0	+690	0	+950	-	-	+59	+366	+77	+453	+91	+599	+103	+847	-	-
				0	+125	0	+195	0	+310	0	+500	-	-	0	+285	0	+355	0	+470	0	+660	-	-	+40	+245	+51	+304	+60	+410	+67	+593	-	-
2 000	2 500	0	-250	0	+150	0	+230	0	+370	0	+600	-	-	0	+350	0	+430	0	+570	0	+800	-	-	+50	+300	+62	+368	+74	+496	+83	+717	-	-
				0	+175	0	+280	0	+440	0	+700	-	-	0	+425	0	+530	0	+690	0	+950	-	-	+59	+366	+77	+453	+91	+599	+103	+847	-	-
				0	+125	0	+195	0	+310	0	+500	-	-	0	+285	0	+355	0	+470	0	+660	-	-	+40	+245	+51	+304	+60	+410	+67	+593	-	-

Housing tolerances and resultant fits (metric)



Housing Nominal bore diameter D		Bearing Outside diameter $\Delta_{D_{mp}}$		Deviations of housing bore diameter, resultant fits																																	
				Tolerance classes																																	
				J7	JS5	JS6	JS7	K5																													
				Deviations (housing bore diameter)																																	
				Theoretical interference (-)/clearance (+)																																	
				Probable interference (-)/clearance (+)																																	
over	incl.	high	low																																		
mm		μm		μm																																	
6	10	0	-8	-7	+8	-3	+3	-4,5	+4,5	-7,5	+7,5	-5	+1	-7	+16	-3	+11	-4,5	+12,5	-7,5	+15,5	-5	+9	-4	+13	-1	+9	-3	+11	-5	+13	-3	+7				
				10	18	0	-8	-8	+10	-4	+4	-5,5	+5,5	-9	+9	-6	+2	-8	+18	-4	+12	-5,5	+13,5	-9	+17	-6	+10	-5	+15	-2	+10	-3	+11	-6	+14	-4	+8
								18	30	0	-9	-9	+12	-4,5	+4,5	-6,5	+6,5	-10,5	+10,5	-8	+1	-9	+21	-4,5	+13,5	-6,5	+15,5	-10,5	+19,5	-8	+10	-6	+18	-2	+11	-4	+13
30	50	0	-11	-11	+14	-5,5	+5,5					-8	+8	-12,5	+12,5	-9	+2	-11	+25	-5,5	+16,5	-8	+19	-12,5	+23,5	-9	+13	-7	+21	-3	+14	-5	+16	-9	+20	-6	+10
				50	80	0	-13					-12	+18	-6,5	+6,5	-9,5	+9,5	-15	+15	-10	+3	-12	+31	-6,5	+19,5	-9,5	+22,5	-15	+28	-10	+16	-7	+26	-3	+16	-6	+19
								80	120	0	-15	-13	+22	-7,5	+7,5	-11	+11	-17,5	+17,5	-13	+2	-13	+37	-7,5	+22,5	-11	+26	-17,5	+32,5	-13	+17	-8	+32	-4	+19	-6	+21
120	150	0	-18									-14	+26	-9	+9	-12,5	+12,5	-20	+20	-15	+3	-14	+44	-9	+27	-12,5	+30,5	-20	+38	-15	+21	-7	+37	-4	+22	-7	+25
				150	180	0	-25					-14	+26	-9	+9	-12,5	+12,5	-20	+20	-15	+3	-14	+51	-9	+34	-12,5	+37,5	-20	+45	-15	+28	-6	+43	-3	+28	-6	+31
								180	250	0	-30	-16	+30	-10	+10	-14,5	+14,5	-23	+23	-18	+2	-16	+60	-10	+40	-14,5	+44,5	-23	+53	-18	+32	-6	+50	-4	+34	-6	+36
250	315	0	-35									-16	+36	-11,5	+11,5	-16	+16	-26	+26	-20	+3	-16	+71	-11,5	+46,5	-16	+51	-26	+61	-20	+38	-4	+59	-4	+39	-7	+42
				315	400	0	-40					-18	+39	-12,5	+12,5	-18	+18	-28,5	+28,5	-22	+3	-18	+79	-12,5	+52,5	-18	+58	-28,5	+68,5	-22	+43	-5	+66	-4	+44	-7	+47
								400	500	0	-45	-20	+43	-13,5	+13,5	-20	+20	-31,5	+31,5	-25	+2	-20	+88	-13,5	+58,5	-20	+65	-31,5	+76,5	-25	+47	-5	+73	-4	+49	-8	+53
500	630	0	-50									-	-	-14	+14	-22	+22	-35	+35	-	-	-	-	-14	+64	-22	+72	-35	+85	-	-	-	-	-4	+54	-9	+59
				630	800	0	-75					-	-	-16	+16	-25	+25	-40	+40	-	-	-	-	-16	+91	-25	+100	-40	+115	-	-	-	-	-4	+79	-8	+83

Housing tolerances and resultant fits (metric)



Housing Nominal bore diameter D		Bearing Outside diameter tolerance $\Delta_{D_{mp}}$		Deviations of housing bore diameter, resultant fits									
				Tolerance classes									
				J7	JS5	JS6	JS7	K5					
				Deviations (housing bore diameter)									
				Theoretical interference (-)/clearance (+)									
				Probable interference (-)/clearance (+)									
over	incl.	high	low	μm									
mm		μm		μm									
800	1 000	0	-100	-	-	-18	+18	-28	+28	-45	+45	-	-
				-	-	-18	+118	-28	+128	-45	+145	-	-
				-	-	-4	+104	-8	+108	-18	+118	-	-
1 000	1 250	0	-125	-	-	-21	+21	-33	+33	-52	+52	-	-
				-	-	-21	+146	-33	+158	-52	+177	-	-
				-	-	-4	+129	-9	+134	-20	+145	-	-
1 250	1 600	0	-160	-	-	-25	+25	-39	+39	-62	+62	-	-
				-	-	-25	+185	-39	+199	-62	+222	-	-
				-	-	-4	+164	-9	+169	-22	+182	-	-
1 600	2 000	0	-200	-	-	-30	+30	-46	+46	-75	+75	-	-
				-	-	-30	+230	-46	+246	-75	+275	-	-
				-	-	-5	+205	-11	+211	-25	+225	-	-
2 000	2 500	0	-250	-	-	-35	+35	-55	+55	-87	+87	-	-
				-	-	-35	+285	-55	+305	-87	+337	-	-
				-	-	-5	+255	-12	+262	-28	+278	-	-

Housing tolerances and resultant fits (metric)




Housing Nominal bore diameter D		Bearing Outside diameter tolerance $\Delta_{D_{mp}}$		Deviations of housing bore diameter, resultant fits																																	
				Tolerance classes																																	
				K6		K7		M5		M6		M7																									
				Deviations (housing bore diameter)																																	
				Theoretical interference (-)/clearance (+)																																	
				Probable interference (-)/clearance (+)																																	
over	incl.	high	low																																		
mm		μm		μm																																	
6	10	0	-8	-7	+2	-10	+5	-10	-4	-12	-3	-15	0	-7	+10	-10	+13	-10	+4	-12	+5	-15	+8	-5	+8	-7	+10	-8	+2	-10	+3	-12	+5				
				10	18	0	-8	-9	+2	-12	+6	-12	-4	-15	-4	-18	0	-9	+10	-12	+14	-12	+4	-15	+4	-18	+8	-7	+8	-9	+11	-10	+2	-13	+2	-15	+5
								18	30	0	-9	-11	+2	-15	+6	-14	-4	-17	-4	-21	0	-11	+11	-15	+15	-14	+4	-17	+5	-21	+9	-8	+8	-12	+12	-12	+2
30	50	0	-11									-13	+3	-18	+7	-16	-5	-20	-4	-25	0	-13	+14	-18	+18	-16	+6	-20	+7	-25	+11	-10	+11	-14	+14	-13	+3
				50	80	0	-13					-15	+4	-21	+9	-19	-6	-24	-5	-30	0	-15	+17	-21	+22	-19	+7	-24	+8	-30	+13	-11	+13	-16	+17	-16	+4
								80	120	0	-15	-18	+4	-25	+10	-23	-8	-28	-6	-35	0	-18	+19	-25	+25	-23	+7	-28	+9	-35	+15	-13	+14	-20	+20	-19	+3
120	150	0	-18									-21	+4	-28	+12	-27	-9	-33	-8	-40	0	-21	+22	-28	+30	-27	+9	-33	+10	-40	+18	-15	+16	-21	+23	-22	+4
				150	180	0	-25					-21	+4	-28	+12	-27	-9	-33	-8	-40	0	-21	+29	-28	+37	-27	+16	-33	+17	-40	+25	-14	+22	-20	+29	-21	+10
								180	250	0	-30	-24	+5	-33	+13	-31	-11	-37	-8	-46	0	-24	+35	-33	+43	-31	+19	-37	+22	-46	+30	-16	+27	-23	+33	-25	+13
250	315	0	-35									-27	+5	-36	+16	-36	-13	-41	-9	-52	0	-27	+40	-36	+51	-36	+22	-41	+26	-52	+35	-18	+31	-24	+39	-28	+14
				315	400	0	-40					-29	+7	-40	+17	-39	-14	-46	-10	-57	0	-29	+47	-40	+57	-39	+26	-46	+30	-57	+40	-18	+36	-27	+44	-31	+18
								400	500	0	-45	-32	+8	-45	+18	-43	-16	-50	-10	-63	0	-32	+53	-45	+63	-43	+29	-50	+35	-63	+45	-20	+41	-30	+48	-34	+20
500	630	0	-50									-44	0	-70	0	-	-	-70	-26	-96	-26	-44	+50	-70	+50	-	-	-70	+24	-96	+24	-31	+37	-54	+34	-	-
				630	800	0	-75					-50	0	-80	0	-	-	-80	-30	-110	-30	-50	+75	-80	+75	-	-	-80	+45	-110	+45	-33	+58	-58	+53	-	-

Housing tolerances and resultant fits (metric)



Housing Nominal bore diameter D		Bearing Outside diameter tolerance $\Delta_{D_{mp}}$		Deviations of housing bore diameter, resultant fits																													
				Tolerance classes		K6		K7		M5		M6		M7																			
				Deviations (housing bore diameter)																													
				Theoretical interference (-)/clearance (+)																													
				Probable interference (-)/clearance (+)																													
over	incl.	high	low	μm																													
mm		μm		μm																													
800	1 000	0	-100	-56	0	-90	0	-	-	-90	-34	-124	-34	-56	+100	-90	+100	-	-	-90	+66	-124	+66	-36	+80	-63	+73	-	-	-70	+46	-97	+39
				-66	0	-105	0	-	-	-106	-40	-145	-40	-66	+125	-105	+125	-	-	-106	+85	-145	+85	-42	+101	-72	+92	-	-	-82	+61	-112	+52
				-78	0	-125	0	-	-	-126	-48	-173	-48	-78	+160	-125	+160	-	-	-126	+112	-173	+112	-48	+130	-85	+120	-	-	-96	+82	-133	+72
1 600	2 000	0	-200	-92	0	-150	0	-	-	-158	-58	-208	-58	-92	+200	-150	+200	-	-	-150	+142	-208	+142	-57	+165	-100	+150	-	-	-115	+107	-158	+92
				-110	0	-175	0	-	-	-178	-68	-243	-68	-110	+250	-175	+250	-	-	-178	+182	-243	+182	-67	+207	-116	+191	-	-	-135	+139	-184	+123
				-110	0	-175	0	-	-	-178	-68	-243	-68	-110	+250	-175	+250	-	-	-178	+182	-243	+182	-67	+207	-116	+191	-	-	-135	+139	-184	+123

Housing tolerances and resultant fits (metric)



Housing Nominal bore diameter D		Bearing Outside diameter Δ_{Dmp}		Deviations of housing bore diameter, resultant fits							
				Tolerance classes							
				N6		N7		P6		P7	
				Deviations (housing bore diameter)							
				Theoretical interference (-)/clearance (+)							
				Probable interference (-)/clearance (+)							
over	incl.	high	low								
mm		μm		μm							
6	10	0	-8	-16	-7	-19	-4	-21	-12	-24	-9
				-16	+1	-19	+4	-21	-4	-24	-1
				-14	-1	-16	+1	-19	-6	-21	-4
10	18	0	-8	-20	-9	-23	-5	-26	-15	-29	-11
				-20	-1	-23	+3	-26	-7	-29	-3
				-18	-3	-20	0	-24	-9	-26	-6
18	30	0	-9	-24	-11	-28	-7	-31	-18	-35	-14
				-24	-2	-28	+2	-31	-9	-35	-5
				-21	-5	-25	-1	-28	-12	-32	-8
30	50	0	-11	-28	-12	-33	-8	-37	-21	-42	-17
				-28	-1	-33	+3	-37	-10	-42	-6
				-25	-4	-29	-1	-34	-13	-38	-10
50	80	0	-13	-33	-14	-39	-9	-45	-26	-51	-21
				-33	-1	-39	+4	-45	-13	-51	-8
				-29	-5	-34	-1	-41	-17	-46	-13
80	120	0	-15	-38	-16	-45	-10	-52	-30	-59	-24
				-38	-1	-45	+5	-52	-15	-59	-9
				-33	-6	-40	0	-47	-20	-54	-14
120	150	0	-18	-45	-20	-52	-12	-61	-36	-68	-28
				-45	-2	-52	+6	-61	-18	-68	-10
				-39	-8	-45	-1	-55	-24	-61	-17
150	180	0	-25	-45	-20	-52	-12	-61	-36	-68	-28
				-45	+5	-52	+13	-61	-11	-68	-3
				-38	-2	-44	+5	-54	-18	-60	-11
180	250	0	-30	-51	-22	-60	-14	-70	-41	-79	-33
				-51	+8	-60	+16	-70	-11	-79	-3
				-43	0	-50	+6	-62	-19	-69	-13
250	315	0	-35	-57	-25	-66	-14	-79	-47	-88	-36
				-57	+10	-66	+21	-79	-12	-88	-1
				-48	+1	-54	+9	-70	-21	-76	-13
315	400	0	-40	-62	-26	-73	-16	-87	-51	-98	-41
				-62	+14	-73	+24	-87	-11	-98	-1
				-51	+3	-60	+11	-76	-22	-85	-14
400	500	0	-45	-67	-27	-80	-17	-95	-55	-108	-45
				-67	+18	-80	+28	-95	-10	-108	0
				-55	+6	-65	+13	-83	-22	-93	-15
500	630	0	-50	-88	-44	-114	-44	-122	-78	-148	-78
				-88	+6	-114	+6	-122	-28	-148	-28
				-75	-7	-98	-10	-109	-41	-132	-44
630	800	0	-75	-100	-50	-130	-50	-138	-88	-168	-88
				-100	+25	-130	+25	-138	-13	-168	-13
				-83	+8	-108	+3	-121	-30	-146	-35

Housing tolerances and resultant fits (metric)

Housing Nominal bore diameter D		Bearing Outside diameter tolerance $\Delta_{D_{mp}}$		Deviations of housing bore diameter, resultant fits Tolerance classes							
				N6		N7		P6		P7	
				Deviations (housing bore diameter)							
				Theoretical interference (-)/clearance (+)							
				Probable interference (-)/clearance (+)							
over	incl.	high	low	mm							
				μm							
800	1 000	0	-100	-112	-56	-146	-56	-156	-100	-190	-100
				-112	+44	-146	+44	-156	0	-190	0
				-92	+24	-119	+17	-136	-20	-163	-27
1 000	1 250	0	-125	-132	-66	-171	-66	-186	-120	-225	-120
				-132	+59	-171	+59	-186	+5	-225	+5
				-108	+35	-138	+26	-162	-19	-192	-28
1 250	1 600	0	-160	-156	-78	-203	-78	-218	-140	-265	-140
				-156	+82	-203	+82	-218	+20	-265	+20
				-126	+52	-163	+42	-188	-10	-225	-20
1 600	2 000	0	-200	-184	-92	-242	-92	-262	-170	-320	-170
				-184	+108	-242	+108	-262	+30	-320	+30
				-149	+73	-192	+58	-227	-5	-270	-20
2 000	2 500	0	-250	-220	-110	-285	-110	-305	-195	-370	-195
				-220	+140	-285	+140	-305	+55	-370	+55
				-177	+97	-226	+81	-262	+12	-311	-4

Shaft tolerances and resultant fits (inch)

Bearing bore diameter d		Resultant fits											
		Tolerance classes f5			f6			g5			g6		
		Shaft diameter		Fit ¹⁾	Shaft diameter		Fit ¹⁾	Shaft diameter		Fit ¹⁾	Shaft diameter		Fit ¹⁾
		max	min		max	min		max	min		max	min	
mm	in.	in.			-	in.	-	in.	-	in.	-	in.	-
4	0.1575	0.1572	0.1571	0.1569	1L	0.1571	0.1568	1L	0.1573	0.1571	4L	0.1573	0.1570
5	0.1969	0.1966	0.1965	0.1963	6L	0.1965	0.1962	7L	0.1967	0.1965	1T	0.1967	0.1964
6	0.2362	0.2359	0.2358	0.2356		0.2358	0.2355		0.2360	0.2358		0.2360	0.2357
7	0.2756	0.2753	0.2751	0.2749		0.2751	0.2747		0.2754	0.2752		0.2754	0.2750
8	0.3150	0.3147	0.3145	0.3143	2L	0.3145	0.3141	2L	0.3148	0.3146	4L	0.3148	0.3144
9	0.3543	0.3540	0.3538	0.3536	7L	0.3538	0.3534	9L	0.3541	0.3539	1T	0.3541	0.3537
10	0.3937	0.3934	0.3932	0.3930		0.3932	0.3928		0.3935	0.3933		0.3935	0.3931
12	0.4724	0.4721	0.4718	0.4714	3L	0.4718	0.4713	3L	0.4722	0.4720	4L	0.4722	0.4717
15	0.5906	0.5903	0.5900	0.5896	10L	0.5900	0.5895	11L	0.5904	0.5902	1T	0.5904	0.5899
17	0.6693	0.6690	0.6687	0.6683		0.6687	0.6682		0.6691	0.6689		0.6691	0.6686
20	0.7874	0.7870	0.7866	0.7863	4L	0.7866	0.7861	4L	0.7871	0.7868	6L	0.7871	0.7866
25	0.9843	0.9839	0.9835	0.9832	11L	0.9835	0.9830	13L	0.9840	0.9837	1T	0.9840	0.9835
30	1.1811	1.1807	1.1803	1.1800		1.1803	1.1798		1.1808	1.1805		1.1808	1.1803
35	1.3780	1.3775	1.3770	1.3766		1.3770	1.3763		1.3776	1.3772		1.3776	1.3770
40	1.5748	1.5743	1.5738	1.5734	5L	1.5738	1.5731	5L	1.5744	1.5740	8L	1.5744	1.5738
45	1.7717	1.7712	1.7707	1.7703	14L	1.7707	1.7700	17L	1.7713	1.7709	1T	1.7713	1.7707
50	1.9685	1.9680	1.9675	1.9671		1.9675	1.9668		1.9681	1.9677		1.9681	1.9675
55	2.1654	2.1648	2.1642	2.1637		2.1642	2.1634		2.1650	2.1645		2.1650	2.1643
60	2.3622	2.3616	2.3610	2.3605		2.3610	2.3602		2.3618	2.3613		2.3618	2.3611
65	2.5591	2.5585	2.5579	2.5574	6L	2.5579	2.5571	6L	2.5587	2.5582	9L	2.5587	2.5580
70	2.7559	2.7553	2.7547	2.7542	17L	2.7547	2.7539	20L	2.7555	2.7550	2T	2.7555	2.7548
75	2.9528	2.9522	2.9516	2.9511		2.9516	2.9508		2.9524	2.9519		2.9524	2.9517
80	3.1496	3.1490	3.1484	3.1479		3.1484	3.1476		3.1492	3.1487		3.1492	3.1485
85	3.3465	3.3457	3.3451	3.3445		3.3450	3.3442		3.3460	3.3454		3.3460	3.3452
90	3.5433	3.5425	3.5419	3.5413		3.5418	3.5410		3.5428	3.5422		3.5428	3.5420
95	3.7402	3.7394	3.7388	3.7382		3.7387	3.7379		3.7397	3.7391		3.7397	3.7389
100	3.9370	3.9362	3.9356	3.9350	6L	3.9355	3.9347	7L	3.9365	3.9359	11L	3.9365	3.9357
105	4.1339	4.1331	4.1325	4.1319	20L	4.1324	4.1316	23L	4.1334	4.1328	3T	4.1334	4.1326
110	4.3307	4.3299	4.3293	4.3287		4.3292	4.3284		4.3302	4.3296		4.3302	4.3294
120	4.7244	4.7236	4.7230	4.7224		4.7229	4.7221		4.7239	4.7233		4.7239	4.7231
130	5.1181	5.1171	5.1164	5.1157		5.1164	5.1154		5.1176	5.1169		5.1175	5.1166
140	5.5118	5.5108	5.5101	5.5094		5.5101	5.5091		5.5113	5.5106		5.5112	5.5103
150	5.9055	5.9045	5.9038	5.9031	7L	5.9038	5.9028	7L	5.9050	5.9043	12L	5.9049	5.9040
160	6.2992	6.2982	6.2975	6.2968	24L	6.2975	6.2965	27L	6.2987	6.2980	5T	6.2986	6.2977
170	6.6929	6.6919	6.6912	6.6905		6.6912	6.6902		6.6924	6.6917		6.6923	6.6914
180	7.0866	7.0856	7.0849	7.0842		7.0849	7.0839		7.0861	7.0854		7.0860	7.0851
190	7.4803	7.4791	7.4783	7.4776		7.4783	7.4772		7.4797	7.4789		7.4797	7.4786
200	7.8740	7.8728	7.8720	7.8713	8L	7.8720	7.8709	8L	7.8734	7.8726	14L	7.8734	7.8723
220	8.6614	8.6602	8.6594	8.6587	27L	8.6594	8.6583	31L	8.6608	8.6600	6T	8.6608	8.6597
240	9.4488	9.4476	9.4468	9.4461		9.4468	9.4457		9.4482	9.4474		9.4482	9.4471

¹⁾ Resultant fit in 0.0001 in. L indicates a clearance (loose) fit, T indicates an interference (tight) fit.

Shaft tolerances and resultant fits (inch)

Bearing bore diameter d	Resultant fits															
	max		min		Tolerance classes f5 Shaft diameter		f6 Shaft diameter		g5 Shaft diameter		g6 Shaft diameter					
	max	min	max	min	Fit ¹⁾	max	min	Fit ¹⁾	max	min	Fit ¹⁾	max	min	Fit ¹⁾		
mm	in.	in.		–	in.	–		in.	–		in.	–				
260	10.2362	10.2348	10.2340	10.2331	8 L 31 L	10.2340	10.2328	8 L 34 L	10.2356	10.2346	16 L 8 T	10.2355	10.2343	19 L 7 T		
280	11.0236	11.0222	11.0214	11.0205		11.0214	11.0202		11.0230	11.0220		11.0229	11.0217		11.0229	11.0217
300	11.8110	11.8096	11.8088	11.8079		11.8088	11.8076		11.8104	11.8094		11.8103	11.8091			
320	12.5984	12.5968	12.5960	12.5950	8 L 34 L	12.5960	12.5946	8 L 38 L	12.5977	12.5967	17 L 9 T	12.5977	12.5963	21 L 9 T		
340	13.3858	13.3842	13.3834	13.3824		13.3834	13.3820		13.3851	13.3841		13.3851	13.3837			
360	14.1732	14.1716	14.1708	14.1698		14.1708	14.1694		14.1725	14.1715		14.1725	14.1711			
380	14.9606	14.9590	14.9582	14.9572		14.9582	14.9568		14.9599	14.9589		14.9599	14.9585			
400	15.7480	15.7464	15.7456	15.7446		15.7456	15.7442		15.7473	15.7463		15.7473	15.7459			
420	16.5354	16.5336	16.5328	16.5317	8 L 37 L	16.5328	16.5312	8 L 42 L	16.5346	16.5336	18 L 10 T	16.5346	16.5330	24 L 10 T		
440	17.3228	17.3210	17.3202	17.3191		17.3202	17.3186		17.3220	17.3210		17.3220	17.3204			
460	18.1102	18.1084	18.1076	18.1065		18.1076	18.1060		18.1094	18.1084		18.1094	18.1078			
480	18.8976	18.8958	18.8950	18.8939		18.8950	18.8934		18.8968	18.8958		18.8968	18.8952			
500	19.6850	19.6832	19.6824	19.6813		19.6824	19.6808		19.6842	19.6832		19.6842	19.6826			
530	20.8661	20.8641	20.8632	20.8621		9 L 40 L	20.8632		20.8614	9 L 47 L		20.8653	20.8642		19 L 12 T	20.8652
560	22.0472	22.0452	22.0443	22.0432	22.0443		22.0425	22.0464	22.0453		22.0463	22.0446				
600	23.6220	23.6200	23.6191	23.6180	23.6191		23.6173	23.6212	23.6201		23.6211	23.6194				
630	24.8031	24.8011	24.8002	24.7991	24.8002		24.7984	24.8023	24.8012		24.8022	24.8005				
670	26.3780	26.3750	26.3748	26.3735	2 L 45 L	26.3748	26.3728	2 L 52 L	26.3770	26.3758	22 L 20 T	26.3771	26.3751	29 L 21 T		
710	27.9528	27.9498	27.9496	27.9483		27.9496	27.9476		27.9518	27.9506		27.9519	27.9499			
750	29.5276	29.5246	29.5244	29.5231		29.5244	29.5224		29.5266	29.5254		29.5267	29.5247			
800	31.4961	31.4931	31.4929	31.4916		31.4929	31.4909		31.4951	31.4939		31.4952	31.4932			
850	33.4646	33.4607	33.4612	33.4598	4 L 5 T	33.4612	33.4590	5 L 5 T	33.4635	33.4621	25 L 28 T	33.4636	33.4614	32 L 29 T		
900	35.4331	35.4292	35.4297	35.4283		35.4297	35.4275		35.4320	35.4306		35.4321	35.4299			
950	37.4016	37.3977	37.3982	37.3968		37.3982	37.3960		37.4005	37.3991		37.4006	37.3984			
1000	39.3701	39.3662	39.3667	39.3653		39.3667	39.3645		39.3690	39.3676		39.3691	39.3669			
1060	41.7323	41.7274	41.7284	41.7268	5 L 10 T	41.7284	41.7258	6 L 10 T	41.7312	41.7295	28 L 38 T	41.7312	41.7286	37 L 38 T		
1120	44.0945	44.0896	44.0906	44.0890		44.0906	44.0880		44.0934	44.0917		44.0934	44.0908			
1180	46.4567	46.4518	46.4528	46.4512		46.4528	46.4502		46.4556	46.4539		46.4556	46.4530			
1250	49.2126	49.2077	49.2087	49.2071		49.2087	49.2061		49.2115	49.2098		49.2115	49.2089			

¹⁾ Resultant fit in 0.0001 in. L indicates a clearance (loose) fit, T indicates an interference (tight) fit.

Shaft tolerances and resultant fits (inch)

Bearing bore diameter d	Resultant fits Tolerance classes		h5		Fit ¹⁾	h6		Fit ¹⁾	h8		Fit ¹⁾	h9		Fit ¹⁾
			Shaft diameter			Shaft diameter			Shaft diameter			Shaft diameter		
	max	min	max	min	max	min	max	min	max	min	max	min		
mm	in.	in.		-	in.	-	in.	-	in.	-	in.	-		
4	0.1575	0.1572	0.1575	0.1573	2 L	0.1575	0.1572	3 L	0.1575	0.1568	7 L	0.1575	0.1563	
5	0.1969	0.1966	0.1969	0.1967	3 T	0.1969	0.1966	3 T	0.1969	0.1962	3 T	0.1969	0.1957	
6	0.2362	0.2359	0.2362	0.2360		0.2362	0.2359		0.2362	0.2355		0.2362	0.2350	
7	0.2756	0.2753	0.2756	0.2754		0.2756	0.2752		0.2756	0.2747		0.2756	0.2742	
8	0.3150	0.3147	0.3150	0.3148	2 L	0.3150	0.3146	4 L	0.3150	0.3141	9 L	0.3150	0.3136	
9	0.3543	0.3540	0.3543	0.3541	3 T	0.3543	0.3539	3 T	0.3543	0.3534	3 T	0.3543	0.3529	
10	0.3937	0.3934	0.3937	0.3935		0.3937	0.3933		0.3937	0.3928		0.3937	0.3923	
12	0.4724	0.4721	0.4724	0.4721		0.4724	0.4720		0.4724	0.4713		0.4724	0.4707	
15	0.5906	0.5903	0.5906	0.5903	3 L	0.5906	0.5902	4 L	0.5906	0.5895	11 L	0.5906	0.5889	
17	0.6693	0.6690	0.6693	0.6690	3 T	0.6693	0.6689	3 T	0.6693	0.6682	3 T	0.6693	0.6676	
20	0.7874	0.7870	0.7874	0.7870	4 L	0.7874	0.7869	5 L	0.7874	0.7861	13 L	0.7874	0.7854	
25	0.9843	0.9839	0.9843	0.9839	4 T	0.9843	0.9838	4 T	0.9843	0.9830	4 T	0.9843	0.9823	
30	1.1811	1.1807	1.1811	1.1807		1.1811	1.1806		1.1811	1.1798		1.1811	1.1791	
35	1.3780	1.3775	1.3780	1.3776		1.3780	1.3774		1.3780	1.3765		1.3780	1.3756	
40	1.5748	1.5743	1.5748	1.5744	4 L	1.5748	1.5742	6 L	1.5748	1.5733	15 L	1.5748	1.5724	
45	1.7717	1.7712	1.7717	1.7713	5 T	1.7717	1.7711	5 T	1.7717	1.7702	5 T	1.7717	1.7693	
50	1.9685	1.9680	1.9685	1.9681		1.9685	1.9679		1.9685	1.9670		1.9685	1.9661	
55	2.1654	2.1648	2.1654	2.1649		2.1654	2.1647		2.1654	2.1636		2.1654	2.1624	
60	2.3622	2.3616	2.3622	2.3617		2.3622	2.3615		2.3622	2.3604		2.3622	2.3592	
65	2.5591	2.5585	2.5591	2.5586	5 L	2.5591	2.5584	7 L	2.5591	2.5573	18 L	2.5591	2.5561	
70	2.7559	2.7553	2.7559	2.7554	6 T	2.7559	2.7552	6 T	2.7559	2.7541	6 T	2.7559	2.7529	
75	2.9528	2.9522	2.9528	2.9523		2.9528	2.9521		2.9528	2.9510		2.9528	2.9498	
80	3.1496	3.1490	3.1496	3.1491		3.1496	3.1489		3.1496	3.1478		3.1496	3.1466	
85	3.3465	3.3457	3.3465	3.3459		3.3465	3.3456		3.3465	3.3444		3.3465	3.3431	
90	3.5433	3.5425	3.5433	3.5427		3.5433	3.5424		3.5433	3.5412		3.5433	3.5399	
95	3.7402	3.7394	3.7402	3.7396		3.7402	3.7393		3.7402	3.7381		3.7402	3.7368	
100	3.9370	3.9362	3.9370	3.9364	6 L	3.9370	3.9361	9 L	3.9370	3.9349	21 L	3.9370	3.9336	
105	4.1339	4.1331	4.1339	4.1333	8 T	4.1339	4.1330	8 T	4.1339	4.1318	8 T	4.1339	4.1305	
110	4.3307	4.3299	4.3307	4.3301		4.3307	4.3298		4.3307	4.3286		4.3307	4.3273	
120	4.7244	4.7236	4.7244	4.7238		4.7244	4.7235		4.7244	4.7223		4.7244	4.7210	
130	5.1181	5.1171	5.1181	5.1174		5.1181	5.1171		5.1181	5.1156		5.1181	5.1142	
140	5.5118	5.5108	5.5118	5.5111		5.5118	5.5108		5.5118	5.5093		5.5118	5.5079	
150	5.9055	5.9045	5.9055	5.9048	7 L	5.9055	5.9045	10 L	5.9055	5.9030	25 L	5.9055	5.9016	
160	6.2992	6.2982	6.2992	6.2985	10 T	6.2992	6.2982	10 T	6.2992	6.2967	10 T	6.2992	6.2953	
170	6.6929	6.6919	6.6929	6.6922		6.6929	6.6919		6.6929	6.6904		6.6929	6.6890	
180	7.0866	7.0856	7.0866	7.0859		7.0866	7.0856		7.0866	7.0841		7.0866	7.0827	
190	7.4803	7.4791	7.4803	7.4795		7.4803	7.4792		7.4803	7.4775		7.4803	7.4758	
200	7.8740	7.8728	7.8740	7.8732	8 L	7.8740	7.8729	11 L	7.8740	7.8712	28 L	7.8740	7.8695	
220	8.6614	8.6602	8.6614	8.6606	12 T	8.6614	8.6603	12 T	8.6614	8.6586	12 T	8.6614	8.6569	
240	9.4488	9.4476	9.4488	9.4480		9.4488	9.4477		9.4488	9.4460		9.4488	9.4443	

¹⁾ Resultant fit in 0.0001 in. L indicates a clearance (loose) fit, T indicates an interference (tight) fit.

Shaft tolerances and resultant fits (inch)

Bearing bore diameter d	max		min		Resultant fits		h5		h6		h8		h9	
					Tolerance classes		Shaft diameter		Shaft diameter		Shaft diameter		Shaft diameter	
	mm	in.	in.	in.	Fit ¹⁾	in.	in.	in.	in.	in.	in.	in.	in.	Fit ¹⁾
260	10.2362	10.2348	10.2362	10.2353	9 L 14 T	10.2362	10.2349	13 L 14 T	10.2362	10.2330	32 L 14 T	10.2362	10.2311	51 L 14 T
280	11.0236	11.0222	11.0236	11.0227		11.0236	11.0223		11.0236	11.0204		11.0236	11.0185	
300	11.8110	11.8096	11.8110	11.8101		11.8110	11.8097		11.8110	11.8078		11.8110	11.8059	
320	12.5984	12.5968	12.5984	12.5974	10 L 16 T	12.5984	12.5970	14 L 16 T	12.5984	12.5949	35 L 16 T	12.5984	12.5929	55 L 16 T
340	13.3858	13.3842	13.3858	13.3848		13.3858	13.3844		13.3858	13.3823		13.3858	13.3803	
360	14.1732	14.1716	14.1732	14.1722		14.1732	14.1718		14.1732	14.1697		14.1732	14.1677	
380	14.9606	14.9590	14.9606	14.9596	11 L 18 T	14.9606	14.9592	16 L 18 T	14.9606	14.9571	38 L 18 T	14.9606	14.9551	61 L 18 T
400	15.7480	15.7464	15.7480	15.7470		15.7480	15.7466		15.7480	15.7445		15.7480	15.7425	
420	16.5354	16.5336	16.5354	16.5343		16.5354	16.5338		16.5354	16.5316		16.5354	16.5293	
440	17.3228	17.3210	17.3228	17.3217	12 L 18 T	17.3228	17.3212	17 L 18 T	17.3228	17.3190	43 L 18 T	17.3228	17.3167	68 L 18 T
460	18.1102	18.1084	18.1102	18.1091		18.1102	18.1086		18.1102	18.1064		18.1102	18.1041	
480	18.8976	18.8958	18.8976	18.8965		18.8976	18.8960		18.8976	18.8938		18.8976	18.8915	
500	19.6850	19.6832	19.6850	19.6839	13 L 20 T	19.6850	19.6834	20 L 20 T	19.6850	19.6812	20 T	19.6850	19.6789	20 T
530	20.8661	20.8641	–	–		20.8661	20.8644		20.8661	20.8618		20.8661	20.8593	
560	22.0472	22.0452	–	–		22.0472	22.0455		22.0472	22.0429		22.0472	22.0404	
600	23.6220	23.6200	–	–	23.6220	23.6203	23.6220	23.6177	23.6220	23.6152				
630	24.8031	24.8011	–	–	24.8031	24.8014	24.8031	24.7988	24.8031	24.7963				
670	26.3780	26.3750	–	–	26.3780	26.3760	26.3780	26.3731	26.3780	26.3701				
710	27.9528	27.9498	–	–	27.9528	27.9508	27.9528	27.9479	27.9528	27.9449				
750	29.5276	29.5246	–	–	29.5276	29.5256	29.5276	29.5227	29.5276	29.5197				
800	31.4961	31.4931	–	–	31.4961	31.4941	31.4961	31.4912	31.4961	31.4882				
850	33.4646	33.4607	–	–	33.4646	33.4624	33.4646	33.4591	33.4646	33.4555				
900	35.4331	35.4292	–	–	35.4331	35.4309	35.4331	35.4276	35.4331	35.4240				
950	37.4016	37.3977	–	–	37.4016	37.3994	37.4016	37.3961	37.4016	37.3925				
1000	39.3701	39.3662	–	–	39.3701	39.3679	39.3701	39.3646	39.3701	39.3610				
1060	41.7323	41.7274	–	–	41.7323	41.7297	41.7323	41.7258	41.7323	41.7221				
1120	44.0945	44.0896	–	–	44.0945	44.0919	44.0945	44.0880	44.0945	44.0843				
1180	46.4567	46.4518	–	–	46.4567	46.4541	46.4567	46.4502	46.4567	46.4465				
1250	49.2126	49.2077	–	–	49.2126	49.2100	49.2126	49.2061	49.2126	49.2024				

¹⁾ Resultant fit in 0.0001 in. L indicates a clearance (loose) fit, T indicates an interference (tight) fit.

Shaft tolerances and resultant fits (inch)

Bearing bore diameter d	max		min		Resultant fits Tolerance classes		j5		j6		js4		js5		Fit ¹⁾	
	max	min	max	min	Shaft diameter	Fit ¹⁾	Shaft diameter	Fit ¹⁾	Shaft diameter	Fit ¹⁾	Shaft diameter	Fit ¹⁾	Shaft diameter	Fit ¹⁾	Shaft diameter	Fit ¹⁾
mm	in.				in.	-	in.	-	in.	-	in.	-	in.	-	in.	-
4	0.1575	0.1572	0.1576	0.1574		1 L	0.1577	0.1574	1 L	-	-	-	0.1576	0.1574	1 L	
5	0.1969	0.1966	0.1970	0.1968		4 T	0.1971	0.1968	5 T	-	-	-	0.1970	0.1968	4 T	
6	0.2362	0.2359	0.2363	0.2361			0.2364	0.2361		-	-	-	0.2363	0.2361		
7	0.2756	0.2753	0.2758	0.2755			0.2759	0.2755		0.2757	0.2755	1 L	0.2757	0.2755	1 L	
8	0.3150	0.3147	0.3152	0.3149		1 L	0.3153	0.3149	1 L	0.3151	0.3149	1 L	0.3151	0.3149	1 L	
9	0.3543	0.3540	0.3545	0.3542		5 T	0.3546	0.3542	6 T	0.3544	0.3542	4 T	0.3544	0.3542	4 T	
10	0.3937	0.3934	0.3939	0.3936			0.3940	0.3936		0.3938	0.3936		0.3938	0.3936		
12	0.4724	0.4721	0.4726	0.4723		1 L	0.4727	0.4723	1 L	0.4725	0.4723	1 L	0.4726	0.4722	2 L	
15	0.5906	0.5903	0.5908	0.5905		5 T	0.5909	0.5905	6 T	0.5907	0.5905	4 T	0.5908	0.5904	5 T	
17	0.6693	0.6690	0.6695	0.6692			0.6696	0.6692		0.6694	0.6692		0.6695	0.6691		
20	0.7874	0.7870	0.7876	0.7872		2 L	0.7878	0.7872	2 L	0.7875	0.7872	2 L	0.7876	0.7872	2 L	
25	0.9843	0.9839	0.9845	0.9841		6 T	0.9847	0.9841	8 T	0.9844	0.9841	5 T	0.9845	0.9841	6 T	
30	1.1811	1.1807	1.1813	1.1809			1.1815	1.1809		1.1812	1.1809		1.1813	1.1809		
35	1.3780	1.3775	1.3782	1.3778			1.3784	1.3778		1.3781	1.3778		1.3782	1.3778		
40	1.5748	1.5743	1.5750	1.5746		2 L	1.5752	1.5746	2 L	1.5749	1.5746	2 L	1.5750	1.5746	2 L	
45	1.7717	1.7712	1.7719	1.7715		7 T	1.7721	1.7715	9 T	1.7718	1.7715	6 T	1.7719	1.7715	7 T	
50	1.9685	1.9680	1.9687	1.9683			1.9689	1.9683		1.9686	1.9683		1.9687	1.9683		
55	2.1654	2.1648	2.1656	2.1651			2.1659	2.1651		2.1655	2.1652		2.1656	2.1651		
60	2.3622	2.3616	2.3624	2.3619			2.3627	2.3619		2.3623	2.3620		2.3624	2.3619		
65	2.5591	2.5585	2.5593	2.5588		3 L	2.5596	2.5588	3 L	2.5592	2.5589	2 L	2.5593	2.5588	3 L	
70	2.7559	2.7553	2.7561	2.7556		8 T	2.7564	2.7556	11 T	2.7560	2.7557	7 T	2.7561	2.7556	8 T	
75	2.9528	2.9522	2.9530	2.9525			2.9533	2.9525		2.9529	2.9526		2.9530	2.9525		
80	3.1496	3.1490	3.1498	3.1493			3.1501	3.1493		3.1497	3.1494		3.1498	3.1493		
85	3.3465	3.3457	3.3467	3.3461			3.3470	3.3461		3.3467	3.3463		3.3468	3.3462		
90	3.5433	3.5425	3.5435	3.5429			3.5438	3.5429		3.5435	3.5431		3.5436	3.5430		
95	3.7402	3.7394	3.7404	3.7398			3.7407	3.7398		3.7404	3.7400		3.7405	3.7399		
100	3.9370	3.9362	3.9372	3.9366		4 L	3.9375	3.9366	4 L	3.9372	3.9368	2 L	3.9373	3.9367	3 L	
105	4.1339	4.1331	4.1341	4.1335		10 T	4.1344	4.1335	13 T	4.1341	4.1337	10 T	4.1342	4.1336	11 T	
110	4.3307	4.3299	4.3309	4.3303			4.3312	4.3303		4.3309	4.3305		4.3310	4.3304		
120	4.7244	4.7236	4.7246	4.7240			4.7249	4.7240		4.7246	4.7242		4.7247	4.7241		
130	5.1181	5.1171	5.1184	5.1177			5.1187	5.1177		5.1183	5.1178		5.1184	5.1177		
140	5.5118	5.5108	5.5121	5.5114			5.5124	5.5114		5.5120	5.5115		5.5121	5.5114		
150	5.9055	5.9045	5.9058	5.9051		4 L	5.9061	5.9051	4 L	5.9057	5.9052	3 L	5.9058	5.9051	4 L	
160	6.2992	6.2982	6.2995	6.2988		13 T	6.2998	6.2988	16 T	6.2994	6.2989	12 T	6.2995	6.2988	13 T	
170	6.6929	6.6919	6.6932	6.6925			6.6935	6.6925		6.6931	6.6926		6.6932	6.6925		
180	7.0866	7.0856	7.0869	7.0862			7.0872	7.0862		7.0868	7.0863		7.0869	7.0862		
190	7.4803	7.4791	7.4806	7.4798			7.4809	7.4798		7.4806	7.4800		7.4807	7.4799		
200	7.8740	7.8728	7.8743	7.8735		5 L	7.8746	7.8735	5 L	7.8743	7.8737	3 L	7.8744	7.8736	4 L	
220	8.6614	8.6602	8.6617	8.6609		15 T	8.6620	8.6609	18 T	8.6617	8.6611	15 T	8.6618	8.6610	16 T	
240	9.4488	9.4476	9.4491	9.4483			9.4494	9.4483		9.4491	9.4485		9.4492	9.4484		

¹⁾ Resultant fit in 0.0001 in. L indicates a clearance (loose) fit, T indicates an interference (tight) fit.

Shaft tolerances and resultant fits (inch)

Bearing bore diameter d	max		min		Resultant fits Tolerance classes j5 Shaft diameter		Fit ¹⁾	j6 Shaft diameter		Fit ¹⁾	js4 Shaft diameter		Fit ¹⁾	js5 Shaft diameter		Fit ¹⁾
	max	min	max	min	max	min		max	min		max	min		max	min	
mm	in.		in.				-	in.		-	in.		-	in.		-
260	10.2362	10.2348	10.2365	10.2356	6 L 17 T	10.2368	10.2356	6 L 20 T	10.2365	10.2359	3 L 17 T	10.2366	10.2357	5 L 18 T		
280	11.0236	11.0222	11.0239	11.0230		11.0242	11.0230		11.0239	11.0233		11.0240	11.0231			
300	11.8110	11.8096	11.8113	11.8104		11.8116	11.8104		11.8113	11.8107		11.8114	11.8105			
320	12.5984	12.5968	12.5987	12.5977	7 L 19 T	12.5991	12.5977	7 L 23 T	-	-	-	12.5989	12.5979	5 L 21 T		
340	13.3858	13.3842	13.3861	13.3851		13.3865	13.3851		-	-		13.3863	13.3853			
360	14.1732	14.1716	14.1735	14.1725		14.1739	14.1725		-	-		14.1737	14.1727			
380	14.9606	14.9590	14.9609	14.9599		14.9613	14.9599		-	-		14.9611	14.9601			
400	15.7480	15.7464	15.7483	15.7473		15.7487	15.7473		-	-		15.7485	15.7475			
420	16.5354	16.5336	16.5357	16.5346	8 L 21 T	16.5362	16.5346	8 L 26 T	-	-	-	16.5359	16.5349	5 L 23 T		
440	17.3228	17.3210	17.3231	17.3220		17.3236	17.3220		-	-		17.3233	17.3223			
460	18.1102	18.1084	18.1105	18.1094		18.1110	18.1094		-	-		18.1107	18.1097			
480	18.8976	18.8958	18.8979	18.8968		18.8984	18.8968		-	-		18.8981	18.8971			
500	19.6850	19.6832	19.6853	19.6842		19.6858	19.6842		-	-		19.6855	19.6845			
530	20.8661	20.8641	-	-	-	20.8670	20.8652	9 L 29 T	-	-	-	20.8666	20.8655	6 L 25 T		
560	22.0472	22.0452	-	-		22.0481	22.0463		-	-		22.0477	22.0466			
600	23.6220	23.6200	-	-		23.6229	23.6211		-	-		23.6225	23.6214			
630	24.8031	24.8011	-	-		24.8040	24.8022		-	-		24.8036	24.8025			
670	26.3780	26.3750	-	-	-	26.3790	26.3770	10 L 40 T	-	-	-	26.3786	26.3774	6 L 36 T		
710	27.9528	27.9498	-	-		27.9538	27.9518		-	-		27.9534	27.9522			
750	29.5276	29.5246	-	-		29.5286	29.5266		-	-		29.5282	29.5270			
800	31.4961	31.4931	-	-		31.4971	31.4951		-	-		31.4967	31.4955			
850	33.4646	33.4607	-	-	-	33.4657	33.4635	11 L 50 T	-	-	-	33.4653	33.4639	7 L 46 T		
900	35.4331	35.4292	-	-		35.4342	35.4320		-	-		35.4338	35.4324			
950	37.4016	37.3977	-	-		37.4027	37.4005		-	-		37.4023	37.4009			
1000	39.3701	39.3662	-	-		39.3712	39.3690		-	-		39.3708	39.3694			
1060	41.7323	41.7274	-	-	-	41.7336	41.7310	13 L 62 T	-	-	-	41.7331	41.7315	8 L 57 T		
1120	44.0945	44.0896	-	-		44.0958	44.0932		-	-		44.0953	44.0937			
1180	46.4567	46.4518	-	-		46.4580	46.4554		-	-		46.4575	46.4559			
1250	49.2126	49.2077	-	-		49.2139	49.2113		-	-		49.2134	49.2118			

¹⁾ Resultant fit in 0.0001 in. L indicates a clearance (loose) fit, T indicates an interference (tight) fit.

Shaft tolerances and resultant fits (inch)

Bearing bore diameter d	Resultant fits Tolerance classes		js6		js7		k4		k5					
			Shaft diameter		Fit ¹⁾	Shaft diameter		Fit ¹⁾	Shaft diameter		Fit ¹⁾	Shaft diameter		
	max	min	max	min		max	min		max	min		max	min	
mm	in.	in.		-	in.		-	in.		-	in.		-	
4	0.1575	0.1572	0.1577	0.1573	2 L	0.1577	0.1572	3 T	0.1577	0.1575	0 T	0.1577	0.1575	0 T
5	0.1969	0.1966	0.1971	0.1967	5 T	0.1971	0.1966	5 T	0.1971	0.1969	5 T	0.1971	0.1969	5 T
6	0.2362	0.2359	0.2364	0.2360		0.2364	0.2359		0.2364	0.2362		0.2364	0.2362	
7	0.2756	0.2753	0.2758	0.2754		0.2759	0.2753		0.2758	0.2756		0.2759	0.2756	
8	0.3150	0.3147	0.3152	0.3148	2 L	0.3153	0.3147	3 T	0.3152	0.3150	0 T	0.3153	0.3150	0 T
9	0.3543	0.3540	0.3545	0.3541	5 T	0.3546	0.3540	6 T	0.3545	0.3543	5 T	0.3546	0.3543	6 T
10	0.3937	0.3934	0.3939	0.3935		0.3940	0.3934		0.3939	0.3937		0.3940	0.3937	
12	0.4724	0.4721	0.4726	0.4722	2 L	0.4727	0.4720	4 T	0.4727	0.4724	0 T	0.4728	0.4724	0 T
15	0.5906	0.5903	0.5908	0.5904	5 T	0.5909	0.5902	6 T	0.5909	0.5906	6 T	0.5910	0.5906	7 T
17	0.6693	0.6690	0.6695	0.6691		0.6696	0.6689		0.6696	0.6693		0.6697	0.6693	
20	0.7874	0.7870	0.7876	0.7871	3 L	0.7878	0.7870	4 T	0.7877	0.7874	0 T	0.7878	0.7875	1 T
25	0.9843	0.9839	0.9845	0.9840	6 T	0.9847	0.9839	8 T	0.9846	0.9843	7 T	0.9847	0.9844	8 T
30	1.1811	1.1807	1.1813	1.1808		1.1815	1.1807		1.1814	1.1811		1.1815	1.1812	
35	1.3780	1.3775	1.3783	1.3777		1.3784	1.3775		1.3783	1.3781		1.3785	1.3781	
40	1.5748	1.5743	1.5751	1.5745	3 L	1.5752	1.5743	5 T	1.5751	1.5749	1 T	1.5753	1.5749	1 T
45	1.7717	1.7712	1.7720	1.7714	8 T	1.7721	1.7712	9 T	1.7720	1.7718	8 T	1.7722	1.7718	10 T
50	1.9685	1.9680	1.9688	1.9682		1.9689	1.9680		1.9688	1.9686		1.9690	1.9686	
55	2.1654	2.1648	2.1658	2.1650		2.1659	2.1648		2.1658	2.1655		2.1660	2.1655	
60	2.3622	2.3616	2.3626	2.3618		2.3627	2.3616		2.3626	2.3623		2.3628	2.3623	
65	2.5591	2.5585	2.5595	2.5587	4 L	2.5596	2.5585	6 T	2.5595	2.5592	1 T	2.5597	2.5592	1 T
70	2.7559	2.7553	2.7563	2.7555	10 T	2.7564	2.7553	11 T	2.7563	2.7560	10 T	2.7565	2.7560	12 T
75	2.9528	2.9522	2.9532	2.9524		2.9533	2.9522		2.9532	2.9529		2.9534	2.9529	
80	3.1496	3.1490	3.1500	3.1492		3.1501	3.1490		3.1500	3.1497		3.1502	3.1497	
85	3.3465	3.3457	3.3469	3.3461		3.3472	3.3458		3.3470	3.3466		3.3472	3.3466	
90	3.5433	3.5425	3.5437	3.5429		3.5440	3.5426		3.5438	3.5434		3.5440	3.5434	
95	3.7402	3.7394	3.7406	3.7398		3.7409	3.7395		3.7407	3.7403		3.7409	3.7403	
100	3.9370	3.9362	3.9374	3.9366	4 L	3.9377	3.9363	7 T	3.9375	3.9371	1 T	3.9377	3.9371	1 T
105	4.1339	4.1331	4.1343	4.1335	12 T	4.1346	4.1332	15 T	4.1344	4.1340	13 T	4.1346	4.1340	15 T
110	4.3307	4.3299	4.3311	4.3303		4.3314	4.3300		4.3312	4.3308		4.3314	4.3308	
120	4.7244	4.7236	4.7248	4.7240		4.7251	4.7237		4.7249	4.7245		4.7251	4.7245	
130	5.1181	5.1171	5.1186	5.1176		5.1189	5.1173		5.1187	5.1182		5.1189	5.1182	
140	5.5118	5.5108	5.5123	5.5113		5.5126	5.5110		5.5124	5.5119		5.5126	5.5119	
150	5.9055	5.9045	5.9060	5.9050	5 L	5.9063	5.9047	8 T	5.9061	5.9056	1 T	5.9063	5.9056	1 T
160	6.2992	6.2982	6.2997	6.2987	15 T	6.3000	6.2984	18 T	6.2998	6.2993	16 T	6.3000	6.2993	18 T
170	6.6929	6.6919	6.6934	6.6924		6.6937	6.6921		6.6935	6.6930		6.6937	6.6930	
180	7.0866	7.0856	7.0871	7.0861		7.0874	7.0858		7.0872	7.0867		7.0874	7.0867	
190	7.4803	7.4791	7.4809	7.4797		7.4812	7.4794		7.4810	7.4805		7.4812	7.4805	
200	7.8740	7.8728	7.8746	7.8734	6 L	7.8749	7.8731	9 T	7.8747	7.8742	2 T	7.8749	7.8742	2 T
220	8.6614	8.6602	8.6620	8.6608	18 T	8.6623	8.6605	21 T	8.6621	8.6616	19 T	8.6623	8.6616	21 T
240	9.4488	9.4476	9.4494	9.4482		9.4497	9.4479		9.4495	9.4490		9.4497	9.4490	

¹⁾ Resultant fit in 0.0001 in. L indicates a clearance (loose) fit, T indicates an interference (tight) fit.

Shaft tolerances and resultant fits (inch)

Bearing bore diameter d	max		min		Resultant fits Tolerance classes		js7		k4		k5		Fit ¹⁾			
	Shaft diameter		Shaft diameter		Fit ¹⁾	Shaft diameter		Shaft diameter		Fit ¹⁾	Shaft diameter					
	max	min	max	min		max	min	max	min		max	min				
mm	in.		in.		-	in.		-	in.	-	in.	-				
260	10.2362	10.2348	10.2368	10.2356	6 L 20 T	10.2372	10.2352	10 T 24 T	10.2370	10.2364	2 T 22 T	10.2373	10.2364	2 T 25 T		
280	11.0236	11.0222	11.0242	11.0230		11.0246	11.0226		11.0244	11.0238		11.0247	11.0238		11.0247	11.0238
300	11.8110	11.8096	11.8116	11.8104		11.8120	11.8100		11.8118	11.8112		11.8127	11.8112		11.8127	11.8112
320	12.5984	12.5968	12.5991	12.5977	7 L 23 T	12.5996	12.5973	11 T 28 T	12.5992	12.5986	2 T 24 T	12.5995	12.5986	2 T 27 T		
340	13.3858	13.3842	13.3865	13.3851		13.3870	13.3847		13.3866	13.3860		13.3869	13.3860		13.3869	13.3860
360	14.1732	14.1716	14.1739	14.1725		14.1744	14.1721		14.1740	14.1734		14.1743	14.1734		14.1743	14.1734
380	14.9606	14.9590	14.9613	14.9599		14.9618	14.9595		14.9614	14.9608		14.9617	14.9608		14.9617	14.9608
400	15.7480	15.7464	15.7487	15.7473		15.7492	15.7469		15.7488	15.7482		15.7497	15.7482		15.7497	15.7482
420	16.5354	16.5336	16.5362	16.5346	8 L 26 T	16.5367	16.5342	12 T 31 T	16.5364	16.5356	2 T 28 T	16.5367	16.5356	2 T 31 T		
440	17.3228	17.3210	17.3236	17.3220		17.3241	17.3216		17.3238	17.3230		17.3241	17.3230		17.3241	17.3230
460	18.1102	18.1084	18.1110	18.1094		18.1115	18.1090		18.1112	18.1104		18.1115	18.1104		18.1115	18.1104
480	18.8976	18.8958	18.8984	18.8968		18.8989	18.8964		18.8986	18.8978		18.8989	18.8978		18.8989	18.8978
500	19.6850	19.6832	19.6858	19.6842		19.6863	19.6838		19.6860	19.6852		19.6863	19.6852		19.6863	19.6852
530	20.8661	20.8641	20.8669	20.8652		9 L	20.8675		20.8648	-		-	-		20.8673	20.8661
560	22.0472	22.0452	22.0480	22.0463	28 T	22.0486	22.0459	13 T	-	-	-	22.0484	22.0472	0 T		
600	23.6220	23.6200	23.6228	23.6211		23.6234	23.6207	34 T	-	-	-	23.6232	23.6220	32 T		
630	24.8031	24.8011	24.8039	24.8022		24.8045	24.8018	-	-	-	-	24.8043	24.8031	-		
670	26.3780	26.3750	26.3789	26.3770	10 L 39 T	26.3795	26.3764	-	-	-	26.3794	26.3780	-			
710	27.9528	27.9498	27.9537	27.9518		27.9543	27.9512	16 T	-	-	-	27.9542	27.9528	0 T		
750	29.5276	29.5246	29.5285	29.5266		29.5291	29.5260	45 T	-	-	-	29.5290	29.5276	44 T		
800	31.4961	31.4931	31.4970	31.4951		31.4976	31.4945	-	-	-	-	31.4975	31.4961	-		
850	33.4646	33.4607	33.4657	33.4635	11 L 50 T	33.4663	33.4628	-	-	-	33.4662	33.4646	-			
900	35.4331	35.4292	35.4342	35.4320		35.4348	35.4313	18 T	-	-	-	35.4347	35.4331	0 T		
950	37.4016	37.3977	37.4027	37.4005		37.4033	37.3998	56 T	-	-	-	37.4032	37.4016	55 T		
1000	39.3701	39.3662	39.3712	39.3690		39.3718	39.3683	-	-	-	-	39.3717	39.3701	-		
1060	41.7323	41.7274	41.7336	41.7310	13 L 62 T	41.7343	41.7302	-	-	-	41.7341	41.7323	-			
1120	44.0945	44.0896	44.0958	44.0932		44.0965	44.0924	21 T	-	-	-	44.0963	44.0945	0 T		
1180	46.4567	46.4518	46.4580	46.4554		46.4587	46.4546	69 T	-	-	-	46.4585	46.4567	67 T		
1250	49.2126	49.2077	49.2139	49.2113	-	49.2146	49.2105	-	-	-	49.2144	49.2126	-			

¹⁾ Resultant fit in 0.0001 in. L indicates a clearance (loose) fit, T indicates an interference (tight) fit.

Shaft tolerances and resultant fits (inch)

Bearing bore diameter d	Resultant fits		Tolerance classes		k6		m5		m6		n5		Fit ¹⁾	
			Shaft diameter		Shaft diameter		Shaft diameter		Shaft diameter		Shaft diameter		Fit ¹⁾	
	max	min	max	min	max	min	max	min	max	min	max	min	max	min
mm	in.	in.	in.	–	in.	–	in.	–	in.	–	in.	–	in.	–
4	0.1575	0.1572	0.1579	0.1575	0 T	0.1579	0.1577	2 T	0.1580	0.1577	2 T	0.1580	0.1578	3 T
5	0.1969	0.1966	0.1973	0.1969	7 T	0.1973	0.1971	7 T	0.1974	0.1971	8 T	0.1974	0.1972	8 T
6	0.2362	0.2359	0.2366	0.2362		0.2366	0.2364		0.2367	0.2364		0.2367	0.2365	
7	0.2756	0.2753	0.2760	0.2756		0.2761	0.2758	2 T	0.2762	0.2758	2 T	0.2762	0.2760	4 T
8	0.3150	0.3147	0.3154	0.3150	0 T	0.3155	0.3152	2 T	0.3156	0.3152	2 T	0.3156	0.3154	4 T
9	0.3543	0.3540	0.3547	0.3543	7 T	0.3548	0.3545	8 T	0.3549	0.3545	9 T	0.3549	0.3547	9 T
10	0.3937	0.3934	0.3941	0.3937		0.3942	0.3939		0.3943	0.3939		0.3943	0.3941	
12	0.4724	0.4721	0.4729	0.4724	0 T	0.4730	0.4727	3 T	0.4731	0.4727	3 T	0.4732	0.4729	5 T
15	0.5906	0.5903	0.5911	0.5906	8 T	0.5912	0.5909	9 T	0.5913	0.5909	10 T	0.5914	0.5911	11 T
17	0.6693	0.6690	0.6698	0.6693		0.6699	0.6696		0.6700	0.6696		0.6701	0.6698	
20	0.7874	0.7870	0.7880	0.7875	1 T	0.7881	0.7877	3 T	0.7882	0.7877	3 T	0.7883	0.7880	6 T
25	0.9843	0.9839	0.9849	0.9844	10 T	0.9850	0.9846	11 T	0.9851	0.9846	12 T	0.9852	0.9849	13 T
30	1.1811	1.1807	1.1817	1.1812		1.1818	1.1814		1.1819	1.1814		1.1820	1.1817	
35	1.3780	1.3775	1.3787	1.3781		1.3788	1.3784	4 T	1.3790	1.3784	4 T	1.3791	1.3787	7 T
40	1.5748	1.5743	1.5755	1.5749	1 T	1.5756	1.5752	4 T	1.5758	1.5752	4 T	1.5759	1.5755	7 T
45	1.7717	1.7712	1.7724	1.7718	12 T	1.7725	1.7721	13 T	1.7727	1.7721	15 T	1.7728	1.7724	16 T
50	1.9685	1.9680	1.9692	1.9686		1.9693	1.9689		1.9695	1.9689		1.9696	1.9692	
55	2.1654	2.1648	2.1662	2.1655		2.1663	2.1658		2.1666	2.1658		2.1667	2.1662	
60	2.3622	2.3616	2.3630	2.3623		2.3631	2.3626		2.3634	2.3626		2.3635	2.3630	
65	2.5591	2.5585	2.5599	2.5592	1 T	2.5600	2.5595	4 T	2.5603	2.5595	4 T	2.5604	2.5599	8 T
70	2.7559	2.7553	2.7567	2.7560	14 T	2.7568	2.7563	15 T	2.7571	2.7563	18 T	2.7572	2.7567	19 T
75	2.9528	2.9522	2.9536	2.9529		2.9537	2.9532		2.9540	2.9532		2.9541	2.9536	
80	3.1496	3.1490	3.1504	3.1497		3.1505	3.1500		3.1508	3.1500		3.1509	3.1504	
85	3.3465	3.3457	3.3475	3.3466		3.3476	3.3470		3.3479	3.3470		3.3480	3.3474	
90	3.5433	3.5425	3.5443	3.5434		3.5444	3.5438		3.5447	3.5438		3.5448	3.5442	
95	3.7402	3.7394	3.7412	3.7403		3.7413	3.7407		3.7416	3.7407		3.7417	3.7411	
100	3.9370	3.9362	3.9380	3.9371	1 T	3.9381	3.9375	5 T	3.9384	3.9375	5 T	3.9385	3.9379	9 T
105	4.1339	4.1331	4.1349	4.1340	18 T	4.1350	4.1344	19 T	4.1353	4.1344	22 T	4.1354	4.1348	23 T
110	4.3307	4.3299	4.3317	4.3308		4.3318	4.3312		4.3321	4.3312		4.3322	4.3316	
120	4.7244	4.7236	4.7254	4.7245		4.7255	4.7249		4.7258	4.7249		4.7259	4.7253	
130	5.1181	5.1171	5.1192	5.1182		5.1194	5.1187		5.1197	5.1187		5.1199	5.1192	
140	5.5118	5.5108	5.5129	5.5119		5.5131	5.5124		5.5134	5.5124		5.5136	5.5129	
150	5.9055	5.9045	5.9066	5.9056	1 T	5.9068	5.9061	6 T	5.9071	5.9061	6 T	5.9073	5.9066	11 T
160	6.2992	6.2982	6.3003	6.2993	21 T	6.3005	6.2998	23 T	6.3008	6.2998	26 T	6.3010	6.3003	28 T
170	6.6929	6.6919	6.6940	6.6930		6.6942	6.6935		6.6945	6.6935		6.6947	6.6940	
180	7.0866	7.0856	7.0877	7.0867		7.0879	7.0872		7.0882	7.0872		7.0884	7.0877	
190	7.4803	7.4791	7.4815	7.4805		7.4818	7.4810		7.4821	7.4810		7.4823	7.4815	
200	7.8740	7.8728	7.8753	7.8742	2 T	7.8755	7.8747	7 T	7.8758	7.8747	7 T	7.8760	7.8752	12 T
220	8.6614	8.6602	8.6627	8.6616	25 T	8.6629	8.6621	27 T	8.6632	8.6621	30 T	8.6634	8.6626	32 T
240	9.4488	9.4476	9.4501	9.4490		9.4503	9.4495		9.4506	9.4495		9.4508	9.4500	

¹⁾ Resultant fit in 0.0001 in. L indicates a clearance (loose) fit, T indicates an interference (tight) fit.

Shaft tolerances and resultant fits (inch)

Bearing bore diameter d	max		min		Resultant fits		m5		m6		n5		Fit ¹⁾			
					Tolerance classes		Shaft diameter		Shaft diameter		Shaft diameter			Shaft diameter		
	mm	in.	in.	in.	–	in.	–	in.	–	in.	–	–				
260	10.2362	10.2348	10.2376	10.2364	2T 28 T	10.2379	10.2370	8T 31 T	10.2382	10.2370	8T 34 T	10.2384	10.2375	13 T 36 T		
280	11.0236	11.0222	11.0250	11.0238		11.0253	11.0244		11.0256	11.0244		11.0258	11.0249		11.0258	11.0249
300	11.8110	11.8096	11.8124	11.8112		11.8127	11.8118		11.8130	11.8118		11.8132	11.8123			
320	12.5984	12.5968	12.6000	12.5986	2T 32 T	12.6002	12.5992	8T 34 T	12.6006	12.5992	8T 38 T	12.6008	12.5999	15 T 40 T		
340	13.3858	13.3842	13.3874	13.3860		13.3876	13.3866		13.3880	13.3866		13.3882	13.3873			
360	14.1732	14.1716	14.1748	14.1734		14.1750	14.1740		14.1754	14.1740		14.1756	14.1747			
380	14.9606	14.9590	14.9622	14.9608		14.9624	14.9614		14.9628	14.9614		14.9630	14.9621			
400	15.7480	15.7464	15.7496	15.7482		15.7498	15.7488		15.7502	15.7488		15.7504	15.7495			
420	16.5354	16.5336	16.5372	16.5356	2T 36 T	16.5374	16.5363	9T 38 T	16.5379	16.5363	9T 43 T	16.5380	16.5370	16 T 44 T		
440	17.3228	17.3210	17.3246	17.3230		17.3248	17.3237		17.3253	17.3237		17.3254	17.3244			
460	18.1102	18.1084	18.1120	18.1104		18.1122	18.1111		18.1127	18.1111		18.1128	18.1118			
480	18.8976	18.8958	18.8994	18.8978		18.8996	18.8985		18.9001	18.8985		18.9002	18.8992			
500	19.6850	19.6832	19.6868	19.6852		19.6870	19.6859		19.6875	19.6859		19.6876	19.6866			
530	20.8661	20.8641	20.8678	20.8661		20.8683	20.8671		–	–		20.8689	20.8678			
560	22.0472	22.0452	22.0489	22.0472		0T	22.0494		22.0482	10 T		–	–		–	22.0500
600	23.6220	23.6200	23.6237	23.6220	37 T	23.6242	23.6230	42 T	–	–	–	23.6248	23.6237	48 T		
630	24.8031	24.8011	24.8048	24.8031		24.8053	24.8041		–	–	–	24.8059	24.8048			
670	26.3780	26.3750	26.3799	26.3780		26.3806	26.3792		–	–	–	26.3812	26.3800			
710	27.9528	27.9498	27.9547	27.9528	0T	27.9554	27.9540	12 T	–	–	–	27.9560	27.9548	20 T		
750	29.5276	29.5246	29.5295	29.5276	49 T	29.5302	29.5288	56 T	–	–	–	29.5308	29.5296	62 T		
800	31.4961	31.4931	31.4980	31.4961		31.4987	31.4973		–	–	–	31.4993	31.4981			
850	33.4646	33.4607	33.4668	33.4646		33.4675	33.4659		–	–	–	33.4683	33.4668			
900	35.4331	35.4292	35.4353	35.4331	0T	35.4360	35.4344	13 T	–	–	–	35.4368	35.4353	22 T		
950	37.4016	37.3977	37.4038	37.4016	61 T	37.4045	37.4029	68 T	–	–	–	37.4053	37.4038	76 T		
1000	39.3701	39.3662	39.3723	39.3701		39.3730	39.3714		–	–	–	39.3738	39.3723			
1060	41.7323	41.7274	41.7349	41.7323		41.7357	41.7339		–	–	–	41.7366	41.7349			
1120	44.0945	44.0896	44.0971	44.0945	0T	44.0979	44.0961	16 T	–	–	–	44.0988	44.0971	26 T		
1180	46.4567	46.4518	46.4593	46.4567	75 T	46.4601	46.4583	83 T	–	–	–	46.4610	46.4593	92 T		
1250	49.2126	49.2077	49.2152	49.2126		49.2160	49.2142		–	–	–	49.2169	49.2152			

¹⁾ Resultant fit in 0.0001 in. L indicates a clearance (loose) fit, T indicates an interference (tight) fit.

Shaft tolerances and resultant fits (inch)

Bearing bore diameter d	max		min		Resultant fits Tolerance classes			p6			p7			r6							
	Shaft diameter		Shaft diameter		Fit ⁽¹⁾			Shaft diameter		Fit ⁽¹⁾		Shaft diameter		Fit ⁽¹⁾		Shaft diameter		Fit ⁽¹⁾			
	max	min	max	min	max	min	max	min	max	min	max	min	max	min	max	min	max	min	max	min	
mm	in.	mm	in.	in.		in.		in.		in.		in.		in.		in.		in.		in.	
85	3.3465	3.3457	3.3483	3.3474					3.3488	3.3480			3.3493	3.3480							
90	3.5433	3.5425	3.5451	3.5442					3.5456	3.5448			3.5461	3.5448							
95	3.7402	3.7394	3.7420	3.7411					3.7425	3.7417			3.7430	3.7417							
100	3.9370	3.9362	3.9388	3.9379					3.9393	3.9385			3.9398	3.9385							
105	4.1339	4.1331	4.1357	4.1348					4.1362	4.1354			4.1367	4.1354							
110	4.3307	4.3299	4.3325	4.3316					4.3330	4.3322			4.3335	4.3322							
120	4.7244	4.7236	4.7262	4.7253					4.7267	4.7259			4.7272	4.7259							
130	5.1181	5.1171	5.1201	5.1192					5.1208	5.1198			5.1214	5.1198			5.1216	5.1207			
140	5.5118	5.5108	5.5138	5.5129					5.5145	5.5135			5.5151	5.5135			5.5153	5.5144			
150	5.9055	5.9045	5.9075	5.9066					5.9082	5.9072			5.9088	5.9072			5.9090	5.9081			26 T
160	6.2992	6.2982	6.3012	6.3003					6.3019	6.3009			6.3025	6.3009			6.3027	6.3018			45 T
170	6.6929	6.6919	6.6949	6.6940					6.6956	6.6946			6.6962	6.6946			6.6964	6.6955			
180	7.0866	7.0856	7.0886	7.0877					7.0893	7.0883			7.0899	7.0883			7.0901	7.0892			
190	7.4803	7.4791	7.4827	7.4815					7.4834	7.4823			7.4841	7.4823			7.4845	7.4833			30 T
200	7.8740	7.8728	7.8764	7.8752					7.8771	7.8760			7.8778	7.8760			7.8782	7.8770			54 T
220	8.6614	8.6602	8.6638	8.6626					8.6645	8.6634			8.6652	8.6634			8.6657	8.6645			31T/55T
240	9.4488	9.4476	9.4512	9.4500					9.4519	9.4508			9.4526	9.4508			9.4532	9.4521			33 T
260	10.2362	10.2348	10.2388	10.2375					10.2397	10.2384			10.2405	10.2384			10.2412	10.2399			37 T
280	11.0236	11.0222	11.0262	11.0249					11.0271	11.0258			11.0279	11.0258			11.0286	11.0273			64 T
300	11.8110	11.8096	11.8136	11.8123					11.8145	11.8132			11.8153	11.8132			11.8161	11.8149			39T/65T
320	12.5984	12.5968	12.6013	12.5999					12.6023	12.6008			12.6031	12.6009			12.6041	12.6027			43 T
340	13.3858	13.3842	13.3887	13.3873					13.3897	13.3882			13.3905	13.3883			13.3915	13.3901			73 T
360	14.1732	14.1716	14.1761	14.1747					14.1771	14.1756			14.1779	14.1757			14.1791	14.1777			45 T
380	14.9606	14.9590	14.9635	14.9621					14.9645	14.9630			14.9653	14.9631			14.9665	14.9651			75 T
400	15.7480	15.7464	15.7509	15.7495					15.7519	15.7504			15.7527	15.7505			15.7539	15.7525			
420	16.5354	16.5336	16.5385	16.5370					16.5397	16.5381			16.5406	16.5381			16.5419	16.5404			50 T
440	17.3228	17.3210	17.3259	17.3244					17.3271	17.3255			17.3280	17.3255			17.3293	17.3278			83 T
460	18.1102	18.1084	18.1133	18.1118					18.1145	18.1129			18.1154	18.1129			18.1170	18.1154			
480	18.8976	18.8958	18.9007	18.8992					18.9019	18.9003			18.9028	18.9003			18.9044	18.9028			52 T
500	19.6850	19.6832	19.6881	19.6866					19.6893	19.6877			19.6902	19.6877			19.6918	19.6902			86 T
530	20.8661	20.8641	20.8696	20.8678					20.8709	20.8692			20.8720	20.8692			20.8737	20.8720			59 T
560	22.0472	22.0452	22.0507	22.0489					22.0520	22.0503			22.0531	22.0503			22.0548	22.0531			96 T
600	23.6220	23.6200	23.6255	23.6237					23.6268	23.6251			23.6279	23.6251			23.6298	23.6281			61 T
630	24.8031	24.8011	24.8066	24.8048					24.8079	24.8062			24.8090	24.8062			24.8109	24.8092			98 T
670	26.3780	26.3750	26.3819	26.3800					26.3834	26.3815			26.3846	26.3814			26.3869	26.3849			69 T
710	27.9528	27.9498	27.9567	27.9548					27.9582	27.9563			27.9594	27.9562			27.9617	27.9597			119 T
750	29.5276	29.5246	29.5315	29.5296					29.5330	29.5311			29.5342	29.5310			29.5369	29.5349			73 T
800	31.4961	31.4931	31.5000	31.4981					31.5015	31.4996			31.5027	31.4995			31.5054	31.5034			123 T
850	33.4646	33.4607	33.4690	33.4668					33.4707	33.4685			33.4721	33.4685			33.4751	33.4729			83 T
900	35.4331	35.4292	35.4375	35.4353					35.4392	35.4370			35.4406	35.4370			35.4436	35.4414			144 T
950	37.4016	37.3977	37.4060	37.4038					37.4077	37.4055			37.4091	37.4055			37.4125	37.4103			87 T
1000	39.3701	39.3662	39.3745	39.3723					39.3762	39.3740			39.3776	39.3740			39.3810	39.3788			148 T
1060	41.7323	41.7274	41.7375	41.7349					41.7396	41.7370			41.7412	41.7370			41.7447	41.7421			98 T
1120	44.0945	44.0896	44.0997	44.0971					44.1018	44.0992			44.1034	44.0992			44.1069	44.1043			173 T
1180	46.4567	46.4518	46.4619	46.4593					46.4640	46.4614			46.4656	46.4614			46.4695	46.4669			102 T
1250	49.2126	49.2077	49.2178	49.2152					49.2199	49.2173			49.2215	49.2173			49.2254	49.2226			177 T

⁽¹⁾ Resultant fit in 0.0001 in. L indicates a clearance (loose) fit, T indicates an interference (tight) fit.

Shaft tolerances and resultant fits (inch)

Bearing bore diameter d	Resultant fits		Tolerance classes		Fit ¹⁾		s _{6 min} ± IT6/2		Fit ¹⁾		s _{7 min} ± IT7/2		Fit ¹⁾	
	max	min	Shaft diameter max	min	Shaft diameter max	min	Shaft diameter max	min	Shaft diameter max	min	Shaft diameter max	min	Shaft diameter max	min
mm	in.		in.		–	in.		–	in.		–	in.		–
200	7.8740	7.8728	–	–	–	7.8797	7.8785	45 T	7.8800	7.8782	42 T			
220	8.6614	8.6602	8.6664	8.6645	31T/62T	8.6671	8.6659	69 T	8.6674	8.6656	72 T			
240	9.4488	9.4476	9.4539	9.4521	33 T	9.4549	9.4537	49 T/73 T	9.4552	9.4534	46 T/76 T			
260	10.2362	10.2348	10.2419	10.2399	37 T	10.2431	10.2418	56 T	10.2435	10.2414	52 T			
280	11.0236	11.0222	11.0293	11.0273	71 T	11.0305	11.0292	83 T	11.0309	11.0288	87 T			
300	11.8110	11.8096	11.8169	11.8149	39 T/73 T	11.8183	11.8171	61 T/87 T	11.8187	11.8167	57 T/91 T			
320	12.5984	12.5968	12.6049	12.6027	43 T	12.6066	12.6052	68 T	12.6070	12.6048	64 T			
340	13.3858	13.3842	13.3923	13.3901	81 T	13.3940	13.3926	98 T	13.3944	13.3922	102 T			
360	14.1732	14.1716	14.1799	14.1777		14.1821	14.1807		14.1825	14.1803				
380	14.9606	14.9590	14.9673	14.9651	45 T	14.9695	14.9681	75 T	14.9699	14.9677	71 T			
400	15.7480	15.7464	15.7547	15.7525	83 T	15.7569	15.7555	105 T	15.7573	15.7551	109 T			
420	16.5354	16.5336	16.5428	16.5404	50 T	16.5454	16.5438	84 T	16.5458	16.5433	79 T			
440	17.3228	17.3210	17.3302	17.3278	92 T	17.3328	17.3312	118 T	17.3332	17.3307	122 T			
460	18.1102	18.1084	18.1179	18.1154		18.1209	18.1194		18.1214	18.1189				
480	18.8976	18.8958	18.9053	18.9028	52 T	18.9083	18.9068	92 T	18.9088	18.9063	87 T			
500	19.6850	19.6832	19.6927	19.6902	95 T	19.6957	19.6942	125 T	19.6962	19.6937	130 T			
530	20.8661	20.8641	20.8748	20.8720	59 T	20.8780	20.8763	102 T	20.8785	20.8758	97 T			
560	22.0472	22.0452	22.0559	22.0531	107 T	22.0591	22.0574	139 T	22.0596	22.0569	144 T			
600	23.6220	23.6200	23.6309	23.6281	61 T	23.6351	23.6334	114 T	23.6356	23.6329	109 T			
630	24.8031	24.8011	24.8120	24.8092	109 T	24.8162	24.8145	151 T	24.8167	24.8140	156 T			
670	26.3780	26.3750	26.3880	26.3848	68 T	26.3923	26.3904	124 T	26.3929	26.3898	118 T			
710	27.9528	27.9498	27.9628	27.9596	130 T	27.9671	27.9652	173 T	27.9677	27.9646	179 T			
750	29.5276	29.5246	29.5380	29.5349	73 T	29.5435	29.5415	139 T	29.5441	29.5409	133 T			
800	31.4961	31.4931	31.5065	31.5034	134 T	31.5120	31.5100	189 T	31.5126	31.5094	195 T			
850	33.4646	33.4607	33.4764	33.4729	83 T	33.4826	33.4804	158 T	33.4833	33.4797	151 T			
900	35.4331	35.4292	35.4449	35.4414	157 T	35.4511	35.4489	219 T	35.4518	35.4482	226 T			
950	37.4016	37.3977	37.4138	37.4103	87 T	37.4212	37.4190	174 T	37.4219	37.4183	167 T			
1000	39.3701	39.3662	39.3823	39.3788	161 T	39.3897	39.3875	235 T	39.3904	39.3868	242 T			
1060	41.7323	41.7274	41.7463	41.7421	98 T	41.7541	41.7515	192 T	41.7548	41.7507	184 T			
1120	44.0945	44.0896	44.1085	44.1043	189 T	44.1163	44.1137	267 T	44.1170	44.1129	274 T			
1180	46.4567	46.4518	46.4711	46.4669	102 T	46.4808	46.4782	215 T	46.4816	46.4774	207 T			
1250	49.2126	49.2077	49.2270	49.2228	193 T	49.2367	49.2341	290 T	49.2375	49.2333	298 T			

¹⁾ Resultant fit in 0.0001 in. L indicates a clearance (loose) fit, T indicates an interference (tight) fit.

Housing tolerances and resultant fits (inch)

Bearing outside diameter D	Bearing outside diameter		Resultant fits Tolerance classes		G7		H6		H7		Fit ¹⁾			
	max	min	Housing bore		max	min	max	min	max	min	max	min		
	in.	in.	in.	in.	in.	in.	in.	in.	in.	in.	in.	in.		
16	0.6299	0.6296	0.6305	0.6312	16 L 6 L	0.6301	0.6308	12 L 2 L	0.6299	0.6303	7 L 0 L	0.6299	0.6306	10 L 0 L
19	0.7480	0.7476	0.7488	0.7496		0.7483	0.7491		0.7480	0.7485		0.7480	0.7488	
22	0.8661	0.8657	0.8669	0.8677		0.8664	0.8672		0.8661	0.8666		0.8661	0.8669	
24	0.9449	0.9445	0.9457	0.9465	20 L	0.9452	0.9460	15 L	0.9449	0.9454	9 L	0.9449	0.9457	12 L
26	1.0236	1.0232	1.0244	1.0252	8 L	1.0239	1.0247	3 L	1.0236	1.0241	0 L	1.0236	1.0244	0 L
28	1.1024	1.1020	1.1032	1.1040		1.1027	1.1035		1.1024	1.1029		1.1024	1.1032	
30	1.1811	1.1807	1.1819	1.1827		1.1814	1.1822		1.1811	1.1816		1.1811	1.1819	
32	1.2598	1.2594	1.2608	1.2618		1.2602	1.2611		1.2598	1.2604		1.2598	1.2608	
35	1.3780	1.3776	1.3790	1.4000		1.3784	1.3793		1.3780	1.3786		1.3780	1.3790	
37	1.4567	1.4563	1.4577	1.4587	24 L	1.4571	1.4580	17 L	1.4567	1.4573	10 L	1.4567	1.4577	14 L
40	1.5748	1.5744	1.5758	1.5768	10 L	1.5752	1.5761	4 L	1.5748	1.5754	0 L	1.5748	1.5758	0 L
42	1.6535	1.6531	1.6545	1.6555		1.6539	1.6548		1.6535	1.6541		1.6535	1.6545	
47	1.8504	1.8500	1.8514	1.8524		1.8508	1.8517		1.8504	1.8510		1.8504	1.8514	
52	2.0472	2.0467	2.0484	2.0496		2.0476	2.0488		2.0472	2.0479		2.0472	2.0484	
55	2.1654	2.1649	2.1666	2.1678		2.1658	2.1670		2.1654	2.1661		2.1654	2.1666	
62	2.4409	2.4404	2.4421	2.4433		2.4413	2.4425		2.4409	2.4416		2.4409	2.4421	
68	2.6772	2.6767	2.6784	2.6796	29 L	2.6776	2.6788	21 L	2.6772	2.6779	12 L	2.6772	2.6784	17 L
72	2.8346	2.8341	2.8358	2.8370	12 L	2.8350	2.8362	4 L	2.8346	2.8353	0 L	2.8346	2.8358	0 L
75	2.9527	2.9522	2.9539	2.9551		2.9532	2.9543		2.9527	2.9534		2.9527	2.9539	
80	3.1496	3.1491	3.1508	3.1520		3.1500	3.1512		3.1496	3.1503		3.1496	3.1508	
85	3.3465	3.3459	3.3479	3.3493		3.3470	3.3484		3.3465	3.3474		3.3465	3.3479	
90	3.5433	3.5427	3.5447	3.5461		3.5438	3.5452		3.5433	3.5442		3.5433	3.5447	
95	3.7402	3.7396	3.7416	3.7430		3.7407	3.7421		3.7402	3.7411		3.7402	3.7416	
100	3.9370	3.9364	3.9384	3.9398	34 L	3.9375	3.9389	25 L	3.9370	3.9379	15 L	3.9370	3.9384	20 L
110	4.3307	4.3301	4.3321	4.3335	14 L	4.3312	4.3326	5 L	4.3307	4.3316	0 L	4.3307	4.3321	0 L
115	4.5276	4.5270	4.5290	4.5304		4.5281	4.5295		4.5276	4.5285		4.5276	4.5290	
120	4.7244	4.7238	4.7258	4.7272		4.7249	4.7263		4.7244	4.7253		4.7244	4.7258	
125	4.9213	4.9206	4.9230	4.9246		4.9219	4.9234		4.9213	4.9223		4.9213	4.9229	
130	5.1181	5.1174	5.1198	5.1214		5.1187	5.1202		5.1181	5.1191		5.1181	5.1197	
140	5.5118	5.5111	5.5135	5.5151	40 L	5.5124	5.5139	28 L	5.5118	5.5128	17 L	5.5118	5.5134	23 L
145	5.7087	5.7080	5.7104	5.7120	17 L	5.7093	5.7108	6 L	5.7087	5.7097	0 L	5.7087	5.7103	0 L
150	5.9055	5.9048	5.9072	5.9088		5.9061	5.9076		5.9055	5.9065		5.9055	5.9071	
160	6.2992	6.2982	6.3009	6.3025		6.2998	6.3013		6.2992	6.3002		6.2992	6.3008	
165	6.4961	6.4951	6.4978	6.4994	43 L	6.4967	6.4982	31 L	6.4961	6.4971	20 L	6.4961	6.4977	26 L
170	6.6929	6.6919	6.6946	6.6962	17 L	6.6935	6.6950	6 L	6.6929	6.6939	0 L	6.6929	6.6945	0 L
180	7.0866	7.0856	7.0883	7.0899		7.0872	7.0887		7.0866	7.0876		7.0866	7.0882	
190	7.4803	7.4791	7.4823	7.4841		7.4809	7.4827		7.4803	7.4814		7.4803	7.4821	
200	7.8740	7.8728	7.8760	7.8778		7.8746	7.8764		7.8740	7.8751		7.8740	7.8758	
210	8.2677	8.2665	8.2697	8.2715		8.2683	8.2701		8.2677	8.2688		8.2677	8.2695	
215	8.4646	8.4634	8.4666	8.4684		8.4652	8.4670		8.4646	8.4657		8.4646	8.4664	
220	8.6614	8.6602	8.6634	8.6652		8.6620	8.6638		8.6614	8.6625		8.6614	8.6632	
225	8.8583	8.8571	8.8603	8.8621	50 L	8.8589	8.8607	36 L	8.8583	8.8594	23 L	8.8583	8.8601	30 L
230	9.0551	9.0539	9.0571	9.0589	20 L	9.0557	9.0575	6 L	9.0551	9.0562	0 L	9.0551	9.0569	0 L
240	9.4488	9.4476	9.4508	9.4526		9.4494	9.4512		9.4488	9.4499		9.4488	9.4506	
250	9.8425	9.8413	9.8445	9.8463		9.8431	9.8449		9.8425	9.8436		9.8425	9.8443	

¹⁾ Resultant fit in 0.0001 in. L indicates a clearance (loose) fit, T indicates an interference (tight) fit.

Housing tolerances and resultant fits (inch)

Bearing outside diameter D	max		min		Resultant fits		Tolerance classes		G7		H6		H7			
					Housing bore		Fit ¹⁾		Housing bore		Fit ¹⁾		Housing bore		Fit ¹⁾	
	mm	in.	mm	in.	mm	in.	mm	in.	mm	in.	mm	in.	mm	in.		
260	10.2362	10.2348	10.2384	10.2405			10.2369	10.2389			10.2362	10.2375			10.2362	10.2382
270	10.6299	10.6285	10.6321	10.6342			10.6306	10.6326			10.6299	10.6312			10.6299	10.6319
280	11.0236	11.0222	11.0258	11.0279	57 L		11.0243	11.0263	41 L		11.0236	11.0249	27 L		11.0236	11.0256
290	11.4173	11.4159	11.4195	11.4216	22 L		11.4180	11.4200	7 L		11.4173	11.4186	0 L		11.4173	11.4193
300	11.8110	11.8096	11.8132	11.8153			11.8117	11.8137			11.8110	11.8123			11.8110	11.8130
310	12.2047	12.2033	12.2069	12.2090			12.2054	12.2074			12.2047	12.2060			12.2047	12.2067
320	12.5984	12.5968	12.6008	12.6031			12.5991	12.6014			12.5984	12.5998			12.5984	12.6006
340	13.3858	13.3842	13.3882	13.3905			13.3865	13.3888			13.3858	13.3872			13.3858	13.3880
360	14.1732	14.1716	14.1756	14.1779	63 L		14.1739	14.1762	46 L		14.1732	14.1746	30 L		14.1732	14.1754
370	14.5669	14.5654	14.5694	14.5717	24 L		14.5677	14.5700	7 L		14.5669	14.5684	0 L		14.5670	14.5692
380	14.9606	14.9590	14.9630	14.9653			14.9613	14.9636			14.9606	14.9620			14.9606	14.9628
400	15.7480	15.7464	15.7504	15.7527			15.7487	15.7510			15.7480	15.7494			15.7480	15.7502
420	16.5354	16.5336	16.5381	16.5406			16.5362	16.5387			16.5354	16.5370			16.5354	16.5379
440	17.3228	17.3210	17.3255	17.3280	70 L		17.3236	17.3261	51 L		17.3228	17.3244	34 L		17.3228	17.3253
460	18.1102	18.1084	18.1129	18.1154	27 L		18.1110	18.1135	8 L		18.1102	18.1118	0 L		18.1102	18.1127
480	18.8976	18.8958	18.9003	18.9028			18.8984	18.9009			18.8976	18.8992			18.8976	18.9001
500	19.6850	19.6832	19.6877	19.6902			19.6858	19.6883			19.6850	19.6866			19.6850	19.6875
520	20.4724	20.4704	20.4754	20.4781			20.4733	20.4760			20.4724	20.4741			20.4724	20.4752
540	21.2598	21.2578	21.2628	21.2655			21.2607	21.2634			21.2598	21.2615			21.2598	21.2626
560	22.0472	22.0452	22.0502	22.0529	77 L		22.0481	22.0508	56 L		22.0472	22.0489	37 L		22.0472	22.0500
580	22.8346	22.8326	22.8376	22.8403	30 L		22.8355	22.8382	9 L		22.8346	22.8363	0 L		22.8346	22.8374
600	23.6220	23.6200	23.6250	23.6277			23.6229	23.6256			23.6220	23.6237			23.6220	23.6248
620	24.4094	24.4074	24.4124	24.4151			24.4103	24.4130			24.4094	24.4111			24.4094	24.4122
650	25.5906	25.5876	25.5937	25.5969			25.5915	25.5947			25.5906	25.5926			25.5906	25.5937
670	26.3780	26.3750	26.3811	26.3843			26.3789	26.3821			26.3780	26.3800			26.3780	26.3811
680	26.7717	26.7687	26.7748	26.7780			26.7726	26.7758			26.7717	26.7737			26.7717	26.7748
700	27.5591	27.5561	27.5622	27.5654			27.5600	27.5632			27.5591	27.5611			27.5591	27.5622
720	28.3465	28.3435	28.3496	28.3528	93 L		28.3474	28.3506	71 L		28.3465	28.3485	50 L		28.3465	28.3496
750	29.5276	29.5246	29.5307	29.5339	31 L		29.5285	29.5317	9 L		29.5276	29.5296	0 L		29.5276	29.5307
760	29.9213	29.9183	29.9244	29.9276			29.9222	29.9254			29.9213	29.9233			29.9213	29.9244
780	30.7087	30.7057	30.7118	30.7150			30.7096	30.7128			30.7087	30.7107			30.7087	30.7118
790	31.1024	31.0994	31.1055	31.1087			31.1033	31.1065			31.1024	31.1044			31.1024	31.1055
800	31.4961	31.4931	31.4992	31.5024			31.4970	31.5002			31.4961	31.4981			31.4961	31.4992
820	32.2835	32.2796	32.2869	32.2904			32.2845	32.2881			32.2835	32.2857			32.2835	32.2870
830	32.6772	32.6733	32.6806	32.6841			32.6782	32.6818			32.6772	32.6794			32.6772	32.6807
850	33.4646	33.4607	33.4680	33.4715			33.4656	33.4692			33.4646	33.4668			33.4646	33.4681
870	34.2520	34.2481	34.2554	34.2589	108 L		34.2530	34.2566	85 L		34.2520	34.2542	61 L		34.2520	34.2555
920	36.2205	36.2166	36.2239	36.2274	34 L		36.2215	36.2251	10 L		36.2205	36.2227	0 L		36.2205	36.2240
950	37.4016	37.3977	37.4050	37.4085			37.4026	37.4062			37.4016	37.4038			37.4016	37.4051
980	38.5827	38.5788	38.5861	38.5896			38.5837	38.5873			38.5827	38.5849			38.5827	38.5862
1000	39.3701	39.3662	39.3735	39.3770			39.3711	39.3747			39.3701	39.3723			39.3701	39.3736
1150	45.2756	45.2707	45.2795	45.2836	129 L		45.2767	45.2808	101 L		45.2756	45.2782	75 L		45.2756	45.2797
1250	49.2126	49.2077	49.2165	49.2206	39 L		49.2137	49.2178	11 L		49.2126	49.2152	0 L		49.2126	49.2167
1400	55.1181	55.1118	55.1224	55.1274	156 L		55.1193	55.1242	124 L		55.1181	55.1212	94 L		55.1181	55.1230
1600	62.9921	62.9858	62.9964	63.0014	43 L		62.9933	62.9982	12 L		62.9921	62.9952	0 L		62.9921	62.9970

¹⁾ Resultant fit in 0.0001 in. L indicates a clearance (loose) fit, T indicates an interference (tight) fit.

Housing tolerances and resultant fits (inch)

Bearing outside diameter D	Bearing outside diameter		Resultant fits		Tolerance classes		H8 Housing bore max	Fit ¹⁾	H9		Fit ¹⁾	H10		Fit ¹⁾	J6		Fit ¹⁾
	max	min	H8 Housing bore max	min	Housing bore max	min			Housing bore max	min		Housing bore max	min		Housing bore max	min	
mm	in.		in.		-		in.		-		in.		-		in.		-
16	0.6299	0.6296	0.6299	0.6310	14 L OL		0.6299	0.6316	20 L OL		0.6299	0.6327	31 L OL		0.6297	0.6301	5 L 2T
19	0.7480	0.7476	0.7480	0.7493			0.7480	0.7500			0.7480	0.7513			0.7478	0.7483	
22	0.8661	0.8657	0.8661	0.8674			0.8661	0.8681			0.8661	0.8694			0.8659	0.8664	
24	0.9449	0.9445	0.9449	0.9462	17 L OL		0.9449	0.9469	24 L OL		0.9449	0.9482	37 L OL		0.9447	0.9452	7 L 2T
26	1.0236	1.0232	1.0236	1.0249			1.0236	1.0256			1.0236	1.0269			1.0234	1.0239	
28	1.1024	1.1020	1.1024	1.1037			1.1024	1.1044			1.1024	1.1057			1.1022	1.1027	
30	1.1811	1.1807	1.1811	1.1824			1.1811	1.1831			1.1811	1.1844			1.1809	1.1814	
32	1.2598	1.2594	1.2598	1.2613			1.2598	1.2622			1.2598	1.2637			1.2596	1.2602	
35	1.3780	1.3776	1.3780	1.3795			1.3780	1.3804			1.3780	1.3819			1.3778	1.3784	
37	1.4567	1.4563	1.4567	1.4582	19 L OL		1.4567	1.4591	28 L OL		1.4567	1.4606	43 L OL		1.4565	1.4571	8 L 2T
40	1.5748	1.5744	1.5748	1.5763			1.5748	1.5772			1.5748	1.5787			1.5746	1.5752	2T
42	1.6535	1.6531	1.6535	1.6550			1.6535	1.6559			1.6535	1.6574			1.6533	1.6539	
47	1.8504	1.8500	1.8504	1.8519			1.8504	1.8528			1.8504	1.8543			1.8502	1.8508	
52	2.0472	2.0467	2.0472	2.0490			2.0472	2.0501			2.0472	2.0519			2.0470	2.0477	
55	2.1654	2.1649	2.1654	2.1672			2.1654	2.1683			2.1654	2.1701			2.1652	2.1659	
62	2.4409	2.4404	2.4409	2.4427			2.4409	2.4438			2.4409	2.4456			2.4407	2.4414	
68	2.6772	2.6767	2.6772	2.6790	23 L OL		2.6772	2.6801	34 L OL		2.6772	2.6819	52 L OL		2.6770	2.6777	10 L 2T
72	2.8346	2.8341	2.8346	2.8364			2.8346	2.8375			2.8346	2.8393			2.8344	2.8351	
75	2.9527	2.9522	2.9527	2.9545			2.9527	2.9556			2.9527	2.9574			2.9525	2.9532	
80	3.1496	3.1491	3.1496	3.1514			3.1496	3.1525			3.1496	3.1543			3.1494	3.1501	
85	3.3465	3.3459	3.3465	3.3486			3.3465	3.3499			3.3465	3.3520			3.3463	3.3471	
90	3.5433	3.5427	3.5433	3.5454			3.5433	3.5467			3.5433	3.5488			3.5431	3.5439	
95	3.7402	3.7396	3.7402	3.7423	27 L OL		3.7402	3.7436	40 L OL		3.7402	3.7457	61 L OL		3.7400	3.7408	12 L 2T
100	3.9370	3.9364	3.9370	3.9391			3.9370	3.9404			3.9370	3.9425			3.9368	3.9376	
110	4.3307	4.3301	4.3307	4.3328			4.3307	4.3341			4.3307	4.3362			4.3305	4.3313	
115	4.5276	4.5270	4.5276	4.5297			4.5276	4.5310			4.5276	4.5331			4.5274	4.5282	
120	4.7244	4.7238	4.7244	4.7265			4.7244	4.7278			4.7244	4.7299			4.7242	4.7250	
125	4.9213	4.9206	4.9213	4.9238			4.9213	4.9252			4.9213	4.9276			4.9210	4.9220	
130	5.1181	5.1174	5.1181	5.1206			5.1181	5.1220			5.1181	5.1244			5.1178	5.1188	
140	5.5118	5.5111	5.5118	5.5143	32 L OL		5.5118	5.5157	46 L OL		5.5118	5.5181	70 L OL		5.5115	5.5125	14 L 3T
145	5.7087	5.7080	5.7087	5.7112			5.7087	5.7126			5.7087	5.7150			5.7084	5.7094	
150	5.9055	5.9048	5.9055	5.9080			5.9055	5.9094			5.9055	5.9118			5.9052	5.9062	
160	6.2992	6.2982	6.2992	6.3017			6.2992	6.3031			6.2992	6.3055			6.2989	6.2999	
165	6.4961	6.4951	6.4961	6.4986	35 L OL		6.4961	6.5000	49 L OL		6.4961	6.5024	73 L OL		6.4958	6.4968	17 L 3T
170	6.6929	6.6919	6.6929	6.6954			6.6929	6.6968			6.6929	6.6992			6.6926	6.6936	
180	7.0866	7.0856	7.0866	7.0891			7.0866	7.0905			7.0866	7.0929			7.0863	7.0873	
190	7.4803	7.4791	7.4803	7.4831			7.4803	7.4848			7.4803	7.4876			7.4800	7.4812	
200	7.8740	7.8728	7.8740	7.8768			7.8740	7.8785			7.8740	7.8813			7.8737	7.8749	
210	8.2677	8.2665	8.2677	8.2705			8.2677	8.2722			8.2677	8.2750			8.2674	8.2686	
215	8.4646	8.4634	8.4646	8.4674			8.4646	8.4691			8.4646	8.4719			8.4643	8.4655	
220	8.6614	8.6602	8.6614	8.6642	40 L OL		8.6614	8.6659	57 L OL		8.6614	8.6687	85 L OL		8.6611	8.6623	21 L 3T
225	8.8583	8.8571	8.8583	8.8611			8.8583	8.8628			8.8583	8.8656			8.8580	8.8592	
230	9.0551	9.0539	9.0551	9.0579			9.0551	9.0596			9.0551	9.0624			9.0548	9.0560	
240	9.4488	9.4476	9.4488	9.4516			9.4488	9.4533			9.4488	9.4561			9.4485	9.4497	
250	9.8425	9.8413	9.8425	9.8453			9.8425	9.8470			9.8425	9.8498			9.8422	9.8434	

¹⁾ Resultant fit in 0.0001 in. L indicates a clearance (loose) fit, T indicates an interference (tight) fit.

Housing tolerances and resultant fits (inch)

Bearing outside diameter D	max		min		Resultant fits		Tolerance classes		H8		H9		H10		J6		Housing bore	
					Housing bore	min	Fit ¹⁾	Housing bore	min	Fit ¹⁾	Housing bore	min	Fit ¹⁾	Housing bore	min	Fit ¹⁾		
mm	in.					in.						in.						
260	10.2362	10.2348	10.2362	10.2394		10.2362	10.2413		10.2362	10.2445		10.2362	10.2445		10.2359	10.2372		
270	10.6299	10.6285	10.6299	10.6331		10.6299	10.6350		10.6299	10.6382		10.6299	10.6382		10.6296	10.6309		
280	11.0236	11.0222	11.0236	11.0268	46 L	11.0236	11.0287	65 L	11.0236	11.0319	97 L	11.0236	11.0319		11.0233	11.0246	24 L	
290	11.4173	11.4159	11.4173	11.4205	0 L	11.4173	11.4224	0 L	11.4173	11.4256	0 L	11.4173	11.4256		11.4170	11.4183	3 T	
300	11.8110	11.8096	11.8110	11.8142		11.8110	11.8161		11.8110	11.8193		11.8110	11.8193		11.8107	11.8120		
310	12.2047	12.2033	12.2047	12.2079		12.2047	12.2098		12.2047	12.2130		12.2047	12.2130		12.2044	12.2057		
320	12.5984	12.5968	12.5984	12.6019		12.5984	12.6039		12.5984	12.6075		12.5984	12.6075		12.5981	12.5995		
340	13.3858	13.3842	13.3858	13.3893		13.3858	13.3913		13.3858	13.3949		13.3858	13.3949		13.3855	13.3869		
360	14.1732	14.1716	14.1732	14.1767	51 L	14.1732	14.1787	71 L	14.1732	14.1823	107 L	14.1732	14.1823		14.1729	14.1743	27 L	
370	14.5669	14.5654	14.5670	14.5705	0 L	14.5669	14.5724	0 L	14.5669	14.5761	0 L	14.5669	14.5761		14.5666	14.5681	3 T	
380	14.9606	14.9590	14.9606	14.9641		14.9606	14.9661		14.9606	14.9697		14.9606	14.9697		14.9603	14.9617		
400	15.7480	15.7464	15.7480	15.7515		15.7480	15.7535		15.7480	15.7571		15.7480	15.7571		15.7477	15.7491		
420	16.5354	16.5336	16.5354	16.5392		16.5354	16.5415		16.5354	16.5452		16.5354	16.5452		16.5351	16.5367		
440	17.3228	17.3210	17.3228	17.3266		17.3228	17.3289		17.3228	17.3326		17.3228	17.3326		17.3225	17.3241		
460	18.1102	18.1084	18.1102	18.1140		18.1102	18.1163		18.1102	18.1200		18.1102	18.1200		18.1099	18.1115		
480	18.8976	18.8958	18.8976	18.9014	56 L	18.8976	18.9037	79 L	18.8976	18.9074	116 L	18.8976	18.9074		18.8973	18.8989	31 L	
500	19.6850	19.6832	19.6850	19.6888	0 L	19.6850	19.6911	0 L	19.6850	19.6948	0 L	19.6850	19.6948		19.6847	19.6863	3 T	
520	20.4724	20.4704	20.4724	20.4767		20.4724	20.4793		20.4724	20.4834		20.4724	20.4834		20.4721	20.4739		
540	21.2598	21.2578	21.2598	21.2641		21.2598	21.2667		21.2598	21.2708		21.2598	21.2708		21.2595	21.2613		
560	22.0472	22.0452	22.0472	22.0515	63 L	22.0472	22.0541	89 L	22.0472	22.0582	130 L	22.0472	22.0582		22.0469	22.0487	35 L	
580	22.8346	22.8326	22.8346	22.8389	0 L	22.8346	22.8415	0 L	22.8346	22.8456	0 L	22.8346	22.8456		22.8343	22.8361	3 T	
600	23.6220	23.6200	23.6220	23.6263		23.6220	23.6289		23.6220	23.6330		23.6220	23.6330		23.6217	23.6235		
620	24.4094	24.4074	24.4094	24.4137		24.4094	24.4163		24.4094	24.4204		24.4094	24.4204		24.4091	24.4109		
650	25.5906	25.5876	25.5906	25.5955		25.5906	25.5985		25.5906	25.6032		25.5906	25.6032		25.5902	25.5922		
670	26.3780	26.3750	26.3780	26.3829		26.3780	26.3859		26.3780	26.3906		26.3780	26.3906		26.3776	26.3796		
680	26.7717	26.7687	26.7717	26.7766		26.7717	26.7796		26.7717	26.7843		26.7717	26.7843		26.7713	26.7733		
700	27.5591	27.5561	27.5591	27.5640		27.5591	27.5670		27.5591	27.5717		27.5591	27.5717		27.5587	27.5607		
720	28.3465	28.3435	28.3465	28.3514	79 L	28.3465	28.3544	109 L	28.3465	28.3591	156 L	28.3465	28.3591		28.3461	28.3481	46 L	
750	29.5276	29.5246	29.5276	29.5325	0 L	29.5276	29.5355	0 L	29.5276	29.5402	0 L	29.5276	29.5402		29.5272	29.5292	4 T	
760	29.9213	29.9183	29.9213	29.9262		29.9213	29.9292		29.9213	29.9339		29.9213	29.9339		29.9209	29.9229		
780	30.7087	30.7057	30.7087	30.7136		30.7087	30.7166		30.7087	30.7213		30.7087	30.7213		30.7083	30.7103		
790	31.1024	31.0994	31.1024	31.1073		31.1024	31.1103		31.1024	31.1150		31.1024	31.1150		31.1020	31.1040		
800	31.4961	31.4931	31.4961	31.5010		31.4961	31.5040		31.4961	31.5087		31.4961	31.5087		31.4957	31.4968		
820	32.2835	32.2796	32.2835	32.2890		32.2835	32.2926		32.2835	32.2977		32.2835	32.2977		32.2831	32.2853		
830	32.6772	32.6733	32.6772	32.6827		32.6772	32.6863		32.6772	32.6914		32.6772	32.6914		32.6768	32.6790		
850	33.4646	33.4607	33.4646	33.4701		33.4646	33.4737		33.4646	33.4788		33.4646	33.4788		33.4642	33.4664		
870	34.2520	34.2481	34.2520	34.2575	94 L	34.2520	34.2611	130 L	34.2520	34.2662	181 L	34.2520	34.2662		34.2516	34.2538	57 L	
920	36.2205	36.2166	36.2205	36.2260	0 L	36.2205	36.2296	0 L	36.2205	36.2347	0 L	36.2205	36.2347		36.2201	36.2223	4 T	
950	37.4016	37.3977	37.4016	37.4071		37.4016	37.4107		37.4016	37.4158		37.4016	37.4158		37.4012	37.4034		
980	38.5827	38.5788	38.5827	38.5882		38.5827	38.5918		38.5827	38.5969		38.5827	38.5969		38.5823	38.5845		
1000	39.3701	39.3662	39.3701	39.3756		39.3701	39.3792		39.3701	39.3843		39.3701	39.3843		-	-		
1150	45.2756	45.2707	45.2756	45.2821	114 L	45.2756	45.2858	151 L	45.2756	45.2921	214 L	45.2756	45.2921		-	-	-	
1250	49.2126	49.2077	49.2126	49.2191	0 L	49.2126	49.2228	0 L	49.2126	49.2291	0 L	49.2126	49.2291		-	-	-	
1400	55.1181	55.1118	55.1181	55.1258	140 L	55.1181	55.1303	185 L	55.1181	55.1378	260 L	55.1181	55.1378		-	-	-	
1600	62.9921	62.9858	62.9921	62.9998	0 L	62.9921	63.0043	0 L	62.9921	63.0118	0 L	62.9921	63.0118		-	-	-	

¹⁾ Resultant fit in 0.0001 in. L indicates a clearance (loose) fit, T indicates an interference (tight) fit.

Housing tolerances and resultant fits (inch)

Bearing outside diameter D	Bearing outside diameter		Resultant fits		Tolerance classes		J5		K5		K6		Fit ¹⁾	
	max	min	Housing bore max	min	Fit ¹⁾	Housing bore max	min	Fit ¹⁾	Housing bore max	min	Fit ¹⁾	Housing bore max	min	Fit ¹⁾
mm	in.		in.		-	in.		-	in.		-	in.		-
16	0.6299	0.6296	0.6296	0.6303	7L 3T	0.6297	0.6301	2T 5L	0.6297	0.6300	4L 2T	0.6295	0.6300	4L 4T
19	0.7480	0.7476	0.7476	0.7485		0.7478	0.7481		0.7477	0.7480		0.7476	0.7481	
22	0.8661	0.8657	0.8657	0.8666		0.8659	0.8662		0.8658	0.8661		0.8657	0.8662	
24	0.9449	0.9445	0.9445	0.9454	9L	0.9447	0.9450	2T	0.9446	0.9449	4L	0.9445	0.9450	5L
26	1.0236	1.0232	1.0232	1.0241	4T	1.0234	1.0237	5L	1.0233	1.0236	3T	1.0232	1.0237	4T
28	1.1024	1.1020	1.1020	1.1029		1.1022	1.1025		1.1021	1.1024		1.1020	1.1025	
30	1.1811	1.1807	1.1807	1.1816		1.1809	1.1812		1.1808	1.1811		1.1807	1.1812	
32	1.2598	1.2594	1.2594	1.2604		1.2596	1.2600		1.2594	1.2599		1.2593	1.2599	
35	1.3780	1.3776	1.3776	1.3786		1.3778	1.3782		1.3776	1.3781		1.3775	1.3781	
37	1.4567	1.4563	1.4563	1.4573	10L	1.4565	1.4569	2T	1.4563	1.4568	5L	1.4562	1.4568	5L
40	1.5748	1.5744	1.5744	1.5754	4T	1.5746	1.5750	6L	1.5744	1.5749	4T	1.5743	1.5749	5T
42	1.6535	1.6531	1.6531	1.6541		1.6533	1.6537		1.6531	1.6536		1.6530	1.6536	
47	1.8504	1.8500	1.8500	1.8510		1.8502	1.8506		1.8500	1.8505		1.8499	1.8505	
52	2.0472	2.0467	2.0467	2.0479		2.0469	2.0475		2.0468	2.0473		2.0466	2.0474	
55	2.1654	2.1649	2.1649	2.1661		2.1651	2.1657		2.1650	2.1655		2.1648	2.1656	
62	2.4409	2.4404	2.4404	2.4416		2.4406	2.4412		2.4405	2.4410		2.4403	2.4411	
68	2.6772	2.6767	2.6767	2.6779	12L 5T	2.6769	2.6775	3T 8L	2.6768	2.6773	6L 4T	2.6766	2.6774	7L 6T
72	2.8346	2.8341	2.8341	2.8353		2.8343	2.8349		2.8342	2.8347		2.8340	2.8348	
75	2.9527	2.9522	2.9522	2.9534		2.9524	2.9530		2.9523	2.9528		2.9521	2.9529	
80	3.1496	3.1491	3.1491	3.1503		3.1493	3.1499		3.1492	3.1497		3.1490	3.1498	
85	3.3465	3.3459	3.3460	3.3474		3.3462	3.3468		3.3460	3.3466		3.3458	3.3467	
90	3.5433	3.5427	3.5428	3.5442		3.5430	3.5436		3.5428	3.5434		3.5426	3.5435	
95	3.7402	3.7396	3.7397	3.7411	15L 5T	3.7399	3.7405	3T	3.7397	3.7403	7L 5T	3.7395	3.7404	8L 7T
100	3.9370	3.9364	3.9365	3.9379		3.9367	3.9373	9L	3.9365	3.9371		3.9363	3.9372	
110	4.3307	4.3301	4.3302	4.3316		4.3304	4.3310		4.3302	4.3308		4.3300	4.3309	
115	4.5276	4.5270	4.5271	4.5285		4.5273	4.5279		4.5271	4.5277		4.5269	4.5278	
120	4.7244	4.7238	4.7239	4.7253		4.7241	4.7247		4.7239	4.7245		4.7237	4.7246	
125	4.9213	4.9206	4.9207	4.9223		4.9209	4.9217		4.9207	4.9214		4.9205	4.9215	
130	5.1181	5.1174	5.1175	5.1191	17L 6T	5.1177	5.1185	4T	5.1175	5.1182	8L 6T	5.1173	5.1183	9L 8T
140	5.5118	5.5111	5.5112	5.5128		5.5114	5.5122	11L	5.5112	5.5119		5.5110	5.5120	
145	5.7087	5.7080	5.7081	5.7097		5.7083	5.7091		5.7081	5.7088		5.7079	5.7089	
150	5.9055	5.9048	5.9049	5.9065		5.9051	5.9059		5.9049	5.9056		5.9047	5.9057	
160	6.2992	6.2982	6.2986	6.3002	20L 6T	6.2988	6.2995	4T	6.2986	6.2993	11L 6T	6.2984	6.2994	12L 8T
165	6.4961	6.4951	6.4955	6.4971		6.4957	6.4964	13L	6.4955	6.4962		6.4953	6.4963	
170	6.6929	6.6919	6.6923	6.6939		6.6925	6.6932		6.6923	6.6930		6.6921	6.6931	
180	7.0866	7.0856	7.0860	7.0876		7.0862	7.0869		7.0860	7.0867		7.0858	7.0868	
190	7.4803	7.4791	7.4797	7.4815		7.4799	7.4807		7.4796	7.4804		7.4794	7.4805	
200	7.8740	7.8728	7.8734	7.8752		7.8736	7.8744		7.8733	7.8741		7.8731	7.8742	
210	8.2677	8.2665	8.2671	8.2689		8.2673	8.2681		8.2670	8.2678		8.2668	8.2679	
215	8.4646	8.4634	8.4640	8.4658		8.4642	8.4650		8.4639	8.4647		8.4637	8.4648	
220	8.6614	8.6602	8.6608	8.6626	24L 6T	8.6610	8.6618	4T	8.6607	8.6615	13L 7T	8.6605	8.6616	14L 9T
225	8.8583	8.8571	8.8577	8.8595		8.8579	8.8587	16L	8.8576	8.8584		8.8574	8.8585	
230	9.0551	9.0539	9.0545	9.0563		9.0547	9.0555		9.0544	9.0552		9.0542	9.0553	
240	9.4488	9.4476	9.4482	9.4500		9.4484	9.4492		9.4481	9.4489		9.4479	9.4490	
250	9.8425	9.8413	9.8419	9.8437		9.8421	9.8429		9.8418	9.8426		9.8416	9.8427	

¹⁾ Resultant fit in 0.0001 in. L indicates a clearance (loose) fit, T indicates an interference (tight) fit.

Housing tolerances and resultant fits (inch)

Bearing outside diameter D	Bearing outside diameter		Resultant fits Tolerance classes		J5 Housing bore max	Fit ¹⁾	J5 Housing bore min	Fit ¹⁾	K5 Housing bore max	K5 Housing bore min	Fit ¹⁾	K6 Housing bore max	K6 Housing bore min	Fit ¹⁾
	max	min	Housing bore max	Housing bore min										
mm	in.		in.		in.	-	in.	-	in.		-	in.		-
260	10.2362	10.2348	10.2356	10.2376			10.2357	10.2366		10.2354	10.2363		10.2351	10.2364
270	10.6299	10.6285	10.6293	10.6313			10.6294	10.6303		10.6291	10.6300		10.6288	10.6301
280	11.0236	11.0222	11.0230	11.0250	28 L		11.0231	11.0240	5 T	11.0228	11.0237	15 L	11.0225	11.0238
290	11.4173	11.4159	11.4167	11.4187	6 T		11.4168	11.4177	18 L	11.4165	11.4174	8 T	11.4162	11.4175
300	11.8110	11.8096	11.8104	11.8124			11.8105	11.8114		11.8102	11.8111		11.8099	11.8112
310	12.2047	12.2033	12.2041	12.2061			12.2042	12.2051		12.2039	12.2048		12.2036	12.2049
320	12.5984	12.5968	12.5977	12.5997			12.5979	12.5989		12.5975	12.5985		12.5973	12.5986
340	13.3858	13.3842	13.3851	13.3873			13.3853	13.3863		13.3849	13.3859		13.3847	13.3860
360	14.1732	14.1716	14.1725	14.1747	31 L		14.1727	14.1737	5 T	14.1723	14.1733	17 L	14.1721	14.1734
370	14.5669	14.5654	14.5662	14.5685	7 T		14.5664	14.5675	21 L	14.5660	14.5670	9 T	14.5658	14.5672
380	14.9606	14.9590	14.9599	14.9621			14.9601	14.9611		14.9597	14.9607		14.9595	14.9608
400	15.7480	15.7464	15.7473	15.7495			15.7475	15.7485		15.7471	15.7481		15.7469	15.7482
420	16.5354	16.5336	16.5346	16.5371			16.5349	16.5359		16.5344	16.5355		16.5341	16.5356
440	17.3228	17.3210	17.3220	17.3245	35 L		17.3223	17.3233	5 T	17.3218	17.3229	19 L	17.3215	17.3230
460	18.1102	18.1084	18.1094	18.1119	8 T		18.1097	18.1107	23 L	18.1092	18.1103	10 T	18.1089	18.1104
480	18.8976	18.8958	18.8968	18.8993			18.8971	18.8981		18.8966	18.8977		18.8963	18.8978
500	19.6850	19.6832	19.6842	19.6867			19.6845	19.6855		19.6840	19.6851		19.6837	19.6852
520	20.4724	20.4704	20.4715	20.4743		-	-	-	-	-	-		20.4707	20.4724
540	21.2598	21.2578	21.2589	21.2617		-	-	-	-	-	-		21.2581	21.2598
560	22.0472	22.0452	22.0463	22.0491	39 L		-	-	-	-	-		22.0455	22.0472
580	22.8346	22.8326	22.8337	22.8365	9 T		-	-	-	-	-		22.8329	22.8346
600	23.6220	23.6200	23.6211	23.6239		-	-	-	-	-	-		23.6203	23.6220
620	24.4094	24.4074	24.4085	24.4113		-	-	-	-	-	-		24.4077	24.4094
650	25.5906	25.5876	25.5897	25.5928		-	-	-	-	-	-		25.5886	25.5906
670	26.3780	26.3750	26.3771	26.3802		-	-	-	-	-	-		26.3760	26.3780
680	26.7717	26.7687	26.7708	26.7739		-	-	-	-	-	-		26.7697	26.7717
700	27.5591	27.5561	27.5582	27.5613		-	-	-	-	-	-		27.5571	27.5591
720	28.3465	28.3435	28.3456	28.3487	52 L		-	-	-	-	-		28.3445	28.3465
750	29.5276	29.5246	29.5267	29.5298	9 T		-	-	-	-	-		29.5256	29.5276
760	29.9213	29.9183	29.9204	29.9235		-	-	-	-	-	-		29.9193	29.9213
780	30.7087	30.7057	30.7078	30.7109		-	-	-	-	-	-		30.7067	30.7087
790	31.1024	31.0994	31.1015	31.1046		-	-	-	-	-	-		31.1004	31.1024
800	31.4961	31.4931	31.4952	31.4974		-	-	-	-	-	-		31.4941	31.4952
820	32.2835	32.2796	32.2825	32.2860		-	-	-	-	-	-		32.2813	32.2835
830	32.6772	32.6733	32.6762	32.6797		-	-	-	-	-	-		32.6750	32.6772
850	33.4646	33.4607	33.4636	33.4671		-	-	-	-	-	-		33.4624	33.4646
870	34.2520	34.2481	34.2510	34.2545	64 L		-	-	-	-	-		34.2498	34.2520
920	36.2205	36.2166	36.2195	36.2230	10 T		-	-	-	-	-		36.2183	36.2205
950	37.4016	37.3977	37.4006	37.4041		-	-	-	-	-	-		37.3994	37.4016
980	38.5827	38.5788	38.5817	38.5852		-	-	-	-	-	-		38.5805	38.5827
1000	39.3701	39.3662	-	-		-	-	-	-	-	-		-	-
1150	45.2756	45.2707	-	-		-	-	-	-	-	-		-	-
1250	49.2126	49.2077	-	-		-	-	-	-	-	-		-	-
1400	55.1181	55.1118	-	-		-	-	-	-	-	-		-	-
1600	62.9921	62.9858	-	-		-	-	-	-	-	-		-	-

¹⁾ Resultant fit in 0.0001 in. L indicates a clearance (loose) fit, T indicates an interference (tight) fit.

Housing tolerances and resultant fits (inch)

Bearing outside diameter D	Bearing outside diameter		Resultant fits Tolerance classes		M5		M6		M7		Fit ¹⁾			
	max	min	Housing bore max	min	Housing bore max	min	Housing bore max	min	Housing bore max	min	Housing bore max	min		
mm	in.		in.		-	in.		-	in.		-	in.		
16	0.6299	0.6296	0.6294	0.6301	5L 5T	0.6294	0.6298	2L 5T	0.6293	0.6297	1L 6T	0.6292	0.6299	3L 7T
19	0.7480	0.7476	0.7474	0.7482		0.7474	0.7478		0.7473	0.7478		0.7472	0.7480	
22	0.8661	0.8657	0.8655	0.8663		0.8655	0.8659		0.8654	0.8659		0.8653	0.8661	
24	0.9449	0.9445	0.9443	0.9451	6L	0.9443	0.9447	2L	0.9442	0.9447	2L	0.9441	0.9449	4L
26	1.0236	1.0232	1.0230	1.0238	6T	1.0230	1.0234	6T	1.0229	1.0234	7T	1.0228	1.0236	8T
28	1.1024	1.1020	1.1018	1.1026		1.1018	1.1022		1.1017	1.1022		1.1016	1.1024	
30	1.1811	1.1807	1.1805	1.1813		1.1805	1.1809		1.1804	1.1809		1.1803	1.1811	
32	1.2598	1.2594	1.2591	1.2601		1.2592	1.2596		1.2590	1.2596		1.2588	1.2598	
35	1.3780	1.3776	1.3773	1.3783		1.3774	1.3778		1.3772	1.3778		1.3770	1.3780	
37	1.4567	1.4563	1.4560	1.4570	7L	1.4561	1.4565	2L	1.4559	1.4565	2L	1.4557	1.4567	4L
40	1.5748	1.5744	1.5741	1.5751	7T	1.5742	1.5746	6T	1.5740	1.5746	8T	1.5738	1.5748	10T
42	1.6535	1.6531	1.6528	1.6538		1.6529	1.6533		1.6527	1.6533		1.6525	1.6535	
47	1.8504	1.8500	1.8497	1.8507		1.8498	1.8502		1.8496	1.8502		1.8494	1.8504	
52	2.0472	2.0467	2.0464	2.0476		2.0465	2.0470		2.0463	2.0470		2.0460	2.0472	
55	2.1654	2.1649	2.1646	2.1658		2.1647	2.1652		2.1645	2.1652		2.1642	2.1654	
62	2.4409	2.4404	2.4401	2.4413		2.4402	2.4407		2.4400	2.4407		2.4397	2.4409	
68	2.6772	2.6767	2.6764	2.6776	9L	2.6765	2.6770	3L	2.6763	2.6770	3L	2.6760	2.6772	5L
72	2.8346	2.8341	2.8338	2.8350	8T	2.8339	2.8344	7T	2.8337	2.8344	3T	2.8334	2.8346	12T
75	2.9527	2.9522	2.9519	2.9531		2.9520	2.9525		2.9518	2.9525		2.9516	2.9527	
80	3.1496	3.1491	3.1488	3.1500		3.1489	3.1494		3.1487	3.1494		3.1484	3.1496	
85	3.3465	3.3459	3.3455	3.3469		3.3456	3.3462		3.3454	3.3463		3.3451	3.3465	
90	3.5433	3.5427	3.5423	3.5437		3.5424	3.5430		3.5422	3.5431		3.5419	3.5433	
95	3.7402	3.7396	3.7392	3.7406		3.7393	3.7399		3.7391	3.7400		3.7388	3.7402	
100	3.9370	3.9364	3.9360	3.9374	10L	3.9361	3.9367	3L	3.9359	3.9368	4L	3.9356	3.9370	6L
110	4.3307	4.3301	4.3297	4.3311	10T	4.3298	4.3304	9T	4.3296	4.3305	11T	4.3293	4.3307	14T
115	4.5276	4.5270	4.5266	4.5280		4.5267	4.5273		4.5265	4.5274		4.5262	4.5276	
120	4.7244	4.7238	4.7234	4.7248		4.7235	4.7241		4.7233	4.7242		4.7230	4.7244	
125	4.9213	4.9206	4.9202	4.9218		4.9202	4.9210		4.9200	4.9210		4.9197	4.9213	
130	5.1181	5.1174	5.1170	5.1186		5.1170	5.1178		5.1168	5.1178		5.1165	5.1181	
140	5.5118	5.5111	5.5107	5.5123	12L	5.5107	5.5115	4L	5.5105	5.5115	4L	5.5102	5.5118	7L
145	5.7087	5.7080	5.7076	5.7092	11T	5.7076	5.7084	11T	5.7074	5.7084	13T	5.7071	5.7087	16T
150	5.9055	5.9048	5.9044	5.9060		5.9044	5.9052		5.9042	5.9052		5.9039	5.9055	
160	6.2992	6.2982	6.2981	6.2997		6.2981	6.2988		6.2979	6.2989		6.2976	6.2992	
165	6.4961	6.4951	6.4950	6.4966	15L	6.4950	6.4957	6L	6.4948	6.4958	7L	6.4945	6.4961	10L
170	6.6929	6.6919	6.6918	6.6934	11T	6.6918	6.6925	11T	6.6916	6.6926	13T	6.6913	6.6929	16T
180	7.0866	7.0856	7.0855	7.0871		7.0855	7.0862		7.0853	7.0863		7.0850	7.0866	
190	7.4803	7.4791	7.4790	7.4808		7.4791	7.4798		7.4788	7.4800		7.4785	7.4803	
200	7.8740	7.8728	7.8727	7.8745		7.8728	7.8735		7.8725	7.8737		7.8722	7.8740	
210	8.2677	8.2665	8.2664	8.2682		8.2665	8.2672		8.2662	8.2674		8.2659	8.2677	
215	8.4646	8.4634	8.4633	8.4651		8.4634	8.4641		8.4631	8.4643		8.4628	8.4646	
220	8.6614	8.6602	8.6601	8.6619	17L	8.6602	8.6609	7L	8.6599	8.6611	9L	8.6596	8.6614	12L
225	8.8583	8.8571	8.8570	8.8588	13T	8.8571	8.8578	12T	8.8568	8.8580	15T	8.8565	8.8583	18T
230	9.0551	9.0539	9.0538	9.0556		9.0539	9.0546		9.0536	9.0548		9.0533	9.0551	
240	9.4488	9.4476	9.4475	9.4493		9.4476	9.4483		9.4473	9.4485		9.4470	9.4488	
250	9.8425	9.8413	9.8412	9.8430		9.8413	9.8420		9.8410	9.8422		9.8407	9.8425	

¹⁾ Resultant fit in 0.0001 in. L indicates a clearance (loose) fit, T indicates an interference (tight) fit.

Housing tolerances and resultant fits (inch)

Bearing outside diameter D	Bearing outside diameter		Resultant fits Tolerance classes		M5 Housing bore max	M5 Housing bore min	M6 Housing bore max	M6 Housing bore min	M7 Housing bore max	M7 Housing bore min	Fit ¹⁾	Fit ¹⁾	Fit ¹⁾	Fit ¹⁾
	max	min	Housing bore max	Housing bore min										
mm	in.		in.		in.		in.		in.					
260	10.2362	10.2348	10.2348	10.2368		10.2348	10.2357	10.2346	10.2364		10.2342	10.2362		
270	10.6299	10.6285	10.6285	10.6305		10.6285	10.6294	10.6283	10.6301		10.6279	10.6299		
280	11.0236	11.0222	11.0222	11.0242	20 L	11.0222	11.0231	11.0220	11.0238	10 L	11.0216	11.0236	14 L	
290	11.4173	11.4159	11.4159	11.4179	14 T	11.4159	11.4168	11.4157	11.4175	16 T	11.4153	11.4173	20 T	
300	11.8110	11.8096	11.8096	11.8116		11.8096	11.8105	11.8094	11.8112		11.8090	11.8110		
310	12.2047	12.2033	12.2033	12.2053		12.2033	12.2042	12.2031	12.2049		12.2027	12.2047		
320	12.5984	12.5968	12.5968	12.5991		12.5969	12.5978	12.5966	12.5986		12.5962	12.5984		
340	13.3858	13.3842	13.3842	13.3865		13.3843	13.3852	13.3840	13.3860		13.3836	13.3858		
360	14.1732	14.1716	14.1716	14.1739	23 L	14.1717	14.1726	14.1714	14.1734	12 L	14.1710	14.1732	16 L	
370	14.5669	14.5654	14.5653	14.5677	16 T	14.5654	14.5664	14.5651	14.5672	15 T	14.5647	14.5669	22 T	
380	14.9606	14.9590	14.9590	14.9613		14.9591	14.9600	14.9588	14.9608		14.9584	14.9606		
400	15.7480	15.7464	15.7464	15.7487		15.7465	15.7474	15.7462	15.7482		15.7458	15.7480		
420	16.5354	16.5336	16.5336	16.5361		16.5337	16.5347	16.5334	16.5356		16.5329	16.5354		
440	17.3228	17.3210	17.3210	17.3235	25 L	17.3211	17.3221	17.3208	17.3230	11 L	17.3203	17.3228	18 L	
460	18.1102	18.1084	18.1084	18.1109	18 T	18.1085	18.1095	18.1082	18.1104	17 T	18.1077	18.1102	25 T	
480	18.8976	18.8958	18.8958	18.8983		18.8959	18.8969	18.8956	18.8978		18.8951	18.8976		
500	19.6850	19.6832	19.6832	19.6857		19.6833	19.6843	19.6830	19.6852		19.6825	19.6850		
520	20.4724	20.4704	20.4696	20.4724		-	-	20.4696	20.4714		20.4686	20.4714		
540	21.2598	21.2578	21.2570	21.2598		-	-	21.2570	21.2588		21.2560	21.2588		
560	22.0472	22.0452	22.0444	22.0472	20 L	-	-	22.0444	22.0462	10 L	22.0435	22.0462	10 L	
580	22.8346	22.8326	22.8318	22.8346	28 T	-	-	22.8318	22.8336	28 T	22.8308	22.8336	38 T	
600	23.6220	23.6200	23.6192	23.6220		-	-	23.6192	23.6210		23.6182	23.6210		
620	24.4094	24.4074	24.4066	24.4094		-	-	24.4066	24.4084		24.4056	24.4084		
650	25.5906	25.5876	25.5875	25.5906		-	-	25.5875	25.5894		25.5863	25.5894		
670	26.3780	26.3750	26.3749	26.3780		-	-	26.3749	26.3768		26.3737	26.3768		
680	26.7717	26.7687	26.7686	26.7717		-	-	26.7686	26.7705		26.7674	26.7705		
700	27.5591	27.5561	27.5560	27.5591		-	-	27.5560	27.5579		27.5548	27.5579		
720	28.3465	28.3435	28.3434	28.3465	30 L	-	-	28.3434	28.3453	18 L	28.3422	28.3453	18 L	
750	29.5276	29.5246	29.5245	29.5276	31 T	-	-	29.5245	29.5264	31 T	29.5233	29.5264	43 T	
760	29.9213	29.9183	29.9182	29.9213		-	-	29.9182	29.9201		29.9169	29.9201		
780	30.7087	30.7057	30.7056	30.7087		-	-	30.7056	30.7075		30.7044	30.7075		
790	31.1024	31.0994	31.0993	31.1024		-	-	31.0993	31.1012		31.0981	31.1012		
800	31.4961	31.4931	31.4930	31.4961		-	-	31.4930	31.4949		31.4917	31.4949		
820	32.2835	32.2796	32.2800	32.2835		-	-	32.2800	32.2822		32.2786	32.2822		
830	32.6772	32.6733	32.6737	32.6772		-	-	32.6737	32.6759		32.6723	32.6758		
850	33.4646	33.4607	33.4611	33.4646		-	-	33.4611	33.4633		33.4597	33.4633		
870	34.2520	34.2481	34.2485	34.2520	39 L	-	-	34.2485	34.2507	26 L	34.2471	34.2507	26 L	
920	36.2205	36.2166	36.2170	36.2205	35 T	-	-	36.2170	36.2192	35 T	36.2156	36.2192	49 T	
950	37.4016	37.3977	37.3981	37.4016		-	-	37.3981	37.4003		37.3967	37.4003		
980	38.5827	38.5788	38.5792	38.5827		-	-	38.5792	38.5814		38.5778	38.5814		
1000	39.3701	39.3662	-	-		-	-	-	-		39.3652	39.3688		
1150	45.2756	45.2707	-	-	-	-	-	-	-	-	45.2699	45.2740	33 L	
1250	49.2126	49.2077	-	-	-	-	-	-	-	-	49.2069	49.2110	57 T	
1400	55.1181	55.1118	-	-	-	-	-	-	-	-	55.1113	55.1162	44 L	
1600	62.9921	62.9858	-	-	-	-	-	-	-	-	62.9853	62.9902	68 T	

¹⁾ Resultant fit in 0.0001 in. L indicates a clearance (loose) fit, T indicates an interference (tight) fit.

Housing tolerances and resultant fits (inch)

Bearing outside diameter D	Bearing outside diameter		Resultant fits		Tolerance classes		N6		N7		P6		P7		Fit ¹⁾		
	max	min	Housing bore max	Housing bore min	Fit ¹⁾	Housing bore max	Housing bore min	Fit ¹⁾	Housing bore max	Housing bore min	Fit ¹⁾	Housing bore max	Housing bore min	Fit ¹⁾	Housing bore max	Housing bore min	Fit ¹⁾
mm	in.		in.		-	in.		-	in.		-	in.		-	in.		-
16	0.6299	0.6296	0.6291	0.6295	1T 8T	0.6290	0.6297	1L 9T	0.6289	0.6293	3T 10T	0.6288	0.6295	1T 11T			
19	0.7480	0.7476	0.7471	0.7476		0.7469	0.7477		0.7468	0.7473		0.7466	0.7474				
22	0.8661	0.8657	0.8652	0.8657		0.8650	0.8658		0.8649	0.8654		0.8647	0.8655				
24	0.9449	0.9445	0.9440	0.9445	0T	0.9438	0.9446	1L	0.9437	0.9442	3T	0.9435	0.9443	2T			
26	1.0236	1.0232	1.0227	1.0232	9T	1.0225	1.0233	11T	1.0224	1.0229	12T	1.0222	1.0230	14T			
28	1.1024	1.1020	1.1015	1.1020		1.1013	1.1021		1.1012	1.1017		1.1010	1.1018				
30	1.1811	1.1807	1.1802	1.1807		1.1800	1.1808		1.1799	1.1804		1.1797	1.1805				
32	1.2598	1.2594	1.2587	1.2593		1.2585	1.2595		1.2583	1.2590		1.2581	1.2591				
35	1.3780	1.3776	1.3769	1.3775		1.3767	1.3777		1.3765	1.3772		1.3763	1.3773				
37	1.4567	1.4563	1.4556	1.4562	1T	1.4554	1.4564	1L	1.4552	1.4559	4T	1.4550	1.4560	3T			
40	1.5748	1.5744	1.5737	1.5743	11T	1.5735	1.5745	13T	1.5733	1.5740	15T	1.5731	1.5741	17T			
42	1.6535	1.6531	1.6524	1.6530		1.6522	1.6532		1.6520	1.6527		1.6518	1.6528				
47	1.8504	1.8500	1.8493	1.8499		1.8491	1.8501		1.8489	1.8496		1.8487	1.8497				
52	2.0472	2.0467	2.0459	2.0466		2.0457	2.0468		2.0454	2.0462		2.0452	2.0464				
55	2.1654	2.1649	2.1641	2.1648		2.1639	2.1650		2.1636	2.1644		2.1634	2.1646				
62	2.4409	2.4404	2.4396	2.4403		2.4394	2.4405		2.4391	2.4399		2.4389	2.4401				
68	2.6772	2.6767	2.6759	2.6766	1T	2.6760	2.6770	1L	2.6750	2.6760	5T	2.6752	2.6763	3T			
72	2.8346	2.8341	2.8333	2.8340	13T	2.8331	2.8342	15T	2.8328	2.8336	18T	2.8326	2.8338	20T			
75	2.9527	2.9522	2.9515	2.9522		2.9510	2.9520		2.9510	2.9520		2.9507	2.9519				
80	3.1496	3.1491	3.1483	3.1490		3.1481	3.1492		3.1478	3.1486		3.1476	3.1488				
85	3.3465	3.3459	3.3450	3.3459		3.3447	3.3461		3.3445	3.3453		3.3442	3.3456				
90	3.5433	3.5427	3.5418	3.5427		3.5415	3.5429		3.5413	3.5421		3.5410	3.5424				
95	3.7402	3.7396	3.7387	3.7396	0T	3.7380	3.7400	2L	3.7380	3.7390	6T	3.7378	3.7392	3T			
100	3.9370	3.9364	3.9355	3.9364	15T	3.9352	3.9366	18T	3.9350	3.9358	20T	3.9347	3.9361	23T			
110	4.3307	4.3301	4.3292	4.3301		4.3289	4.3303		4.3287	4.3295		4.3284	4.3298				
115	4.5276	4.5270	4.5261	4.5270		4.5258	4.5272		4.5256	4.5264		4.5253	4.5267				
120	4.7244	4.7238	4.7229	4.7238		4.7226	4.7240		4.7224	4.7232		4.7221	4.7235				
125	4.9213	4.9206	4.9195	4.9205		4.9193	4.9208		4.9189	4.9199		4.9186	4.9202				
130	5.1181	5.1174	5.1163	5.1173		5.1161	5.1176		5.1157	5.1167		5.1154	5.1170				
140	5.5118	5.5111	5.5100	5.5110	1T	5.5098	5.5113	2L	5.5094	5.5104	7T	5.5091	5.5107	4T			
145	5.7087	5.7080	5.7069	5.7079	18T	5.7067	5.7082	20T	5.7063	5.7073	24T	5.7060	5.7076	27T			
150	5.9055	5.9048	5.9037	5.9047		5.9035	5.9050		5.9031	5.9041		5.9028	5.9044				
160	6.2992	6.2982	6.2974	6.2984		6.2972	6.2987		6.2968	6.2978		6.2965	6.2981				
165	6.4961	6.4951	6.4943	6.4953	2L	6.4940	6.4960	5L	6.4940	6.4950	4T	6.4934	6.4950	1T			
170	6.6929	6.6919	6.6911	6.6921	18T	6.6909	6.6924	20T	6.6905	6.6915	24T	6.6902	6.6918	27T			
180	7.0866	7.0856	7.0848	7.0858		7.0846	7.0861		7.0842	7.0852		7.0839	7.0855				
190	7.4803	7.4791	7.4783	7.4794		7.4779	7.4797		7.4775	7.4787		7.4772	7.4790				
200	7.8740	7.8728	7.8720	7.8731		7.8716	7.8734		7.8712	7.8724		7.8709	7.8727				
210	8.2677	8.2665	8.2657	8.2668		8.2653	8.2671		8.2649	8.2661		8.2646	8.2664				
215	8.4646	8.4634	8.4626	8.4637		8.4622	8.4640		8.4618	8.4630		8.4615	8.4633				
220	8.6614	8.6602	8.6594	8.6606		8.6590	8.6610		8.6590	8.6600		8.6583	8.6601				
225	8.8583	8.8571	8.8563	8.8574	3L	8.8559	8.8577	6L	8.8555	8.8567	4T	8.8552	8.8570	1T			
230	9.0551	9.0539	9.0531	9.0543	20T	9.0530	9.0550	24T	9.0520	9.0540	28T	9.0520	9.0538	31T			
240	9.4488	9.4476	9.4468	9.4479		9.4466	9.4482		9.4460	9.4472		9.4457	9.4475				
250	9.8425	9.8413	9.8405	9.8416		9.8401	9.8419		9.8397	9.8409		9.8394	9.8412				

¹⁾ Resultant fit in 0.0001 in. L indicates a clearance (loose) fit, T indicates an interference (tight) fit.

Housing tolerances and resultant fits (inch)

Bearing outside diameter D	max		min		Resultant fits		Tolerance classes		N6		N7		P6		P7	
					Housing bore max	min	Fit ¹⁾	Housing bore max	min	Fit ¹⁾	Housing bore max	min	Fit ¹⁾	Housing bore max	min	Fit ¹⁾
mm	in.			in.		–	in.		–	in.		–	in.		–	in.
260	10.2362	10.2348	10.2340	10.2352			10.2336	10.2356		10.2331	10.2343		10.2327	10.2348		
270	10.6299	10.6285	10.6277	10.6289			10.6270	10.6290		10.6270	10.6280		10.6265	10.6285		
280	11.0236	11.0222	11.0214	11.0226	4 L		11.0210	11.0230	8 L	11.0205	11.0217	5 T	11.0201	11.0222	0 T	
290	11.4173	11.4159	11.4151	11.4163	22 T		11.4150	11.4170	26 T	11.4140	11.4150	31 T	11.4139	11.4159	35 T	
300	11.8110	11.8096	11.8088	11.8100			11.8084	11.8104		11.8079	11.8091		11.8075	11.8096		
310	12.2047	12.2033	12.2025	12.2037			12.2021	12.2041		12.2016	12.2028		12.2012	12.2033		
320	12.5984	12.5968	12.5960	12.5974			12.5955	12.5978		12.5950	12.5964		12.5945	12.5968		
340	13.3858	13.3842	13.3834	13.3848			13.3829	13.3852		13.3824	13.3838		13.3819	13.3842		
360	14.1732	14.1716	14.1708	14.1722	6 L		14.1703	14.1726	10 L	14.1698	14.1712	4 T	14.1693	14.1716	0 T	
370	14.5669	14.5654	14.5645	14.5659	24 T		14.5640	14.5660	29 T	14.5640	14.5660	34 T	14.5631	14.5653	39 T	
380	14.9606	14.9590	14.9582	14.9596			14.9577	14.9600		14.9572	14.9586		14.9567	14.9590		
400	15.7480	15.7464	15.7456	15.7470			15.7451	15.7474		15.7446	15.7460		15.7441	15.7464		
420	16.5354	16.5336	16.5328	16.5343			16.5323	16.5347		16.5317	16.5332		16.5311	16.5336		
440	17.3228	17.3210	17.3202	17.3217	7 L		17.3197	17.3221	11 L	17.3191	17.3206	4 T	17.3185	17.3210	0 T	
460	18.1102	18.1084	18.1076	18.1091	26 T		18.1071	18.1095	31 T	18.1065	18.1080	37 T	18.1059	18.1084	43 T	
480	18.8976	18.8958	18.8950	18.8965			18.8945	18.8969		18.8939	18.8954		18.8933	18.8958		
500	19.6850	19.6832	19.6824	19.6839			19.6819	19.6843		19.6813	19.6828		19.6807	19.6832		
520	20.4724	20.4704	20.4689	20.4707			20.4679	20.4707		20.4676	20.4693		20.4666	20.4693		
540	21.2598	21.2578	21.2563	21.2581			21.2553	21.2581		21.2550	21.2567		21.2540	21.2567		
560	22.0472	22.0452	22.0438	22.0455	3 L		22.0430	22.0460	3 L	22.0420	22.0440	11 T	22.0414	22.0442	11 T	
580	22.8346	22.8326	22.8311	22.8329	35 T		22.8301	22.8329	45 T	22.8298	22.8315	48 T	22.8288	22.8315	58 T	
600	23.6220	23.6200	23.6185	23.6203			23.6175	23.6203		23.6172	23.6189		23.6162	23.6189		
620	24.4094	24.4074	24.4059	24.4077			24.4049	24.4077		24.4046	24.4063		24.4036	24.4063		
650	25.5906	25.5876	25.5867	25.5886			25.5855	25.5886		25.5852	25.5871		25.5840	25.5871		
670	26.3780	26.3750	26.3741	26.3760			26.3729	26.3760		26.3726	26.3745		26.3714	26.3745		
680	26.7717	26.7687	26.7678	26.7697			26.7666	26.7697		26.7663	26.7682		26.7651	26.7682		
700	27.5591	27.5561	27.5552	27.5571			27.5540	27.5571		27.5537	27.5556		27.5525	27.5556		
720	28.3465	28.3435	28.3426	28.3445	10 L		28.3414	28.3445	10 L	28.3411	28.3430	5 T	28.3399	28.3430	5 T	
750	29.5276	29.5246	29.5237	29.5256	39 T		29.5225	29.5256	51 T	29.5222	29.5241	54 T	29.5210	29.5241	66 T	
760	29.9213	29.9183	29.9173	29.9193			29.9160	29.9190		29.9160	29.9180		29.9146	29.9178		
780	30.7087	30.7057	30.7048	30.7067			30.7036	30.7077		30.7033	30.7052		30.7021	30.7052		
790	31.1024	31.0994	31.0985	31.1004			31.0973	31.1004		31.0970	31.0989		31.0958	31.0989		
800	31.4961	31.4931	31.4922	31.4941			31.4910	31.4940		31.4910	31.4930		31.4894	31.4926		
820	32.2835	32.2796	32.2791	32.2813			32.2778	32.2813		32.2774	32.2796		32.2760	32.2796		
830	32.6772	32.6733	32.6728	32.6750			32.6710	32.6750		32.6710	32.6730		32.6697	32.6732		
850	33.4646	33.4607	33.4602	33.4624			33.4589	33.4624		33.4585	33.4607		33.4571	33.4607		
870	34.2520	34.2481	34.2476	34.2498	17 L		34.2463	34.2498	17 L	34.2459	34.2481	0 T	34.2445	34.2481	0 T	
920	36.2205	36.2166	36.2161	36.2183	44 T		36.2148	36.2183	57 T	36.2144	36.2166	61 T	36.2130	36.2166	75 T	
950	37.4016	37.3977	37.3972	37.3994			37.3959	37.3994		37.3955	37.3977		37.3941	37.3977		
980	38.5827	38.5788	38.5783	38.5805			38.5770	38.5805		38.5766	38.5788		38.5752	38.5788		
1000	39.3701	39.3662	39.3657	39.3679			39.3644	39.3679		39.3640	39.3662		39.3626	39.3662		
1150	45.2756	45.2707	45.2704	45.2730	23 L		45.2689	45.2730	23 L	45.2683	45.2709	2 L	45.2667	45.2709	2 L	
1250	49.2126	49.2077	49.2074	49.2100	52 T		49.2059	49.2100	67 T	49.2053	49.2079	73 T	49.2037	49.2079	89 T	
1400	55.1181	55.1118	55.1120	55.1150	32 L		55.1101	55.1150	32 L	55.1095	55.1126	8 L	55.1077	55.1126	8 L	
1600	62.9921	62.9858	62.9860	62.9890	61 T		62.9841	62.9890	80 T	62.9835	62.9866	86 T	62.9817	62.9866	104 T	

¹⁾ Resultant fit in 0.0001 in. L indicates a clearance (loose) fit, T indicates an interference (tight) fit.

Modified shaft diameter deviations for use with inch bearings

Nominal diameter Shaft seat Bearing bore over incl.		Modified deviations for fits with clearance/interference according to tolerance class:											
		g6		h6		j5		j6		js6		k5	
mm	mm	high	low	high	low	high	low	high	low	high	low	high	low
		µm											
10	18	+2	-4	+8	+2	-13	+10	+16	+10	+14	+7	+17	+14
18	30	+3	-7	+10	0	+15	+9	+19	+9	+17	+6	+21	+15
30	50	+3	-12	+12	-3	+18	+8	+23	+8	+20	+5	+25	+15
50	76,2	+5	-16	+15	-6	+21	+6	+27	+6	+25	+3	+30	+15
76,2	80	+5	-4	+15	+6	+21	+18	+27	+18	+25	+15	+30	+27
80	120	+8	-9	+20	+3	+26	+16	+33	+16	+31	+14	+38	+28
120	180	+11	-14	+25	0	+32	+14	+39	+14	+38	+12	+46	+28
180	250	+15	-19	+30	-4	+37	+12	+46	+12	+45	+10	+54	+29
250	304,8	+18	-24	+35	-7	+42	+9	+51	+9	+51	+9	+62	+29
304,8	315	+18	+2	+35	+19	+42	+35	+51	+35	+51	+35	+62	+55
315	400	+22	-3	+40	+15	+47	+33	+58	+33	+58	+33	+69	+55
400	500	+25	-9	+45	+11	+52	+31	+65	+31	+65	+31	+77	+56
500	609,6	+28	-15	+50	+7	-	-	+72	+29	+72	+29	+78	+51
609,6	630	+28	+10	+50	+32	-	-	+72	+54	+72	+54	+78	+76
630	800	+51	+2	+75	+26	-	-	+100	+51	+100	+51	+107	+76
800	914,4	+74	-6	+100	+20	-	-	+128	+48	+128	+48	+136	+76
914,4	1000	+74	+20	+100	+46	-	-	+128	+74	+128	+74	+136	+102
1000	1219,2	+97	+8	+125	+36	-	-	+158	+69	+158	+69	+167	+102

Nominal diameter Shaft seat Bearing bore over incl.		Modified deviations for fits with clearance/interference according to tolerance class:									
		k6		m5		m6		n6		p6	
mm	mm	high	low	high	low	high	low	high	low	high	low
		µm									
10	18	+20	+14	+23	+20	+26	+20	+31	+25	+37	+31
18	30	+25	+15	+27	+21	+31	+21	+38	+28	+45	+35
30	50	+30	+15	+32	+22	+37	+22	+45	+30	+54	+39
50	76,2	+36	+15	+39	+24	+45	+24	+54	+33	+66	+45
76,2	80	+36	+27	+39	+36	+45	+36	+54	+45	+66	+57
80	120	+45	+28	+48	+38	+55	+38	+65	+48	+79	+62
120	180	+53	+28	+58	+40	+65	+40	+77	+52	+93	+68
180	250	+63	+29	+67	+42	+76	+42	+90	+56	+109	+75
250	304,8	+71	+29	+78	+45	+87	+45	+101	+59	+123	+81
304,8	315	+71	+55	+78	+71	+87	+71	+101	+85	+123	+107
315	400	+80	+55	+86	+72	+97	+72	+113	+88	+138	+113
400	500	+90	+56	+95	+74	+108	+74	+125	+91	+153	+119
500	609,6	+94	+51	+104	+77	+120	+77	+138	+95	+172	+129
609,6	630	+94	+76	+104	+102	+120	+102	+138	+120	+172	+154
630	800	+125	+76	+137	+106	+155	+106	+175	+126	+213	+164
800	914,4	+156	+76	+170	+110	+190	+110	+212	+132	+256	+176
914,4	1000	+156	+102	+170	+136	+190	+136	+212	+158	+256	+202
1000	1219,2	+191	+102	+207	+142	+231	+142	+257	+168	+311	+222

Modified housing bore diameter deviations for use with inch bearings

Nominal diameter Modified deviations for fits with clearance/interference according to tolerance class:

Nominal diameter		Modified deviations for fits with clearance/interference according to tolerance class:									
Housing bore seat		H7		J7		J6		K6		K7	
over	incl.	high	low	high	low	high	low	high	low	high	low
Bearing outside diameter		µm									
mm		µm									
30	50	+36	+25	+25	+14	+21	+19	+14	+12	+18	+7
50	80	+43	+25	+31	+13	+26	+19	+17	+10	+22	+4
80	120	+50	+25	+37	+12	+31	+19	+19	+7	+25	0
120	150	+58	+25	+44	+11	+36	+18	+22	+4	+30	-3
150	180	+65	+25	+51	+11	+43	+18	+29	+4	+37	-3
180	250	+76	+25	+60	+9	+52	+18	+35	+1	+43	-8
250	304,8	+87	+25	+71	+9	+60	+18	+40	-2	+51	-11
304,8	315	+87	+51	+71	+35	+60	+44	+40	+24	+51	+15
315	400	+97	+51	+79	+33	+69	+44	+47	+22	+57	+11
400	500	+108	+51	+88	+31	+78	+44	+53	+19	+63	+6
500	609,6	+120	+51	-	-	-	-	+50	+7	+50	-19
609,6	630	+120	+76	-	-	-	-	+50	+32	+50	+6
630	800	+155	+76	-	-	-	-	+75	+26	+75	-4
800	914,4	+190	+76	-	-	-	-	+100	+20	+100	-14
914,4	1 000	+190	+102	-	-	-	-	+100	+46	+100	+12
1 000	1 219,2	+230	+102	-	-	-	-	+125	+36	+125	-3
1 219,2	1 250	+230	+127	-	-	-	-	+125	+61	+125	+22
1 250	1 600	+285	+127	-	-	-	-	+160	+49	+160	+2

Nominal diameter Modified deviations for fits with clearance/interference according to tolerance class:

Nominal diameter		Modified deviations for fits with clearance/interference according to tolerance class:							
Housing bore seat		M6		M7		N7		P7	
over	incl.	high	low	high	low	high	low	high	low
Bearing outside diameter		µm							
mm		µm							
30	50	+7	+5	+11	0	+3	-8	-6	-17
50	80	+8	+1	+13	-5	+4	-14	-8	-26
80	120	+9	-3	+15	-10	+5	-20	-9	-34
120	150	+10	-8	+18	-15	+6	-27	-10	-43
150	180	+17	-8	+25	-15	+13	-27	-3	-43
180	250	+22	-12	+30	-21	+16	-35	-3	-54
250	304,8	+26	-16	+35	-27	+21	-41	-1	-63
304,8	315	+26	+10	+35	-1	+21	-15	-1	-37
315	400	+30	+5	+40	-6	+24	-22	-1	-47
400	500	+35	+1	+45	-12	+28	-29	0	-57
500	609,6	+24	-19	+24	-45	+6	-63	-28	-97
609,6	630	+24	+6	+24	-20	+6	-38	-28	-72
630	800	+45	-4	+45	-34	+25	-54	-13	-92
800	914,4	+66	-14	+66	-48	+44	-70	0	-114
914,4	1 000	+66	+12	+66	-22	+44	-44	0	-88
1 000	1 219,2	+85	-4	+85	-43	+59	-69	+5	-123
1 219,2	1 250	+85	+21	+85	-18	+59	-44	+5	-98
1 250	1 600	+112	+1	+112	-46	+82	-76	+20	-138

Shaft diameter and form tolerances for sleeve mounting

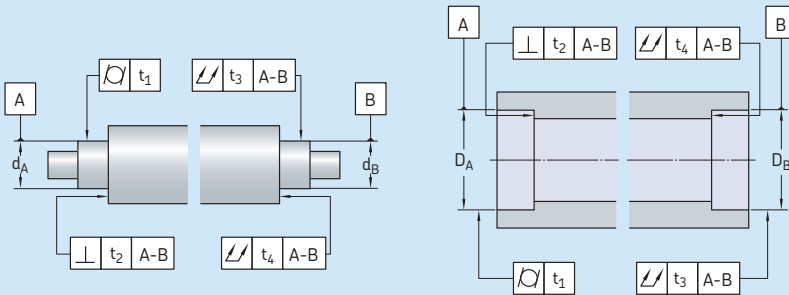
Shaft diameter d		Diameter and form tolerances		
		Tolerance class h9 Deviations		Tolerance grade [T5 ¹⁾
Nominal over	incl.	high	low	max
mm		µm		
10	18	0	-43	8
18	30	0	-52	9
30	50	0	-62	11
50	80	0	-74	13
80	120	0	-87	15
120	180	0	-100	18
180	250	0	-115	20
250	315	0	-130	23
315	400	0	-140	25
400	500	0	-155	27
500	630	0	-175	32
630	800	0	-200	36
800	1 000	0	-230	40
1 000	1 250	0	-260	47

¹⁾ The recommendation is for tolerance grade IT5/2, because the tolerance zone t is a radius. However, in the table above the values relate to a nominal shaft diameter and are therefore not halved.

ISO tolerance grades

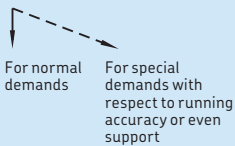
Nominal dimension		Tolerance grades			IT4	IT5	IT6	IT7	IT8	IT9	IT10	IT11	IT12
over	incl.	IT1 max	IT2	IT3									
mm		µm											
1	3	0,8	1,2	2	3	4	6	10	14	25	40	60	100
3	6	1	1,5	2,5	4	5	8	12	18	30	48	75	120
6	10	1	1,5	2,5	4	6	9	15	22	36	58	90	150
10	18	1,2	2	3	5	8	11	18	27	43	70	110	180
18	30	1,5	2,5	4	6	9	13	21	33	52	84	130	210
30	50	1,5	2,5	4	7	11	16	25	39	62	100	160	250
50	80	2	3	5	8	13	19	30	46	74	120	190	300
80	120	2,5	4	6	10	15	22	35	54	87	140	220	350
120	180	3,5	5	8	12	18	25	40	63	100	160	250	400
180	250	4,5	7	10	14	20	29	46	72	115	185	290	460
250	315	6	8	12	16	23	32	52	81	130	210	320	520
315	400	7	9	13	18	25	36	57	89	140	230	360	570
400	500	8	10	15	20	27	40	63	97	155	250	400	630
500	630	–	–	–	–	32	44	70	110	175	280	440	700
630	800	–	–	–	–	36	50	80	125	200	320	500	800
800	1000	–	–	–	–	40	56	90	140	230	360	560	900
1000	1250	–	–	–	–	47	66	105	165	260	420	660	1050
1250	1600	–	–	–	–	55	78	125	195	310	500	780	1250
1600	2000	–	–	–	–	65	92	150	230	370	600	920	1500
2000	2500	–	–	–	–	78	110	175	280	440	700	1100	1750

Accuracy of form and position of bearing seats



Surface Characteristic	Symbol for characteristic	tolerance zone	Permissible deviations			
			Bearings of tolerance class ¹⁾			
			Normal, CLN	P6	P5	
Cylindrical seat						
Cylindricity		t ₁	IT5/2	IT4/2	IT3/2	IT2/2
Total radial runout		t ₃	IT5/2	IT4/2	IT3/2	IT2/2
Flat abutment						
Perpendicularity		t ₂	IT5	IT4	IT3	IT2
Total axial runout		t ₄	IT5	IT4	IT3	IT2

Explanation



¹⁾ For bearings of higher accuracy (tolerance class P4 etc.), visit www.skf.com/bearings.

Appendix D-2

Surface roughness of bearing seats

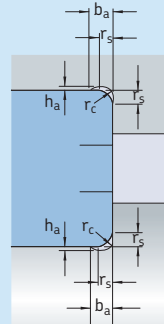
Diameter of seats d (D) ¹⁾		Recommended R _a value for ground seats		
		Diameter tolerance grade to		
over	incl.	IT7	IT6	IT5
mm		μm		
–	80	1,6	0,8	0,4
80	500	1,6	1,6	0,8
500	1 250	3,2 ²⁾	1,6	1,6

¹⁾ For diameters > 1 250 mm contact the SKF application engineering service.

²⁾ When using the oil injection method for mounting, R_a should not exceed 1,6 mm.

Appendix D-3

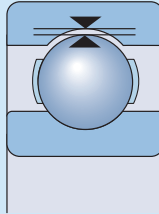
Dimensions for relieved fillets



Bearing chamfer dimension

r _s	Fillet dimensions		
	b _a	h _a	r _c
mm	mm		
1	2	0,2	1,3
1,1	2,4	0,3	1,5
1,5	3,2	0,4	2
2	4	0,5	2,5
2,1	4	0,5	2,5
3	4,7	0,5	3
4	5,9	0,5	4
5	7,4	0,6	5
6	8,6	0,6	6
7,5	10	0,6	7
9,5	12	0,6	9

Radial internal clearance of deep groove ball bearings

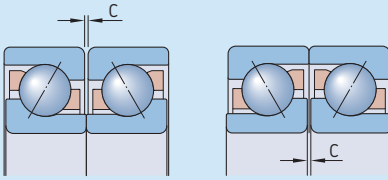


Bore diameter d		Radial internal clearance C2				Normal		C3		C4		C5	
over	incl.	min	max	min	max	min	max	min	max	min	max	min	max
mm		μm											
2,5	6 ¹⁾	0	7	2	13	8	23	-	-	-	-	-	-
6	10 ¹⁾	0	7	2	13	8	23	14	29	20	37		
10	18	0	9	3	18	11	25	18	33	25	45		
18	24	0	10	5	20	13	28	20	36	28	48		
24	30	1	11	5	20	13	28	23	41	30	53		
30	40	1	11	6	20	15	33	28	46	40	64		
40	50	1	11	6	23	18	36	30	51	45	73		
50	65	1	15	8	28	23	43	38	61	55	90		
65	80	1	15	10	30	25	51	46	71	65	105		
80	100	1	18	12	36	30	58	53	84	75	120		
100	120	2	20	15	41	36	66	61	97	90	140		
120	140	2	23	18	48	41	81	71	114	105	160		
140	160	2	23	18	53	46	91	81	130	120	180		
160	180	2	25	20	61	53	102	91	147	135	200		
180	200	2	30	25	71	63	117	107	163	150	230		
200	225	2	35	25	85	75	140	125	195	175	265		
225	250	2	40	30	95	85	160	145	225	205	300		
250	280	2	45	35	105	90	170	155	245	225	340		
280	315	2	55	40	115	100	190	175	270	245	370		
315	355	3	60	45	125	110	210	195	300	275	410		
355	400	3	70	55	145	130	240	225	340	315	460		
400	450	3	80	60	170	150	270	250	380	350	520		
450	500	3	90	70	190	170	300	280	420	390	570		
500	560	10	100	80	210	190	330	310	470	440	630		
560	630	10	110	90	230	210	360	340	520	490	700		
630	710	20	130	110	260	240	400	380	570	540	780		
710	800	20	140	120	290	270	450	430	630	600	860		
800	900	20	160	140	320	300	500	480	700	670	960		
900	1 000	20	170	150	350	330	550	530	770	740	1 040		
1 000	1 120	20	180	160	380	360	600	580	850	820	1 150		
1 120	1 250	20	190	170	410	390	650	630	920	890	1 260		
1 250	1 400	30	200	190	440	420	700	680	1 000	-	-		
1 400	1 600	30	210	210	470	450	750	730	1 060	-	-		

¹⁾ The clearance values are not valid for stainless steel deep groove ball bearings with a bore diameter d < 10 mm.

Appendix E-2

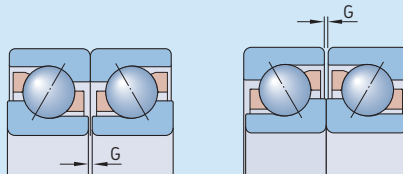
Axial internal clearance of universally matchable single row angular contact ball bearings arranged back-to-back or face-to-face



Bore diameter d		Axial internal clearance Class							
over	incl.	CA		CB		CC			
		min	max	min	max	min	max		
mm		μm							
10	18	5	13	15	23	24	32		
18	30	7	15	18	26	32	40		
30	50	9	17	22	30	40	48		
50	80	11	23	26	38	48	60		
80	120	14	26	32	44	55	67		
120	180	17	29	35	47	62	74		
180	250	21	37	45	61	74	90		

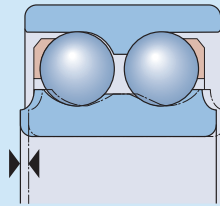
Appendix E-3

Axial preload of universally matchable single row angular contact ball bearings arranged back-to-back or face-to-face



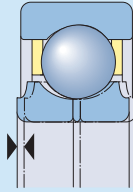
Bore diameter d		Preload Class GA				GB				GC			
over	incl.	min	max	max	min	max	min	max	min	max	min	max	
mm		μm				N				μm			
10	18	+4	-4	80	-2	-10	30	330	-8	-16	230	660	
18	30	+4	-4	120	-2	-10	40	480	-8	-16	340	970	
30	50	+4	-4	160	-2	-10	60	630	-8	-16	450	1280	
50	80	+6	-6	380	-3	-15	140	1500	-12	-24	1080	3050	
80	120	+6	-6	410	-3	-15	150	1600	-12	-24	1150	3250	
120	180	+6	-6	540	-3	-15	200	2150	-12	-24	1500	4300	
180	250	+8	-8	940	-4	-20	330	3700	-16	-32	2650	7500	

Axial internal clearance of double row angular contact ball bearings



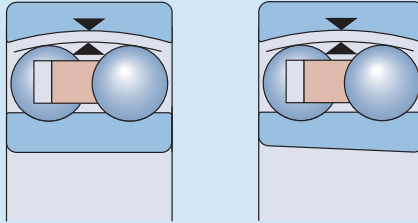
Bore diameter		Axial internal clearance of bearings in the series						33 D		33 DNRCBM	
d	incl.	C2		Normal		C3		min	max	min	max
mm		min	max	min	max	min	max	μm		μm	
-	10	1	11	5	21	12	28	-	-	-	-
10	18	1	12	6	23	13	31	-	-	-	-
18	24	2	14	7	25	16	34	-	-	-	-
24	30	2	15	8	27	18	37	-	-	-	-
30	40	2	16	9	29	21	40	33	54	10	30
40	50	2	18	11	33	23	44	36	58	10	30
50	65	3	22	13	36	26	48	40	63	18	38
65	80	3	24	15	40	30	54	46	71	18	38
80	100	3	26	18	46	35	63	55	83	-	-
100	110	4	30	22	53	42	73	65	96	-	-

Axial internal clearance of four-point contact ball bearings



Bore diameter d		Axial internal clearance							
		C2		Normal		C3		C4	
over	incl.	min	max	min	max	min	max	min	max
mm		μm							
10	17	15	55	45	85	75	125	115	165
17	40	26	66	56	106	96	146	136	186
40	60	36	86	76	126	116	166	156	206
60	80	46	96	86	136	126	176	166	226
80	100	56	106	96	156	136	196	186	246
100	140	66	126	116	176	156	216	206	266
140	180	76	156	136	196	176	246	226	296
180	220	96	176	156	226	206	276	256	326

Radial internal clearance of self-aligning ball bearings



Bore diameter d		Radial internal clearance C2				C3		C4	
over	incl.	min	max	Normal		min	max	min	max
mm		μm							

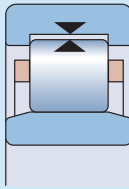
Bearings with a cylindrical bore

2,5	6	1	8	5	15	10	20	15	25
6	10	2	9	6	17	12	25	19	33
10	14	2	10	6	19	13	26	21	35
14	18	3	12	8	21	15	28	23	37
18	24	4	14	10	23	17	30	25	39
24	30	5	16	11	24	19	35	29	46
30	40	6	18	13	29	23	40	34	53
40	50	6	19	14	31	25	44	37	57
50	65	7	21	16	36	30	50	45	69
65	80	8	24	18	40	35	60	54	83
80	100	9	27	22	48	42	70	64	96
100	120	10	31	25	56	50	83	75	114
120	140	10	38	30	68	60	100	90	135
140	160	15	44	35	80	70	120	110	161
160	180	15	50	40	92	82	138	126	185
180	200	17	57	47	105	93	157	144	212
200	225	18	62	50	115	100	170	155	230
225	250	20	70	57	130	115	195	175	255

Bearings with a tapered bore

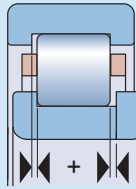
18	24	7	17	13	26	20	33	28	42
24	30	9	20	15	28	23	39	33	50
30	40	12	24	19	35	29	46	40	59
40	50	14	27	22	39	33	52	45	65
50	65	18	32	27	47	41	61	56	80
65	80	23	39	35	57	50	75	69	98
80	100	29	47	42	68	62	90	84	116
100	120	35	56	50	81	75	108	100	139

Radial internal clearance of cylindrical and needle roller bearings



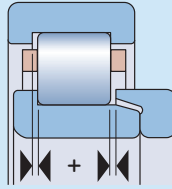
Bore diameter d		Radial internal clearance									
		C2		Normal		C3		C4		C5	
over	incl.	min	max	min	max	min	max	min	max	min	max
mm		μm									
–	10	0	25	20	45	35	60	50	75	–	–
10	24	0	25	20	45	35	60	50	75	65	90
24	30	0	25	20	45	35	60	50	75	70	95
30	40	5	30	25	50	45	70	60	85	80	105
40	50	5	35	30	60	50	80	70	100	95	125
50	65	10	40	40	70	60	90	80	110	110	140
65	80	10	45	40	75	65	100	90	125	130	165
80	100	15	50	50	85	75	110	105	140	155	190
100	120	15	55	50	90	85	125	125	165	180	220
120	140	15	60	60	105	100	145	145	190	200	245
140	160	20	70	70	120	115	165	165	215	225	275
160	180	25	75	75	125	120	170	170	220	250	300
180	200	35	90	90	145	140	195	195	250	275	330
200	225	45	105	105	165	160	220	220	280	305	365
225	250	45	110	110	175	170	235	235	300	330	395
250	280	55	125	125	195	190	260	260	330	370	440
280	315	55	130	130	205	200	275	275	350	410	485
315	355	65	145	145	225	225	305	305	385	455	535
355	400	100	190	190	280	280	370	370	460	510	600
400	450	110	210	210	310	310	410	410	510	565	665
450	500	110	220	220	330	330	440	440	550	625	735
500	560	120	240	240	360	360	480	480	600	690	810
560	630	140	260	260	380	380	500	500	620	780	900
630	710	145	285	285	425	425	565	565	705	865	1 005
710	800	150	310	310	470	470	630	630	790	975	1 135
800	900	180	350	350	520	520	690	690	860	1 095	1 265
900	1 000	200	390	390	580	580	770	770	960	–	–
1 000	1 120	220	430	430	640	640	850	850	1 060	–	–
1 120	1 250	230	470	470	710	710	950	950	1 190	–	–
1 250	1 400	270	530	530	790	790	1 050	1 050	1 310	–	–
1 400	1 600	330	610	610	890	890	1 170	1 170	1 450	–	–
1 600	1 800	380	700	700	1 020	1 020	1 340	1 340	1 660	–	–
1 800	2 000	400	760	760	1 120	1 120	1 480	1 480	1 840	–	–

Axial internal clearance of NUP cylindrical roller bearings



Bearing Bore diameter	Size code	Axial internal clearance of bearings in the series							
		NUP 2		NUP 3		NUP 22		NUP 23	
mm	–	min	max	min	max	min	max	min	max
		μm							
17	03	37	140	37	140	37	140	47	155
20	04	37	140	37	140	47	155	47	155
25	05	37	140	47	155	47	155	47	155
30	06	37	140	47	155	47	155	47	155
35	07	47	155	47	155	47	155	62	180
40	08	47	155	47	155	47	155	62	180
45	09	47	155	47	155	47	155	62	180
50	10	47	155	47	155	47	155	62	180
55	11	47	155	62	180	47	155	62	180
60	12	47	155	62	180	62	180	87	230
65	13	47	155	62	180	62	180	87	230
70	14	47	155	62	180	62	180	87	230
75	15	47	155	62	180	62	180	87	230
80	16	47	155	62	180	62	180	87	230
85	17	62	180	62	180	62	180	87	230
90	18	62	180	62	180	62	180	87	230
95	19	62	180	62	180	62	180	87	230
100	20	62	180	87	230	87	230	120	315
105	21	62	180	–	–	–	–	–	–
110	22	62	180	87	230	87	230	120	315
120	24	62	180	87	230	87	230	120	315
130	26	62	180	87	230	87	230	120	315
140	28	62	180	87	230	87	230	120	315
150	30	62	180	–	–	87	230	120	315
160	32	87	230	–	–	–	–	–	–
170	34	87	230	–	–	–	–	–	–
180	36	87	230	–	–	–	–	–	–
190	38	87	230	–	–	–	–	–	–
200	40	87	230	–	–	–	–	–	–
220	44	95	230	–	–	–	–	–	–
240	48	95	250	–	–	–	–	–	–
260	52	95	250	–	–	–	–	–	–

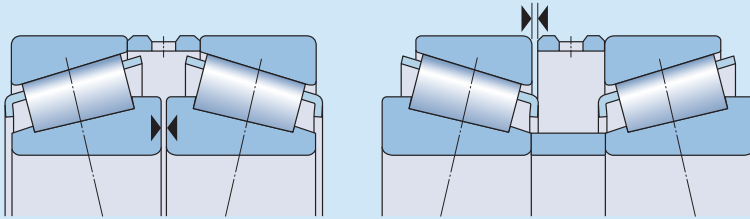
Axial internal clearance of NJ + HJ cylindrical roller bearings



Bearing Bore diameter	Size code	Axial internal clearance of bearings in the series									
		NJ 2+HJ 2		NJ 3+HJ 3		NJ 4+HJ 4		NJ 22+HJ 22		NJ 23+HJ 23	
mm	–	μm									
		min	max	min	max	min	max	min	max	min	max
20	04	42	165	42	165	–	–	52	185	52	183
25	05	42	165	52	185	–	–	52	185	52	183
30	06	42	165	52	185	60	200	52	185	52	183
35	07	52	185	52	185	60	200	52	185	72	215
40	08	52	185	52	185	60	200	52	185	72	215
45	09	52	185	52	185	60	200	52	185	72	215
50	10	52	185	52	185	80	235	52	185	72	215
55	11	52	185	72	215	80	235	52	185	72	215
60	12	52	185	72	215	80	235	72	215	102	275
65	13	52	185	72	215	80	235	72	215	102	275
70	14	52	185	72	215	80	235	72	215	102	275
75	15	52	185	72	215	80	235	72	215	102	275
80	16	52	185	72	215	80	235	72	215	102	275
85	17	72	215	72	215	110	290	72	215	102	275
90	18	72	215	72	215	110	290	72	215	102	275
95	19	72	215	72	215	110	290	72	215	102	275
100	20	72	215	102	275	110	290	102	275	140	375
105	21	72	215	102	275	110	290	102	275	140	375
110	22	72	215	102	275	110	290	102	275	140	375
120	24	72	215	102	275	110	310	102	275	140	375
130	26	72	215	102	275	110	310	102	275	140	375
140	28	72	215	102	275	140	385	102	275	140	375
150	30	72	215	102	275	140	385	102	275	140	375
160	32	102	275	102	275	–	–	140	375	140	375
170	34	102	275	–	–	–	–	140	375	–	–
180	36	102	275	–	–	–	–	140	375	–	–
190	38	102	275	–	–	–	–	–	–	–	–
200	40	102	275	–	–	–	–	–	–	–	–
220	44	110	290	–	–	–	–	–	–	–	–
240	48	110	310	–	–	–	–	–	–	–	–
260	52	110	310	–	–	–	–	–	–	–	–
280	56	110	310	–	–	–	–	–	–	–	–

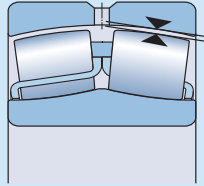
For bearings not listed, contact the SKF application engineering service.

Axial internal clearance of matched single row metric tapered roller bearings



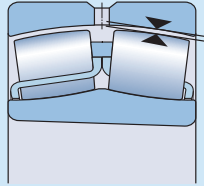
Bore diameter d		Axial internal clearance of bearings in the series											
		329		320		330		331, 302, 322, 332		303, 323		313	
over	incl.	min	max	min	max	min	max	min	max	min	max	min	max
mm		µm											
-	30	-	-	80	120	-	-	100	140	130	170	60	100
30	40	-	-	100	140	-	-	120	160	140	180	70	110
40	50	-	-	120	160	180	220	140	180	160	200	80	120
50	65	-	-	140	180	200	240	160	200	180	220	100	140
65	80	-	-	160	200	250	290	180	220	200	260	110	170
80	100	270	310	190	230	350	390	210	270	240	300	110	170
100	120	270	330	220	280	340	400	220	280	280	340	130	190
120	140	310	370	240	300	340	400	240	300	330	390	160	220
140	160	370	430	270	330	340	400	270	330	370	430	180	240
160	180	370	430	310	370	-	-	310	370	390	450	-	-
180	190	370	430	340	400	-	-	340	400	440	500	-	-
190	200	390	450	340	400	-	-	340	400	440	500	-	-
200	225	440	500	390	450	-	-	390	450	490	550	-	-
225	250	440	500	440	500	-	-	440	500	540	600	-	-
250	280	540	600	490	550	-	-	490	550	-	-	-	-
280	300	640	700	540	600	-	-	540	600	-	-	-	-
300	340	640	700	590	650	-	-	590	650	-	-	-	-

Radial internal clearance of spherical roller bearings with a cylindrical bore



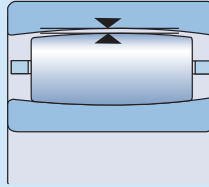
Bore diameter d		Radial internal clearance									
over	incl.	C2		Normal		C3		C4		C5	
		min	max	min	max	min	max	min	max	min	max
mm		μm									
14	18	10	20	20	35	35	45	45	60	60	75
18	24	10	20	20	35	35	45	45	60	60	75
24	30	15	25	25	40	40	55	55	75	75	95
30	40	15	30	30	45	45	60	60	80	80	100
40	50	20	35	35	55	55	75	75	100	100	125
50	65	20	40	40	65	65	90	90	120	120	150
65	80	30	50	50	80	80	110	110	145	145	185
80	100	35	60	60	100	100	135	135	180	180	225
100	120	40	75	75	120	120	160	160	210	210	260
120	140	50	95	95	145	145	190	190	240	240	300
140	160	60	110	110	170	170	220	220	280	280	350
160	180	65	120	120	180	180	240	240	310	310	390
180	200	70	130	130	200	200	260	260	340	340	430
200	225	80	140	140	220	220	290	290	380	380	470
225	250	90	150	150	240	240	320	320	420	420	520
250	280	100	170	170	260	260	350	350	460	460	570
280	315	110	190	190	280	280	370	370	500	500	630
315	355	120	200	200	310	310	410	410	550	550	690
355	400	130	220	220	340	340	450	450	600	600	750
400	450	140	240	240	370	370	500	500	660	660	820
450	500	140	260	260	410	410	550	550	720	720	900
500	560	150	280	280	440	440	600	600	780	780	1000
560	630	170	310	310	480	480	650	650	850	850	1100
630	710	190	350	350	530	530	700	700	920	920	1190
710	800	210	390	390	580	580	770	770	1010	1010	1300
800	900	230	430	430	650	650	860	860	1120	1120	1440
900	1000	260	480	480	710	710	930	930	1220	1220	1570
1000	1120	290	530	530	780	780	1020	1020	1330	1330	1720
1120	1250	320	580	580	860	860	1120	1120	1460	1460	1870
1250	1400	350	640	640	950	950	1240	1240	1620	1620	2060
1400	1600	400	720	720	1060	1060	1380	1380	1800	1800	2300
1600	1800	450	810	810	1180	1180	1550	1550	2000	2000	2550

Radial internal clearance of spherical roller bearings with a tapered bore



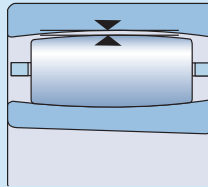
Bore diameter d		Radial internal clearance									
over	incl.	C2		Normal		C3		C4		C5	
		min	max	min	max	min	max	min	max	min	max
mm		μm									
18	24	15	25	25	35	35	45	45	60	60	75
24	30	20	30	30	40	40	55	55	75	75	95
30	40	25	35	35	50	50	65	65	85	85	105
40	50	30	45	45	60	60	80	80	100	100	130
50	65	40	55	55	75	75	95	95	120	120	160
65	80	50	70	70	95	95	120	120	150	150	200
80	100	55	80	80	110	110	140	140	180	180	230
100	120	65	100	100	135	135	170	170	220	220	280
120	140	80	120	120	160	160	200	200	260	260	330
140	160	90	130	130	180	180	230	230	300	300	380
160	180	100	140	140	200	200	260	260	340	340	430
180	200	110	160	160	220	220	290	290	370	370	470
200	225	120	180	180	250	250	320	320	410	410	520
225	250	140	200	200	270	270	350	350	450	450	570
250	280	150	220	220	300	300	390	390	490	490	620
280	315	170	240	240	330	330	430	430	540	540	680
315	355	190	270	270	360	360	470	470	590	590	740
355	400	210	300	300	400	400	520	520	650	650	820
400	450	230	330	330	440	440	570	570	720	720	910
450	500	260	370	370	490	490	630	630	790	790	1 000
500	560	290	410	410	540	540	680	680	870	870	1 100
560	630	320	460	460	600	600	760	760	980	980	1 230
630	710	350	510	510	670	670	850	850	1 090	1 090	1 360
710	800	390	570	570	750	750	960	960	1 220	1 220	1 500
800	900	440	640	640	840	840	1 070	1 070	1 370	1 370	1 690
900	1 000	490	710	710	930	930	1 190	1 190	1 520	1 520	1 860
1 000	1 120	530	770	770	1 030	1 030	1 300	1 300	1 670	1 670	2 050
1 120	1 250	570	830	830	1 120	1 120	1 420	1 420	1 830	1 830	2 250
1 250	1 400	620	910	910	1 230	1 230	1 560	1 560	2 000	2 000	2 450
1 400	1 600	680	1 000	1 000	1 350	1 350	1 720	1 720	2 200	2 200	2 700
1 600	1 800	750	1 110	1 110	1 500	1 500	1 920	1 920	2 400	2 400	2 950

Radial internal clearance of CARB toroidal roller bearings with a cylindrical bore



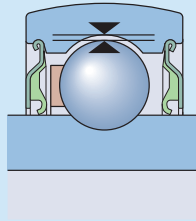
Bore diameter d		Radial internal clearance C2				Normal		C3		C4		C5	
over	incl.	min	max	min	max	min	max	min	max	min	max	min	max
mm		μm											
18	24	15	30	25	40	35	55	50	65	65	85		
24	30	15	35	30	50	45	60	60	80	75	95		
30	40	20	40	35	55	55	75	70	95	90	120		
40	50	25	45	45	65	65	85	85	110	105	140		
50	65	30	55	50	80	75	105	100	140	135	175		
65	80	40	70	65	100	95	125	120	165	160	210		
80	100	50	85	80	120	120	160	155	210	205	260		
100	120	60	100	100	145	140	190	185	245	240	310		
120	140	75	120	115	170	165	215	215	280	280	350		
140	160	85	140	135	195	195	250	250	325	320	400		
160	180	95	155	150	220	215	280	280	365	360	450		
180	200	105	175	170	240	235	310	305	395	390	495		
200	225	115	190	185	265	260	340	335	435	430	545		
225	250	125	205	200	285	280	370	365	480	475	605		
250	280	135	225	220	310	305	410	405	520	515	655		
280	315	150	240	235	330	330	435	430	570	570	715		
315	355	160	260	255	360	360	485	480	620	620	790		
355	400	175	280	280	395	395	530	525	675	675	850		
400	450	190	310	305	435	435	580	575	745	745	930		
450	500	205	335	335	475	475	635	630	815	810	1015		
500	560	220	360	360	520	510	690	680	890	890	1110		
560	630	240	400	390	570	560	760	750	980	970	1220		
630	710	260	440	430	620	610	840	830	1080	1070	1340		
710	800	300	500	490	680	680	920	920	1200	1200	1480		
800	900	320	540	530	760	750	1020	1010	1330	1320	1660		
900	1000	370	600	590	830	830	1120	1120	1460	1460	1830		
1000	1120	410	660	660	930	930	1260	1260	1640	1640	2040		
1120	1250	450	720	720	1020	1020	1380	1380	1800	1800	2240		
1250	1400	490	800	800	1130	1130	1510	1510	1970	1970	2460		
1400	1600	570	890	890	1250	1250	1680	1680	2200	2200	2740		
1600	1800	650	1010	1010	1390	1390	1870	1870	2430	2430	3000		

Radial internal clearance of CARB toroidal roller bearings with a tapered bore



Bore diameter d		Radial internal clearance C2				Normal		C3		C4		C5	
over	incl.	min	max	min	max	min	max	min	max	min	max	min	max
mm		μm											
18	24	15	35	30	45	40	55	55	70	65	85	65	85
24	30	20	40	35	55	50	65	65	85	80	100	80	100
30	40	25	50	45	65	60	80	80	100	100	125	100	125
40	50	30	55	50	75	70	95	90	120	115	145	115	145
50	65	40	65	60	90	85	115	110	150	145	185	145	185
65	80	50	80	75	110	105	140	135	180	175	220	175	220
80	100	60	100	95	135	130	175	170	220	215	275	215	275
100	120	75	115	115	155	155	205	200	255	255	325	255	325
120	140	90	135	135	180	180	235	230	295	290	365	290	365
140	160	100	155	155	215	210	270	265	340	335	415	335	415
160	180	115	175	170	240	235	305	300	385	380	470	380	470
180	200	130	195	190	260	260	330	325	420	415	520	415	520
200	225	140	215	210	290	285	365	360	460	460	575	460	575
225	250	160	235	235	315	315	405	400	515	510	635	510	635
250	280	170	260	255	345	340	445	440	560	555	695	555	695
280	315	195	285	280	380	375	485	480	620	615	765	615	765
315	355	220	320	315	420	415	545	540	680	675	850	675	850
355	400	250	350	350	475	470	600	595	755	755	920	755	920
400	450	280	385	380	525	525	655	650	835	835	1005	835	1005
450	500	305	435	435	575	575	735	730	915	910	1115	910	1115
500	560	330	480	470	640	630	810	800	1010	1000	1230	1000	1230
560	630	380	530	530	710	700	890	880	1110	1110	1350	1110	1350
630	710	420	590	590	780	770	990	980	1230	1230	1490	1230	1490
710	800	480	680	670	860	860	1100	1100	1380	1380	1660	1380	1660
800	900	520	740	730	960	950	1220	1210	1530	1520	1860	1520	1860
900	1000	580	820	810	1040	1040	1340	1340	1670	1670	2050	1670	2050
1000	1120	640	900	890	1170	1160	1500	1490	1880	1870	2280	1870	2280
1120	1250	700	980	970	1280	1270	1640	1630	2060	2050	2500	2050	2500
1250	1400	770	1080	1080	1410	1410	1790	1780	2250	2250	2740	2250	2740
1400	1600	870	1200	1200	1550	1550	1990	1990	2500	2500	3050	2500	3050
1600	1800	950	1320	1320	1690	1690	2180	2180	2730	2730	3310	2730	3310

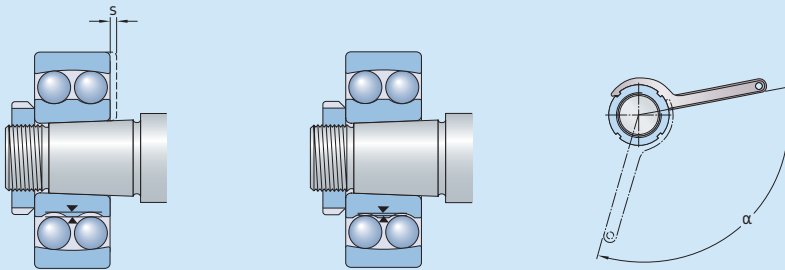
Radial internal clearance of Y-bearings



Bearing size ¹⁾		Radial internal clearance of Y-bearings in the series					
		YAT 2, YAR 2, YET 2, YEL 2, YHC 2		YSA 2 K		17262(00) 17263(00)	
from	to	min	max	min	max	min	max
–		μm					
03	03	10	25	–	–	3	18
04	04	12	28	–	–	5	20
05	06	12	28	23	41	5	20
07	08	13	33	28	46	6	20
09	10	14	36	30	51	6	23
11	13	18	43	38	61	8	28
14	16	20	51	–	–	–	–
17	20	24	58	–	–	–	–

¹⁾ For example: bearing size 06 includes all bearings based on a Y 206 bearing, such as YAR 206-101-2F, YAR 206-102-2F, YAR 206-2F, YAR 206-103-2F, YAR 206-104-2F.

Drive-up data for self-aligning ball bearings with a tapered bore

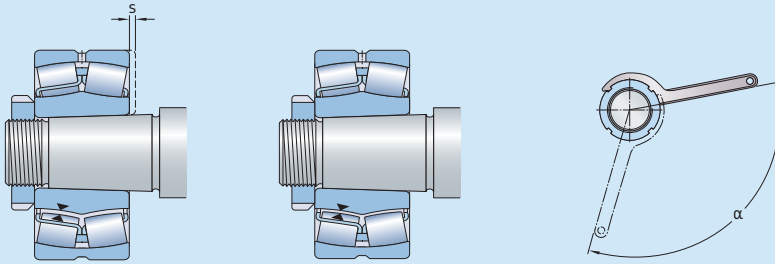


Bore diameter d	Axial drive-up s ¹⁾	Lock nut tightening angle α
mm	mm	degrees
20	0,22	80
25	0,22	55
30	0,22	55
35	0,30	70
40	0,30	70
45	0,35	80
50	0,35	80
55	0,40	75
60	0,40	75
65	0,40	80
70	0,40	80
75	0,45	85
80	0,45	85
85	0,60	110
90	0,60	110
95	0,60	110
100	0,60	110
110	0,70	125
120	0,70	125

Valid only for solid steel shafts and general applications. The listed values are to be used as guideline values only, as it is difficult to establish an exact starting position. Also the axial drive-up s differs slightly between the different bearings series.

¹⁾ Not valid for the SKF Drive-up Method.

Drive-up data for spherical roller bearings with a tapered bore



Bore diameter		Reduction of radial internal clearance		Axial drive-up $s^{1),2)}$				Lock nut tightening angle ²⁾
over	incl.	min	max	Taper 1:12		Taper 1:30		Taper 1:12
mm	mm	mm	mm	mm	mm	mm	mm	degrees
24	30	0,010	0,015	0,25	0,29	–	–	100
30	40	0,015	0,020	0,30	0,35	–	–	115
40	50	0,020	0,025	0,37	0,44	–	–	130
50	65	0,025	0,035	0,45	0,54	1,15	1,35	115
65	80	0,035	0,040	0,55	0,65	1,40	1,65	130
80	100	0,040	0,050	0,66	0,79	1,65	2,00	150
100	120	0,050	0,060	0,79	0,95	2,00	2,35	
120	140	0,060	0,075	0,93	1,10	2,30	2,80	
140	160	0,070	0,085	1,05	1,30	2,65	3,20	
160	180	0,080	0,095	1,20	1,45	3,00	3,60	
180	200	0,090	0,105	1,30	1,60	3,30	4,00	
200	225	0,100	0,120	1,45	1,80	3,70	4,45	
225	250	0,110	0,130	1,60	1,95	4,00	4,85	
250	280	0,120	0,150	1,80	2,15	4,50	5,40	
280	315	0,135	0,165	2,00	2,40	4,95	6,00	
315	355	0,150	0,180	2,15	2,65	5,40	6,60	
355	400	0,170	0,210	2,50	3,00	6,20	7,60	
400	450	0,195	0,235	2,80	3,40	7,00	8,50	
450	500	0,215	0,265	3,10	3,80	7,80	9,50	
500	560	0,245	0,300	3,40	4,10	8,40	10,30	
560	630	0,275	0,340	3,80	4,65	9,50	11,60	
630	710	0,310	0,380	4,25	5,20	10,60	13,00	
710	800	0,350	0,425	4,75	5,80	11,90	14,50	
800	900	0,395	0,480	5,40	6,60	13,50	16,40	
900	1 000	0,440	0,535	6,00	7,30	15,00	18,30	
1 000	1 120	0,490	0,600	6,40	7,80	16,00	19,50	
1 120	1 250	0,550	0,670	7,10	8,70	17,80	21,70	
1 250	1 400	0,610	0,750	8,00	9,70	19,90	24,30	
1 400	1 600	0,700	0,850	9,10	11,10	22,70	27,70	
1 600	1 800	0,790	0,960	10,20	12,50	25,60	31,20	

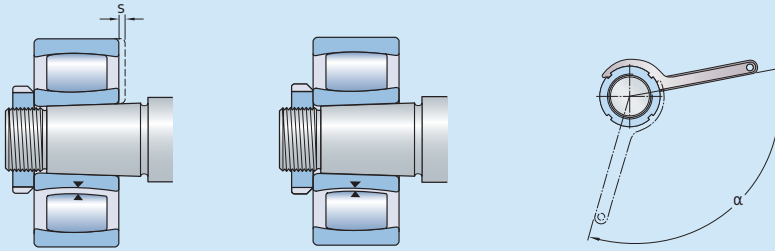
NOTE: Applying the recommended values prevents the inner ring from creeping, but does not ensure correct radial internal clearance in operation. Additional influences from the bearing housing fit and temperature differences between the inner ring and outer ring, must be considered carefully when selecting the bearing radial internal clearance class. For additional information, contact the SKF application engineering service.

Valid only for solid steel shafts and general applications.

¹⁾ Not valid for the SKF Drive-up Method.

²⁾ The listed values are to be used as guideline values only, as it is difficult to establish an exact starting position. Also the axial drive-up s differs slightly between the different bearings series.

Drive-up data for CARB toroidal roller bearings with a tapered bore



Bore diameter d		Reduction of radial internal clearance		Axial drive-up s ^{1),2)} Taper 1:12 Taper 1:30				Lock nut tightening angle ²⁾ Taper 1:12 α
over	incl.	min	max	min	max	min	max	degrees
mm		mm		mm				degrees
24	30	0,010	0,015	0,25	0,29	–	–	100
30	40	0,015	0,020	0,30	0,35	0,75	0,90	115
40	50	0,020	0,025	0,37	0,44	0,95	1,10	130
50	65	0,025	0,035	0,45	0,54	1,15	1,35	115
65	80	0,035	0,040	0,55	0,65	1,40	1,65	130
80	100	0,040	0,050	0,66	0,79	1,65	2,00	150
100	120	0,050	0,060	0,79	0,95	2,00	2,35	
120	140	0,060	0,075	0,93	1,10	2,30	2,80	
140	160	0,070	0,085	1,05	1,30	2,65	3,20	
160	180	0,080	0,095	1,20	1,45	3,00	3,60	
180	200	0,090	0,105	1,30	1,60	3,30	4,00	
200	225	0,100	0,120	1,45	1,80	3,70	4,45	
225	250	0,110	0,130	1,60	1,95	4,00	4,85	
250	280	0,120	0,150	1,80	2,15	4,50	5,40	
280	315	0,135	0,165	2,00	2,40	4,95	6,00	
315	355	0,150	0,180	2,15	2,65	5,40	6,60	
355	400	0,170	0,210	2,50	3,00	6,20	7,60	
400	450	0,195	0,235	2,80	3,40	7,00	8,50	
450	500	0,215	0,265	3,10	3,80	7,80	9,50	
500	560	0,245	0,300	3,40	4,10	8,40	10,30	
560	630	0,275	0,340	3,80	4,65	9,50	11,60	
630	710	0,310	0,380	4,25	5,20	10,60	13,00	
710	800	0,350	0,425	4,75	5,80	11,90	14,50	
800	900	0,395	0,480	5,40	6,60	13,50	16,40	
900	1 000	0,440	0,535	6,00	7,30	15,00	18,30	
1 000	1 120	0,490	0,600	6,40	7,80	16,00	19,50	
1 120	1 250	0,550	0,670	7,10	8,70	17,80	21,70	
1 250	1 400	0,610	0,750	8,00	9,70	19,90	24,30	
1 400	1 600	0,700	0,850	9,10	11,10	22,70	27,70	
1 600	1 800	0,790	0,960	10,20	12,50	25,60	31,20	

NOTE: Applying the recommended values prevents the inner ring from creeping, but does not ensure correct radial internal clearance in operation. Additional influences from the bearing housing fit and temperature differences between the inner ring and outer ring, must be considered carefully when selecting the bearing radial internal clearance class. For additional information, contact the SKF application engineering service.

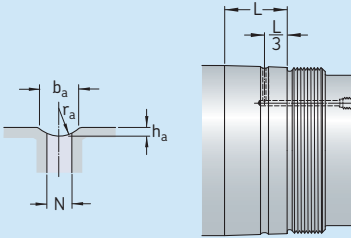
Valid only for solid steel shafts and general applications.

¹⁾ Not valid for the SKF Drive-up Method.

²⁾ The listed values are to be used as guideline values only, as it is difficult to establish an exact starting position. Also the axial drive-up s differs slightly between the different bearings series.

Appendix G-1

Recommended dimensions for oil supply ducts and distribution grooves

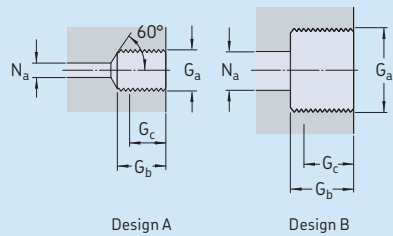


Seat diameter		Dimensions			
over	incl.	b_a	h_a	r_a	N
mm		mm			
–	100	3	0,5	2,5	2,5
100	150	4	0,8	3	3
150	200	4	0,8	3	3
200	250	5	1	4	4
250	300	5	1	4	4
300	400	6	1,25	4,5	5
400	500	7	1,5	5	5
500	650	8	1,5	6	6
650	800	10	2	7	7
800	1 000	12	2,5	8	8

L = width of bearing seat

Appendix G-2

Design and recommended dimensions for threaded holes for connecting oil supply



Thread	Design	Dimensions		
G_a		G_b	$G_c^{1)}$	N_a max
–	–	mm		
M 6	A	10	8	3
G 1/8	A	12	10	3
G 1/4	A	15	12	5
G 3/8	B	15	12	8
G 1/2	B	18	14	8
G 3/4	B	20	16	8

¹⁾ Effective threaded length

SKF Drive-up Method – guideline values for requisite oil pressure and axial displacement for mounting self-aligning ball bearings

Bearing designation	Starting position		Final position		Radial clearance reduction from zero position Δ_r	Hydraulic nut Designation	Piston area A_{ref}
	Requisite oil pressure $P_{ref}^{1)}$ for one sliding surface	two sliding surfaces	Axial displacement from starting position s_s one sliding surface	two sliding surfaces			
–	MPa		mm		mm	–	mm ²
Series 12							
1210 EKTN9	0,57	0,97	0,25	0,30	0,018	HMV 10E	2 900
1211 EKTN9	0,76	1,30	0,26	0,31	0,019	HMV 11E	3 150
1212 EKTN9	0,92	1,55	0,29	0,34	0,021	HMV 12E	3 300
1213 EKTN9	0,99	1,70	0,31	0,36	0,023	HMV 13E	3 600
1215 K	0,88	1,50	0,33	0,38	0,026	HMV 15E	4 000
1216 K	1,10	1,85	0,36	0,41	0,028	HMV 16E	4 200
1217 K	1,10	1,90	0,38	0,43	0,030	HMV 17E	4 400
1218 K	1,15	1,90	0,40	0,46	0,032	HMV 18E	4 700
1219 K	1,35	2,30	0,41	0,47	0,033	HMV 19E	4 900
1220 K	1,45	2,50	0,44	0,49	0,035	HMV 20E	5 100
1222 K	1,70	2,90	0,49	0,54	0,039	HMV 22E	5 600
1224 KM	1,55	2,70	0,50	0,56	0,042	HMV 24E	6 000
1226 KM	1,75	3,00	0,55	0,60	0,046	HMV 26E	6 400
Series 13							
1310 EKTN9	1,45	2,50	0,27	0,32	0,018	HMV 10E	2 900
1311 EKTN9	1,65	2,80	0,28	0,33	0,019	HMV 11E	3 150
1312 EKTN9	2,45	4,20	0,33	0,38	0,021	HMV 12E	3 300
1313 EKTN9	2,60	4,40	0,35	0,40	0,023	HMV 13E	3 600
1315 K	2,20	3,70	0,36	0,41	0,026	HMV 15E	4 000
1316 K	2,30	4,00	0,39	0,44	0,028	HMV 16E	4 200
1317 K	2,50	4,30	0,41	0,46	0,030	HMV 17E	4 400
1318 K	2,40	4,10	0,43	0,49	0,032	HMV 18E	4 700
1319 K	2,50	4,20	0,44	0,49	0,033	HMV 19E	4 900
1320 K	2,80	4,70	0,47	0,52	0,035	HMV 20E	5 100
1322 KM	3,40	5,70	0,53	0,58	0,039	HMV 22E	5 600
Series 22							
2210 EKTN9	0,61	1,05	0,24	0,30	0,018	HMV 10E	2 900
2211 EKTN9	0,68	1,15	0,25	0,30	0,019	HMV 11E	3 150
2212 EKTN9	0,84	1,45	0,27	0,33	0,021	HMV 12E	3 300
2213 EKTN9	0,91	1,55	0,30	0,35	0,023	HMV 13E	3 600
2215 EKTN9	0,88	1,50	0,32	0,37	0,026	HMV 15E	4 000
2216 EKTN9	1,05	1,80	0,35	0,40	0,028	HMV 16E	4 200
2217 K	1,25	2,10	0,37	0,43	0,030	HMV 17E	4 400
2218 K	1,40	2,30	0,40	0,45	0,032	HMV 18E	4 700
2219 KM	1,50	2,60	0,40	0,46	0,033	HMV 19E	4 900
2220 K	1,60	2,70	0,43	0,48	0,035	HMV 20E	5 100
2222 KM	1,85	3,10	0,47	0,52	0,039	HMV 22E	5 600
Series 23							
2310 K	1,30	2,20	0,25	0,30	0,018	HMV 10E	2 900
2311 K	1,55	2,60	0,26	0,31	0,019	HMV 11E	3 150
2312 K	1,65	2,80	0,28	0,33	0,021	HMV 12E	3 300
2313 K	2,00	3,40	0,31	0,36	0,023	HMV 13E	3 600
2315 K	2,30	3,90	0,34	0,39	0,026	HMV15E	4 000
2316 K	2,40	4,10	0,36	0,41	0,028	HMV 16E	4 200
2317 K	2,60	4,50	0,39	0,44	0,030	HMV 17E	4 400
2318 K	2,80	4,70	0,41	0,46	0,032	HMV 18E	4 700
2319 KM	2,90	4,90	0,42	0,47	0,033	HMV 19E	4 900
2320 K	3,30	5,60	0,44	0,49	0,035	HMV 20E	5 100

¹⁾ The values listed are valid for the hydraulic nut indicated. If another hydraulic nut is used, the oil pressure needs to be adjusted (→ SKF Drive-up Method, page 57).

SKF Drive-up Method – guideline values for requisite oil pressure and axial displacement for mounting spherical roller bearings

Bearing designation ¹⁾	Starting position		Final position		Radial clearance reduction from zero position Δ_r	Hydraulic nut Designation	Piston area A_{ref}
	Requisite oil pressure $P_{ref}^{(2)}$ for one sliding surface	two sliding surfaces	Axial displacement from starting position s_a for one sliding surface	two sliding surfaces			
–	MPa		mm		mm	–	mm ²
Series 213							
21310 EK	1,90	3,20	0,40	0,47	0,023	HMV 10E	2 900
21311 EK	1,40	2,40	0,40	0,46	0,025	HMV 11E	3 150
21312 EK	2,40	4,10	0,45	0,52	0,027	HMV 12E	3 300
21313 EK	2,50	4,30	0,47	0,55	0,029	HMV 13E	3 600
21314 EK	2,70	4,50	0,52	0,59	0,032	HMV 14E	3 800
21315 EK	2,20	3,70	0,51	0,58	0,034	HMV 15E	4 000
21316 EK	2,20	3,80	0,53	0,60	0,036	HMV 16E	4 200
21317 EK	1,75	3,00	0,53	0,60	0,038	HMV 17E	4 400
21318 EK	1,85	3,20	0,57	0,64	0,041	HMV 18E	4 700
21319 EK	1,90	3,30	0,59	0,66	0,043	HMV 19E	4 900
21320 EK	1,50	2,50	0,58	0,65	0,045	HMV 20E	5 100
Series 222							
22210 EK	0,75	1,25	0,34	0,42	0,023	HMV 10E	2 900
22211 EK	0,70	1,25	0,36	0,43	0,025	HMV 11E	3 150
22212 EK	0,85	1,50	0,40	0,45	0,027	HMV 12E	3 300
22213 EK	0,95	1,65	0,43	0,47	0,029	HMV 13E	3 600
22214 EK	0,95	1,60	0,44	0,51	0,032	HMV 14E	3 800
22215 EK	0,90	1,50	0,46	0,53	0,034	HMV 15E	4 000
22216 EK	1,00	1,70	0,48	0,55	0,036	HMV 16E	4 200
22217 EK	1,15	2,00	0,50	0,58	0,038	HMV 17E	4 400
22218 EK	1,20	2,10	0,54	0,61	0,041	HMV 18E	4 700
22219 EK	1,35	2,30	0,57	0,64	0,043	HMV 19E	4 900
22220 EK	1,45	2,50	0,59	0,66	0,045	HMV 20E	5 100
22222 EK	1,75	3,00	0,65	0,72	0,050	HMV 22E	5 600
22224 EK	1,85	3,10	0,68	0,76	0,054	HMV 24E	6 000
22226 EK	1,95	3,40	0,74	0,81	0,059	HMV 26E	6 400
22228 CCK/W33	2,30	4,00	0,80	0,86	0,063	HMV 28E	6 800
22230 CCK/W33	2,50	4,30	0,85	0,92	0,068	HMV 30E	7 500
22232 CCK/W33	2,60	4,40	0,91	0,97	0,072	HMV 32E	8 600
22234 CCK/W33	2,80	4,70	0,97	1,02	0,077	HMV 34E	9 400
22236 CCK/W33	2,50	4,30	1,01	1,07	0,081	HMV 36E	10 300
22238 CCK/W33	2,60	4,40	1,06	1,13	0,086	HMV 38E	11 500
22240 CCK/W33	2,70	4,60	1,12	1,17	0,090	HMV 40E	12 500
22244 CCK/W33	2,90	5,00	1,22	1,28	0,099	HMV 44E	14 400
22248 CCK/W33	3,30	5,60	1,34	1,40	0,108	HMV 48E	16 500
22252 CACK/W33	3,20	5,50	1,43	1,49	0,117	HMV 52E	18 800
22256 CACK/W33	3,00	5,00	1,52	1,59	0,126	HMV 56E	21 100
22260 CACK/W33	2,90	4,90	1,62	1,68	0,135	HMV 60E	23 600
22264 CACK/W33	3,10	5,20	1,73	1,79	0,144	HMV 64E	26 300
22272 CAK/W33	3,60	6,10	1,96	2,02	0,162	HMV 72E	31 300

¹⁾ For large spherical roller bearings not listed in the table, contact the SKF application engineering service.

²⁾ The values listed are valid for the hydraulic nut indicated. If another hydraulic nut is used, the oil pressure needs to be adjusted (→ SKF Drive-up Method, page 57).

SKF Drive-up Method – guideline values for requisite oil pressure and axial displacement for mounting spherical roller bearings

Bearing designation ¹⁾	Starting position		Final position		Radial clearance reduction from zero position Δ_r	Hydraulic nut Designation	Piston area A_{ref}
	Requisite oil pressure P_{ref} ²⁾ for one sliding surface	two sliding surfaces	Axial displacement from starting position s_s for one sliding surface	two sliding surfaces			
–	MPa		mm		–	mm ²	
Series 223							
22310 EK	1,60	2,80	0,35	0,43	0,023	HMV 10E	2 900
22311 EK	2,00	3,40	0,38	0,46	0,025	HMV 11E	3 150
22312 EK	2,40	4,10	0,41	0,48	0,027	HMV 12E	3 300
22313 EK	2,10	3,60	0,42	0,49	0,029	HMV 13E	3 600
22314 EK	2,60	4,40	0,47	0,55	0,032	HMV 14E	3 800
22315 EK	2,30	4,00	0,48	0,55	0,034	HMV 15E	4 000
22316 EK	2,40	4,10	0,50	0,57	0,036	HMV 16E	4 200
22317 EK	3,00	5,00	0,54	0,61	0,038	HMV 17E	4 400
22318 EK	3,00	5,10	0,57	0,65	0,041	HMV 18E	4 700
22319 EK	3,00	5,20	0,59	0,65	0,043	HMV 19E	4 900
22320 EK	4,10	7,00	0,64	0,71	0,045	HMV 20E	5 100
22322 EK	4,50	7,70	0,70	0,78	0,050	HMV 22E	5 600
22324 CCK/W33	4,40	7,50	0,74	0,81	0,054	HMV 24E	6 000
22326 CCK/W33	4,70	8,10	0,80	0,87	0,059	HMV 26E	6 400
22328 CCK/W33	5,00	8,60	0,84	0,91	0,063	HMV 28E	6 800
22330 CCK/W33	5,30	9,00	0,90	0,98	0,068	HMV 30E	7 500
22332 CCK/W33	5,20	8,80	0,95	1,02	0,072	HMV 32E	8 600
22334 CCK/W33	5,20	8,90	0,99	1,06	0,077	HMV 34E	9 400
22336 CCK/W33	5,10	8,80	1,05	1,12	0,081	HMV 36E	10 300
22338 CCK/W33	5,10	8,70	1,11	1,18	0,086	HMV 38E	11 500
22340 CCK/W33	5,10	8,80	1,16	1,23	0,090	HMV 40E	12 500
22344 CCK/W33	5,60	9,50	1,29	1,36	0,099	HMV 44E	14 400
22348 CCK/W33	5,60	9,50	1,39	1,46	0,108	HMV 48E	16 500
22352 CCK/W33	5,60	9,60	1,50	1,57	0,117	HMV 52E	18 800
22356 CCK/W33	5,70	9,70	1,61	1,68	0,126	HMV 56E	21 100
Series 230							
23022 CCK/W33	1,10	1,85	0,62	0,69	0,050	HMV 22E	5 600
23024 CCK/W33	1,05	1,75	0,66	0,73	0,054	HMV 24E	6 000
23026 CCK/W33	1,25	2,20	0,72	0,83	0,059	HMV 26E	6 400
23028 CCK/W33	1,20	2,10	0,76	0,89	0,063	HMV 28E	6 800
23030 CCK/W33	1,25	2,10	0,81	0,88	0,068	HMV 30E	7 500
23032 CCK/W33	1,25	2,10	0,85	0,92	0,072	HMV 32E	8 600
23034 CCK/W33	1,35	2,30	0,89	0,96	0,077	HMV 34E	9 400
23036 CCK/W33	1,50	2,60	0,95	1,03	0,081	HMV 36E	10 300
23038 CCK/W33	1,50	2,50	1,01	1,09	0,086	HMV 38E	11 500
23040 CCK/W33	1,65	2,80	1,06	1,13	0,090	HMV 40E	12 500
23044 CCK/W33	1,65	2,90	1,15	1,23	0,099	HMV 44E	14 400
23048 CCK/W33	1,50	2,50	1,24	1,31	0,108	HMV 48E	16 500
23052 CCK/W33	1,70	2,90	1,35	1,42	0,117	HMV 52E	18 800
23056 CCK/W33	1,55	2,70	1,44	1,51	0,126	HMV 56E	21 100
23060 CCK/W33	1,75	3,00	1,54	1,61	0,135	HMV 60E	23 600
23064 CCK/W33	1,60	2,70	1,63	1,70	0,144	HMV 64E	26 300
23068 CCK/W33	1,85	3,10	1,74	1,81	0,153	HMV 68E	28 400
23072 CCK/W33	1,65	2,80	1,82	1,89	0,162	HMV 72E	31 300
23076 CCK/W33	1,60	2,70	1,91	1,98	0,171	HMV 76E	33 500
23080 CCK/W33	1,75	3,00	2,02	2,09	0,180	HMV 80E	36 700

¹⁾ For large spherical roller bearings not listed in the table, contact the SKF application engineering service.

²⁾ The values listed are valid for the hydraulic nut indicated. If another hydraulic nut is used, the oil pressure needs to be adjusted (→ SKF Drive-up Method, page 57).

SKF Drive-up Method – guideline values for requisite oil pressure and axial displacement for mounting spherical roller bearings

Bearing designation ¹⁾	Starting position		Final position		Radial clearance reduction from zero position Δ_r	Hydraulic nut Designation	Piston area A_{ref}
	Requisite oil pressure for one sliding surface	Requisite oil pressure P_{ref} ²⁾ for two sliding surfaces	Axial displacement from starting position s_s for one sliding surface	Axial displacement from starting position s_s for two sliding surfaces			
–	MPa		mm		–	mm ²	
Series 231							
23120 CCK/W33	1,40	2,40	0,57	0,64	0,045	HMV 20E	5 100
23122 CCK/W33	1,45	2,50	0,63	0,70	0,050	HMV 22E	5 600
23124 CCK/W33	1,75	3,00	0,67	0,75	0,054	HMV 24E	6 000
23126 CCK/W33	1,65	2,80	0,72	0,80	0,059	HMV 26E	6 400
23128 CCK/W33	1,70	2,90	0,76	0,83	0,063	HMV 28E	6 800
23130 CCK/W33	2,20	3,80	0,83	0,90	0,068	HMV 30E	7 500
23132 CCK/W33	2,30	3,90	0,87	0,95	0,072	HMV 32E	8 600
23134 CCK/W33	2,10	3,70	0,91	0,98	0,077	HMV 34E	9 400
23136 CCK/W33	2,30	4,00	0,97	1,04	0,081	HMV 36E	10 300
23138 CCK/W33	2,50	4,30	1,04	1,11	0,086	HMV 38E	11 500
23140 CCK/W33	2,60	4,50	1,08	1,15	0,090	HMV 40E	12 500
23144 CCK/W33	2,70	4,60	1,18	1,25	0,099	HMV 44E	14 400
23148 CCK/W33	2,60	4,50	1,27	1,35	0,108	HMV 48E	16 500
23152 CCK/W33	2,90	4,90	1,38	1,45	0,117	HMV 52E	18 800
23156 CCK/W33	2,60	4,40	1,47	1,54	0,126	HMV 56E	21 100
23160 CCK/W33	2,80	4,80	1,57	1,64	0,135	HMV 60E	23 600
23164 CCK/W33	3,10	5,30	1,68	1,75	0,144	HMV 64E	26 300
23168 CCK/W33	3,40	5,80	1,79	1,86	0,153	HMV 68E	28 400
23172 CCK/W33	3,30	5,60	1,90	1,96	0,162	HMV 72E	31 300
23176 CAK/W33	2,90	4,90	1,96	2,03	0,171	HMV 76E	33 500
23180 CAK/W33	2,80	4,70	2,05	2,12	0,180	HMV 80E	36 700
Series 232							
23218 CCK/W33	1,70	2,90	0,54	0,62	0,041	HMV 18E	4 700
23220 CCK/W33	1,90	3,30	0,58	0,66	0,045	HMV 20E	5 100
23222 CCK/W33	2,40	4,00	0,65	0,72	0,050	HMV 22E	5 600
23224 CCK/W33	2,50	4,30	0,69	0,76	0,054	HMV 24E	6 000
23226 CCK/W33	2,60	4,40	0,74	0,81	0,059	HMV 26E	6 400
23228 CCK/W33	3,00	5,20	0,79	0,86	0,063	HMV 28E	6 800
23230 CCK/W33	3,1	5,30	0,85	0,92	0,068	HMV 30E	7 500
23232 CCK/W33	3,30	5,60	0,90	0,97	0,072	HMV 32E	8 600
23234 CCK/W33	3,40	5,90	0,94	1,01	0,077	HMV 34E	9 400
23236 CCK/W33	3,20	5,40	0,99	1,06	0,081	HMV 36E	10 300
23238 CCK/W33	3,30	5,60	1,05	1,12	0,086	HMV 38E	11 500
23240 CCK/W33	3,50	5,90	1,10	1,17	0,090	HMV 40E	12 500
23244 CCK/W33	3,80	6,50	1,21	1,28	0,099	HMV 44E	14 400
23248 CCK/W33	4,30	7,40	1,32	1,40	0,108	HMV 48E	16 500
23252 CACK/W33	4,60	7,80	1,43	1,51	0,117	HMV 52E	18 800
23256 CACK/W33	4,10	7,00	1,52	1,59	0,126	HMV 56E	21 100
23260 CACK/W33	4,30	7,40	1,63	1,70	0,135	HMV 60E	23 600
23264 CACK/W33	4,70	8,00	1,74	1,81	0,144	HMV 64E	26 300
23268 CAK/W33	5,00	8,50	1,85	1,92	0,153	HMV 68E	28 400
23272 CAK/W33	4,70	8,00	1,93	2,00	0,162	HMV 72E	31 300
23276 CAK/W33	4,70	8,10	2,03	2,11	0,171	HMV 76E	33 500
23280 CAK/W33	5,00	8,50	2,15	2,22	0,180	HMV 80E	36 700

¹⁾ For large spherical roller bearings not listed in the table, contact the SKF application engineering service.

²⁾ The values listed are valid for the hydraulic nut indicated. If another hydraulic nut is used, the oil pressure needs to be adjusted (→ SKF Drive-up Method, page 57).

SKF Drive-up Method – guideline values for requisite oil pressure and axial displacement for mounting spherical roller bearings

Bearing designation ¹⁾	Starting position		Final position		Radial clearance reduction from zero position Δ_r	Hydraulic nut Designation	Piston area A_{ref}
	Requisite oil pressure $P_{ref}^{(2)}$ for one sliding surface	two sliding surfaces	Axial displacement from starting position s_s for one sliding surface	two sliding surfaces			
–	MPa		mm		–	mm ²	
Series 239							
23936 CCK/W33	0,84	1,45	0,93	1,00	0,081	HMV 36E	10 300
23938 CCK/W33	0,72	1,20	0,98	1,05	0,086	HMV 38E	11 500
23940 CCK/W33	0,89	1,55	1,03	1,10	0,090	HMV 40E	12 500
23944 CCK/W33	0,75	1,30	1,11	1,19	0,099	HMV 44E	14 400
23948 CCK/W33	0,64	1,10	1,20	1,27	0,108	HMV 48E	16 500
23952 CCK/W33	0,91	1,55	1,31	1,38	0,117	HMV 52E	18 800
23956 CCK/W33	0,82	1,40	1,41	1,47	0,126	HMV 56E	21 100
23960 CCK/W33	1,05	1,80	1,51	1,58	0,135	HMV 60E	23 600
23964 CCK/W33	0,96	1,65	1,60	1,67	0,144	HMV 64E	26 300
23968 CCK/W33	0,89	1,50	1,68	1,75	0,153	HMV 68E	28 400
23972 CCK/W33	0,81	1,40	1,77	1,84	0,162	HMV 72E	31 300
23976 CCK/W33	1,05	1,80	1,88	1,95	0,171	HMV 76E	33 500
23980 CCK/W33	0,93	1,60	1,96	2,03	0,180	HMV 80E	36 700
Series 240							
24024 CCK30/W33	1,10	2,00	1,64	1,82	0,054	HMV 24E	6 000
24026 CCK30/W33	1,40	2,60	1,80	1,98	0,059	HMV 26E	6 400
24028 CCK30/W33	1,30	2,40	1,88	2,06	0,063	HMV 28E	6 800
24030 CCK30/W33	1,35	2,50	2,02	2,20	0,068	HMV 30E	7 500
24032 CCK30/W33	1,30	2,50	2,12	2,30	0,072	HMV 32E	8 600
24034 CCK30/W33	1,50	2,80	2,23	2,41	0,077	HMV 34E	9 400
24036 CCK30/W33	1,80	3,30	2,40	2,58	0,081	HMV 36E	10 300
24038 CCK30/W33	1,55	2,90	2,52	2,70	0,086	HMV 38E	11 500
24040 CCK30/W33	1,75	3,20	2,64	2,82	0,090	HMV 40E	12 500
24044 CCK30/W33	1,75	3,20	2,88	3,06	0,099	HMV 44E	14 400
24048 CCK30/W33	1,50	2,80	3,09	3,27	0,108	HMV 48E	16 500
24052 CCK30/W33	1,90	3,50	3,37	3,55	0,117	HMV 52E	18 800
24056 CCK30/W33	1,65	3,10	3,58	3,76	0,126	HMV 56E	21 100
24060 CCK30/W33	1,90	3,50	3,84	4,02	0,135	HMV 60E	23 600
24064 CCK30/W33	1,80	3,30	4,08	4,26	0,144	HMV 64E	26 300
24068 CCK30/W33	2,00	3,80	4,34	4,52	0,153	HMV 68E	28 400
24072 CCK30/W33	1,90	3,40	4,55	4,73	0,162	HMV 72E	31 300
24076 CCK30/W33	1,80	3,30	4,78	4,96	0,171	HMV 76E	33 500
24080 ECCK30/W33	1,95	3,70	5,04	5,22	0,180	HMV 80E	36 700

¹⁾ For large spherical roller bearings not listed in the table, contact the SKF application engineering service.

²⁾ The values listed are valid for the hydraulic nut indicated. If another hydraulic nut is used, the oil pressure needs to be adjusted (→ SKF Drive-up Method, page 57).

SKF Drive-up Method – guideline values for requisite oil pressure and axial displacement for mounting spherical roller bearings

Bearing designation ¹⁾	Starting position		Final position		Radial clearance reduction from zero position Δ_r	Hydraulic nut Designation	Piston area A_{ref}
	Requisite oil pressure P_{ref} ²⁾ for one sliding surface	Requisite oil pressure P_{ref} ²⁾ for two sliding surfaces	Axial displacement from starting position s_e for one sliding surface	Axial displacement from starting position s_e for two sliding surfaces			
–	MPa		mm		–	mm ²	
Series 241							
24122 CCK30/W33	1,55	2,90	1,58	1,76	0,050	HMV 22E	5 600
24124 CCK30/W33	1,95	3,60	1,69	1,87	0,054	HMV 24E	6 000
24126 CCK30/W33	1,85	3,50	1,83	2,01	0,059	HMV 26E	6 400
24128 CCK30/W33	1,90	3,50	1,92	2,10	0,063	HMV 28E	6 800
24130 CCK30/W33	2,40	4,40	2,08	2,26	0,068	HMV 30E	7 500
24132 CCK30/W33	2,60	4,70	2,21	2,39	0,072	HMV 32E	8 600
24134 CCK30/W33	2,20	4,00	2,28	2,46	0,077	HMV 34E	9 400
24136 CCK30/W33	2,50	4,60	2,44	2,62	0,081	HMV 36E	10 300
24138 CCK30/W33	2,70	4,90	2,60	2,79	0,086	HMV 38E	11 500
24140 CCK30/W33	2,80	5,20	2,71	2,89	0,090	HMV 40E	12 500
24144 CCK30/W33	2,80	5,20	2,96	3,14	0,099	HMV 44E	14 400
24148 CCK30/W33	2,80	5,30	3,21	3,39	0,108	HMV 48E	16 500
24152 CCK30/W33	3,10	5,70	3,47	3,65	0,117	HMV 52E	18 800
24156 CCK30/W33	2,80	5,10	3,69	3,87	0,126	HMV 56E	21 100
24160 CCK30/W33	3,10	5,70	3,96	4,14	0,135	HMV 60E	23 600
24164 CCK30/W33	3,40	6,30	4,24	4,42	0,144	HMV 64E	26 300
24168 ECAK30/W33	3,60	6,70	4,48	4,66	0,153	HMV 68E	28 400
24172 ECCK30J/W33	3,30	6,10	4,70	4,88	0,162	HMV 72E	31 300
24176 ECAK30/W33	3,00	5,60	4,91	5,09	0,171	HMV 76E	33 500
24180 ECAK30/W33	2,90	5,40	5,14	5,32	0,180	HMV 80E	36 700
Series BS2-							
BS2-2210-2CSK/VT143	0,83	1,40	0,34	0,41	(0,023)	HMV 10E	2 900
BS2-2211-2CSK/VT143	0,87	1,50	0,36	0,43	(0,025)	HMV 11E	3 150
BS2-2212-2CSK/VT143	1,15	1,95	0,38	0,46	(0,027)	HMV 12E	3 300
BS2-2213-2CSK/VT143	1,40	2,40	0,41	0,48	(0,029)	HMV 13E	3 600
BS2-2214-2CSK/VT143	1,10	1,90	0,44	0,51	(0,032)	HMV 14E	3 800
BS2-2215-2CSK/VT143	1,05	1,75	0,45	0,53	(0,034)	HMV 15E	4 000
BS2-2216-2CSK/VT143	1,20	2,00	0,48	0,55	(0,036)	HMV 1 E	4 200
BS2-2217-2CSK/VT143	1,40	2,40	0,50	0,57	(0,038)	HMV 17E	4 400
BS2-2218-2CSK/VT143	1,40	2,40	0,54	0,61	(0,041)	HMV 18E	4 700
BS2-2219-2CS5K/VT143	1,60	2,70	0,56	0,63	(0,043)	HMV 19E	4 900
BS2-2220-2CS5K/VT143	1,70	2,90	0,58	0,65	(0,045)	HMV 20E	5 100
BS2-2222-2CS5K/VT143	2,00	2,60	0,64	0,65	(0,050)	HMV 22E	5 600
BS2-2224-2CS5K/VT143	2,10	3,60	0,68	0,75	(0,054)	HMV 24E	6 000
BS2-2226-2CS5K/VT143	2,20	3,80	0,74	0,81	(0,059)	HMV 26E	6 400

¹⁾ For large spherical roller bearings not listed in the table, contact the SKF application engineering service.

²⁾ The values listed are valid for the hydraulic nut indicated. If another hydraulic nut is used, the oil pressure needs to be adjusted (→ SKF Drive-up Method, page 57).

SKF Drive-up Method - guideline values for requisite oil pressure and axial displacement for mounting CARB toroidal roller bearings

Bearing designation ¹⁾	Starting position		Final position		Radial clearance reduction from zero position Δ_r	Hydraulic nut Designation	Piston area A_{ref}
	Requisite oil pressure $P_{ref}^{(2)}$ for one sliding surface	two sliding surfaces	Axial displacement from starting position s_s for one sliding surface	two sliding surfaces			
–	MPa		mm		–	mm ²	
Series C 22							
C 2210 KTN9	0,67	1,15	0,34	0,41	0,023	HMV 10E	2 900
C 2211 KTN9	0,57	0,98	0,35	0,42	0,025	HMV 11E	3 150
C 2212 KTN9	1,10	1,85	0,39	0,47	0,027	HMV 12E	3 300
C 2213 KTN9	0,82	1,40	0,40	0,47	0,029	HMV 13E	3 600
C 2214 KTN9	0,76	1,30	0,43	0,50	0,032	HMV 14E	3 800
C 2215 K	0,70	1,20	0,45	0,52	0,034	HMV 15E	4 000
C 2216 K	1,05	1,75	0,48	0,55	0,036	HMV 16E	4 200
C 2217 K	1,10	1,90	0,50	0,57	0,038	HMV 17E	4 400
C 2218 K	1,35	2,30	0,55	0,62	0,041	HMV 18E	4 700
C 2219 K	1,00	1,70	0,54	0,62	0,043	HMV 19E	4 900
C 2220 K	1,10	1,90	0,57	0,64	0,045	HMV 20E	5 100
C 2222 K	1,50	2,50	0,63	0,71	0,050	HMV 22E	5 600
C 2224 K	1,60	2,70	0,67	0,74	0,054	HMV 24E	6 000
C 2226 K	1,45	2,50	0,71	0,79	0,059	HMV 26E	6 400
C 2228 K	2,40	4,00	0,79	0,86	0,063	HMV 28E	6 800
C 2230 K	1,80	3,10	0,82	0,89	0,068	HMV 30E	7 500
C 2234 K	2,60	4,40	0,94	1,01	0,076	HMV 34E	9 400
C 2238 K	1,80	3,00	1,01	1,08	0,086	HMV 38E	11 500
C 2244 K	1,95	3,30	1,15	1,22	0,099	HMV 44E	14 400
Series C 23							
C 2314 K	2,00	3,40	0,46	0,53	0,032	HMV 14E	3 800
C 2315 K	2,30	3,80	0,48	0,55	0,034	HMV 15E	4 000
C 2316 K	2,10	3,60	0,49	0,56	0,036	HMV 16E	4 200
C 2317 K	2,40	4,10	0,52	0,59	0,038	HMV 17E	4 400
C 2318 K	2,90	4,90	0,57	0,64	0,041	HMV 18E	4 700
C 2319 K	2,20	3,80	0,57	0,64	0,043	HMV 19E	4 900
C 2320 K	2,60	4,40	0,59	0,66	0,045	HMV 20E	5 100
Series C 30							
C 3022 K	0,97	1,65	0,62	0,69	0,050	HMV 22E	5 600
C 3024 K	0,92	1,60	0,65	0,72	0,054	HMV 24E	6 000
C 3026 K	1,25	2,10	0,72	0,79	0,059	HMV 26E	6 400
C 3028 K	1,25	2,10	0,76	0,83	0,063	HMV 28E	6 800
C 3030 KMB	1,00	1,75	0,80	0,87	0,068	HMV 30E	7 500
C 3032 K	1,35	2,30	0,86	0,93	0,072	HMV 32E	8 600
C 3034 K	1,50	2,60	0,90	0,98	0,076	HMV 34E	9 400
C 3036 K	1,45	2,40	0,95	1,02	0,081	HMV 36E	10 300
C 3038 K	1,60	2,70	1,02	1,09	0,086	HMV 38E	11 500
C 3040 K	1,60	2,80	1,06	1,13	0,090	HMV 40E	12 500
C 3044 K	1,60	2,70	1,15	1,22	0,099	HMV 44E	14 400
C 3048 K	1,35	2,30	1,23	1,30	0,108	HMV 48E	16 500
C 3052 K	1,80	3,00	1,35	1,43	0,117	HMV 52E	18 800
C 3056 K	1,70	2,90	1,45	1,52	0,126	HMV 56E	21 100
C 3060 KM	1,85	3,20	1,55	1,62	0,135	HMV 60E	23 600
C 3064 KM	1,80	3,10	1,65	1,72	0,144	HMV 64E	26 300
C 3068 KM	2,00	3,50	1,76	1,83	0,153	HMV 68E	28 400
C 3072 KM	1,65	2,80	1,82	1,89	0,162	HMV 72E	31 300
C 3076 KM	1,35	2,30	1,88	1,95	0,171	HMV 76E	33 500
C 3080 KM	1,55	2,60	2,00	2,06	0,180	HMV 80E	36 700

¹⁾ For CARB toroidal roller bearings not listed in the table, contact the SKF application engineering service.

²⁾ The values listed are valid for the hydraulic nut indicated. If another hydraulic nut is used, the oil pressure needs to be adjusted (→ SKF Drive-up Method, page 57).

SKF Drive-up Method - guideline values for requisite oil pressure and axial displacement for mounting CARB toroidal roller bearings

Bearing designation ¹⁾	Starting position		Final position		Radial clearance reduction from zero position Δ_r	Hydraulic nut Designation	Piston area A_{ref}
	Requisite oil pressure P_{ref} ²⁾ for one sliding surface	for two sliding surfaces	Axial displacement from starting position s_e for one sliding surface	for two sliding surfaces			
–	MPa		mm		–	mm ²	
Series C 31							
C 3130 K	2,40	4,10	0,84	0,91	0,068	HMV 30E	7 500
C 3132 K	2,10	3,50	0,87	0,94	0,072	HMV 32E	8 600
C 3134 K	1,85	3,10	0,90	0,97	0,076	HMV 34E	9 400
C 3136 K	1,70	2,90	0,94	1,01	0,081	HMV 36E	10 300
C 3138 K	2,30	3,90	1,02	1,10	0,086	HMV 38E	11 500
C 3140 K	2,70	4,60	1,08	1,16	0,090	HMV 40E	12 500
C 3144 K	2,80	4,70	1,18	1,26	0,099	HMV 44E	14 400
C 3148 K	2,00	3,40	1,24	1,31	0,108	HMV 48E	16 500
C 3152 K	2,80	4,70	1,37	1,44	0,117	HMV 52E	18 800
C 3156 K	2,60	4,50	1,47	1,54	0,126	HMV 56E	21 100
C 3160 K	2,80	4,80	1,57	1,64	0,135	HMV 60E	23 600
C 3164 KM	2,10	3,60	1,61	1,68	0,144	HMV 64E	26 300
C 3168 KM	2,80	4,80	1,75	1,82	0,153	HMV 68E	28 400
C 3172 KM	2,50	4,20	1,83	1,90	0,162	HMV 72E	31 300
C 3176 KM	2,60	4,40	1,93	2,01	0,171	HMV 76E	33 500
C 3180 KM	3,30	5,70	2,10	2,17	0,180	HMV 80E	36 700
Series C 32							
C 3224 K	2,50	4,20	0,69	0,76	0,054	HMV 24E	6 000
C 3232 K	2,70	4,60	0,87	0,94	0,072	HMV 32E	8 600
C 3236 K	3,70	6,30	1,01	1,09	0,081	HMV 36E	10 300
Series C 40							
C 4010 K30TN9	0,41	0,77	0,80	0,99	0,023	HMV 10E	2 900
C 4013 K30V	0,48	0,89	0,95	1,12	0,029	HMV 13E	3 600
C 4015 K30V	0,69	1,30	1,10	1,29	0,034	HMV 15E	4 000
C 4020 K30V	0,71	1,30	1,37	1,55	0,045	HMV 20E	5 100
C 4022 K30MB	0,87	1,60	1,51	1,69	0,050	HMV 22E	5 600
C 4024 K30V	1,15	2,20	1,65	1,84	0,054	HMV 24E	6 000
C 4026 K30	1,20	2,20	1,77	1,95	0,059	HMV 26E	6 400
C 4028 K30V	1,20	2,30	1,88	2,06	0,063	HMV 28E	6 800
C 4030 K30V	1,35	2,50	2,02	2,2	0,068	HMV 30E	7 500
C 4032 K30	1,05	1,95	2,08	2,26	0,072	HMV 32E	8 600
C 4034 K30V	1,35	2,50	2,21	2,39	0,076	HMV 34E	9 400
C 4036 K30V	1,20	2,20	2,31	2,49	0,081	HMV 36E	10 300
C 4038 K30V	1,50	2,80	2,51	2,69	0,086	HMV 38E	11 500
C 4040 K30V	1,35	2,50	2,58	2,76	0,090	HMV 40E	12 500
C 4044 K30V	1,40	2,60	2,82	3,00	0,099	HMV 44E	14 400
C 4060 K30M	1,35	2,50	3,72	3,90	0,135	HMV 60E	23 600
series C 41							
C 4120 K30V/VE240	1,40	2,60	1,43	1,61	0,045	HMV 20E	5 100
C 4122 K30V	1,60	3,00	1,58	1,76	0,050	HMV 22E	5 600
C 4124 K30V	1,45	2,70	1,64	1,82	0,054	HMV 24E	6 000
C 4126 K30V/VE240	1,70	3,10	1,81	1,99	0,059	HMV 26E	6 400
C 4128 K30V/VE240	2,00	3,70	1,93	2,11	0,063	HMV 28E	6 800
C 4130 K30V	2,20	4,00	2,06	2,24	0,068	HMV 30E	7 500
C 4132 K30V	2,10	3,90	2,16	2,34	0,072	HMV 32E	8 600
C 4134 K30V	1,90	3,50	2,24	2,42	0,076	HMV 34E	9 400
C 4136 K30V	1,95	3,60	2,38	2,56	0,081	HMV 36E	10 300
C 4138 K30V	2,00	3,70	2,52	2,70	0,086	HMV 38E	11 500

¹⁾ For CARB toroidal roller bearings not listed in the table, contact the SKF application engineering service.

²⁾ The values listed are valid for the hydraulic nut indicated. If another hydraulic nut is used, the oil pressure needs to be adjusted (→ SKF Drive-up Method, page 57).

Viscosity equivalents

Comparison of various viscosity classification methods

Kinematic viscosities

mm²/s at 40 °C (105 °F)
mm²/s at 100 °C (210 °F)

ISO VG

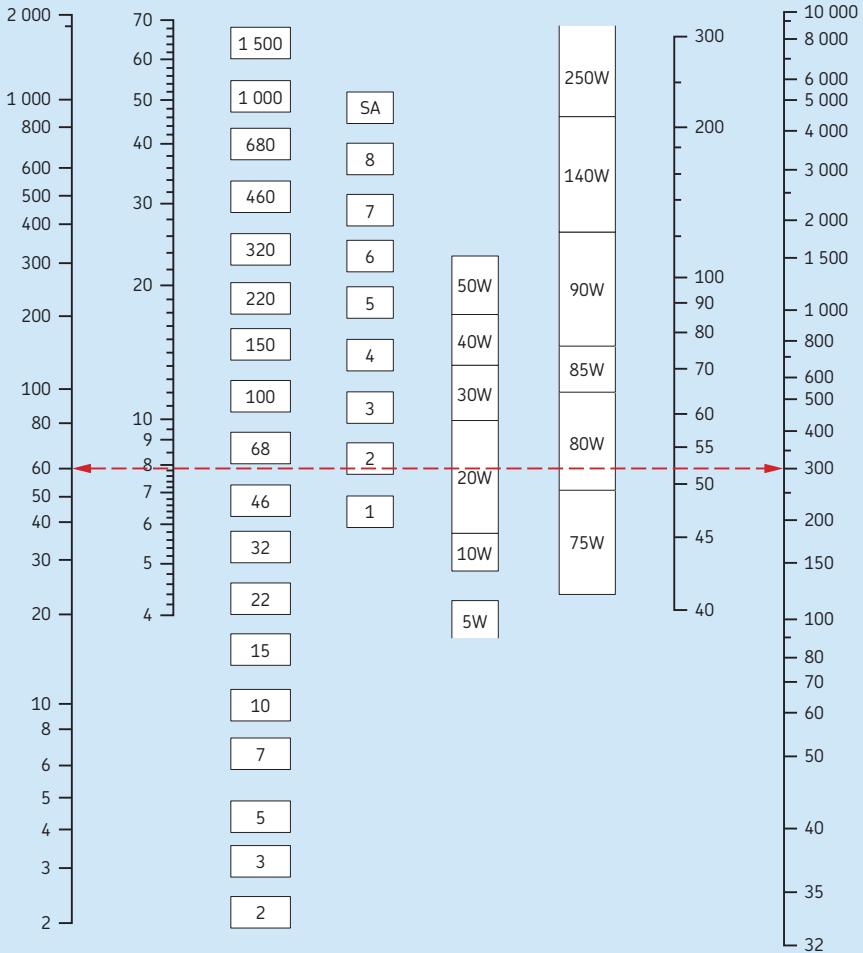
AGMA grades

SAE grades crankcase oils

SAE grades gear oils

Saybolt viscosities

SUS/210 °F (100 °C)
SUS/100 °F (38 °C)



Viscosities are based on 95 VI single-grade oils. ISO grades are specified at 40 °C (105 °F). AGMA grades are specified at 100 °F (38 °C). SAE 75W, 80W, 85W, and 5 and 10W are specified at low temperature (below -17 °F (-25 °C)). Equivalent viscosities for 100 °F (38 °C) and 210 °F (100 °C) are shown. SAE 90 to 250 and 20 to 50 are specified at 210 °F (100 °C).

Appendix I-2

ISO viscosity grades

ISO viscosity grade	Kinematic viscosity at 40 °C (105 °F)		
	mean	min	max
–	mm ² /s		
ISO VG 2	2,2	1,98	2,42
ISO VG 3	3,2	2,88	3,52
ISO VG 5	4,6	4,14	5,06
ISO VG 7	6,8	6,12	7,48
ISO VG 10	10	9,00	11,0
ISO VG 15	15	13,5	16,5
ISO VG 22	22	19,8	24,2
ISO VG 32	32	28,8	35,2
ISO VG 46	46	41,4	50,6
ISO VG 68	68	61,2	74,8
ISO VG 100	100	90,0	110
ISO VG 150	150	135	165
ISO VG 220	220	198	242
ISO VG 320	320	288	352
ISO VG 460	460	414	506
ISO VG 680	680	612	748
ISO VG 1 000	1 000	900	1 100
ISO VG 1 500	1 500	1 350	1 650

Overview of SKF mounting tools and products

SKF offers a wide assortment of mounting tools and products. For additional information, visit www.mapro.skf.com.

Bearing fitting tool kit



Bearing lock nut spanners



Hook spanners



Working/heat/oil resistant gloves



Induction heaters



Portable induction heaters

new photo



Electric hot plates



Mounting fluid



Hydraulic pumps



Hydraulic nuts



Appendices

Oil injectors



Air-driven hydraulic pumps



Feeler gauges



SensorMount indicator



Anti-fretting agent



Overview of SKF alignment equipment

SKF offers a wide assortment of alignment equipment. For additional information, visit www.mapro.skf.com and www.skf.com/services.



Overview of SKF lubrication tools and products

SKF offers a wide assortment of lubrication products. For additional information, visit www.mapro.skf.com.

SKF also offers an assortment of centralized lubrication systems. For additional information, visit www.skf.com/lubrication.

Bearing greases and chain oils



Grease packers and grease guns



Grease filling pumps



Bearing packers



Oil handling containers



Grease meters



Single point automatic lubricators



Multi point automatic lubricators



Grease resistant gloves



Grease fittings



Oil levellers



new photo

SKF Lubrication Planner, and grease fitting caps and tags



Grease test kits

new photo



Compact greasers



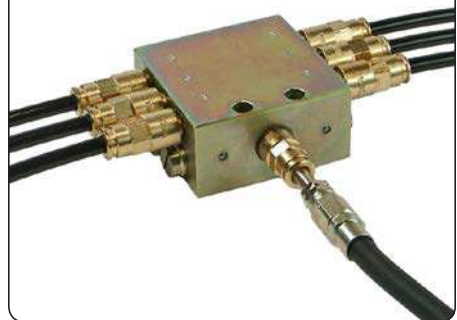
Battery driven piston pumps KFAS



Piston pump with block feeder PF-VPBM



Lubricating aids with metering distributor



LGMT 2

SKF general purpose industrial and automotive bearing grease

LGMT 2 is mineral oil based lithium soap thickened grease with excellent thermal stability within its operating temperature range. This premium quality, general purpose grease is suitable for a wide range of industrial and automotive applications.

Characteristics

- excellent oxidation stability
- good mechanical stability
- excellent water resistance and rust inhibiting properties

Recommended applications

- agricultural equipment
- automotive wheel bearings
- conveyors
- small electric motors
- industrial fans

LGMT 3

SKF general purpose industrial and automotive bearing grease

LGMT 3 is mineral oil based lithium soap thickened grease. This premium quality, general purpose grease is suitable for a wide range of industrial and automotive applications.

Characteristics

- excellent rust inhibiting properties
- high oxidation stability within its recommended temperature range

Recommended applications

- bearings with a bore diameter > 100 mm
- outer bearing ring rotation
- vertical shaft applications
- continuous high ambient temperatures >35 °C (95 °F)
- propeller shafts
- agricultural equipment
- car, truck and trailer wheel bearings
- large electric motors

LGEP 2

SKF heavy load, extreme pressure bearing grease

LGEP 2 is mineral oil based lithium soap thickened grease with extreme pressure additives. This grease provides good lubrication in operating temperatures ranging from -20 to $+110$ °C (-5 to $+230$ °F)

Characteristics

- excellent mechanical stability
- extremely good corrosion inhibiting properties
- excellent EP performance

Recommended applications

- pulp and paper machines
- jaw crushers
- dam gates
- work roll bearings in steel industry
- heavy machinery, vibrating screens
- crane wheels, sheaves

LGFP 2

SKF food compatible bearing grease

LGFP 2 is clean, non-toxic bearing grease, which is based on medical white oil using an aluminium complex soap. This grease is formulated using only FDA¹⁾ listed ingredients and is authorised by the NSF²⁾ for category H1³⁾ service.

Characteristics

- compliance with all existing legislation on food protection
- high resistance to water washout making it suitable for applications subject to frequent wash down
- excellent grease life
- excellent corrosion resistance
- an essentially neutral pH value

Recommended applications

- bakery equipment
- food processing equipment
- multi-pack cassette bearings
- wrapping machines
- conveyor bearings
- bottling machines

¹⁾ Food and Drug Administration

²⁾ National Sanitation Foundation

³⁾ Incidental contact with food

LGEM 2

SKF high viscosity bearing grease with solid lubricants

LGEM 2 is a premium quality, high viscosity, mineral oil based grease using a lithium soap containing molybdenum disulphide and graphite.

Characteristics

- good lubrication for bearings operating under heavy loads and slow rotation
- safe lubrication due to the inclusion of molybdenum disulphide and graphite

Recommended applications

- rolling element bearings running at low speed and very heavy loads
- jaw crushers
- track laying machines
- lift mast wheels
- building machines such as mechanical rams, crane arms and crane hooks

LGEV 2

SKF extremely high viscosity bearing grease with solid lubricants

LGEV 2 is a premium quality, extremely high viscosity, mineral oil based grease using a lithium-calcium soap containing molybdenum disulphide and graphite.

Characteristics

- excellent lubrication properties due to the inclusion of molybdenum disulphide and graphite solid
- very suitable for lubricating large spherical roller bearings subject to heavy loads and slow rotation, a situation where microslip is likely to occur
- extremely mechanically stable providing good water resistance and corrosion protection

Recommended applications

- trunnion bearings on rotating drums
- support and thrust rollers on rotary kilns and dryers
- bucket wheel excavators
- slewing ring bearings
- high pressure roller mills
- crushers

LGLT 2

SKF low temperature, extremely high speed bearing grease

LGLT 2 is premium quality, fully synthetic oil based grease using lithium soap. Its unique thickener technology and its low viscosity oil (PAO) provide excellent lubrication performance at low temperatures ($-50\text{ }^{\circ}\text{C}$ ($-60\text{ }^{\circ}\text{F}$)) and extremely high speeds, $n\text{ }d_m$ values of $1,6 \times 10^6$ can be reached.

Characteristics

- low frictional moment
- low level of power loss
- quiet running behaviour
- extremely good oxidation stability and resistance to water

Recommended applications

- textile spinning spindles
- machine tool spindles
- instruments and control equipment
- small electric motors used in medical and dental equipment
- in-line skates
- printing cylinders
- robots

LGGB 2

SKF green biodegradable bearing grease

LGGB 2 is biodegradable, low toxicity, synthetic ester oil based grease using a lithium-calcium thickener. It has excellent lubrication properties for a wide range of applications operating under different conditions.

Characteristics

- compliance with current regulations on toxicity and biodegradability
- good performance in applications with steel-on-steel spherical plain bearings, ball and roller bearings
- good low temperature start-up performance
- good corrosion inhibiting properties
- suitable for medium to heavy loads

Recommended applications

- agricultural and forestry equipment
- construction and earthmoving equipment
- mining and conveying equipment
- water treatment and irrigation
- locks, dams, bridges
- linkages, rod ends
- other applications where contamination of the environment is a concern

LGWM 1

SKF extreme pressure (EP) low temperature bearing grease

LGWM 1 is a mineral oil based grease using a lithium soap and containing extreme pressure additives. It is very suitable for the lubrication of bearings operating under both radial and axial loads, e.g. transport screws.

Characteristics

- good oil film formation at low temperatures down to $-30\text{ }^{\circ}\text{C}$ ($-20\text{ }^{\circ}\text{F}$)
- good pumpability at low temperature
- good corrosion protection
- good water resistance

Recommended applications

- windmills
- screw conveyors
- centralized lubrication systems
- spherical roller thrust bearing applications

LGWM 2

SKF heavy load, wide temperature bearing grease

LGWM 2 has been developed for lubrication under a wide temperature range, heavy loads and wet environments. LGWM 2 is a synthetic-mineral oil based grease using the latest complex calcium sulphonate thickener technology. LGWM 2 is suitable for temperatures down to $-40\text{ }^{\circ}\text{C}$ ($-40\text{ }^{\circ}\text{F}$).

Characteristics

- excellent corrosion protection
- excellent mechanical stability
- excellent heavy load lubricating capacity
- good false brinelling protection
- good pumpability down to low temperatures

Recommended applications

- wind turbines
- heavy-duty off road applications
- snow exposed applications
- marine applications
- spherical roller thrust bearing applications

LGWA 2

SKF heavy load, extreme pressure (EP), wide temperature range bearing grease

LGWA 2 is premium quality mineral oil based lithium complex grease with extreme pressure (EP) performance. LGWA 2 has such properties that it can be recommended for a wide range of industrial and automotive applications.

Characteristics

- excellent lubrication at peak temperatures up to 220 °C (430 °F) for short periods
- protection of wheel bearings operating under severe conditions
- effective lubrication in wet conditions
- good water and corrosion resistance
- excellent lubrication under heavy loads and low speeds

Recommended applications

- wheel bearings in cars, trailers and trucks
- washing machines
- electric motors

LGHB 2

SKF heavy load, high temperature, high viscosity bearing grease

LGHB 2 is a premium quality, high viscosity, mineral oil based grease using the latest complex calcium, sulphonate soap technology. This grease contains no additives and the extreme pressure characteristics are created within the soap structure.

Characteristics

- excellent anti-oxidation and anti-corrosion properties
- good EP performance in applications running at heavy loads

Recommended applications

- steel on steel plain bearings
- pulp and paper machines
- asphalt vibrating screens
- continuous casting machines
- sealed spherical roller bearings operating up to 150 °C (300 °F)
- withstands peak temperatures of 200 °C (390 °F)
- work roll bearings in steel industry
- mast rollers of fork lift trucks

LGHP 2

SKF high performance, high temperature bearing grease

LGHP 2 is premium quality mineral oil based grease, using a modern polyurea (di-urea) thickener. It is suitable for ball (and roller) bearings required to run extremely quiet, operating at a wide temperature range from -40 to $+150$ °C (-40 to $+300$ °F), at medium to high speeds.

Characteristics

- extremely long life at high temperature
- wide temperature range
- excellent corrosion protection
- high thermal stability
- good low temperature start-up performance
- compatibility with common polyurea greases
- compatibility with lithium complex thickened greases
- low noise level characteristics
- very good mechanical stability

Recommended applications

- electric motors: small, medium and large
- industrial fans, including high-speed fans
- water pumps
- rolling bearings in textile, paper processing and drying machines
- applications with high-speed ball bearings operating at medium and high temperatures
- clutch release bearings
- kiln trucks and rollers
- vertical shaft applications

LGET 2

SKF high temperature, extreme condition bearing grease

LGET 2 is premium quality, synthetic fluorinated oil based grease using a PTFE thickener. It has excellent lubrication properties at extremely high temperatures exceeding 200 to 260 °C (300 to 500 °F).

Characteristics

- long life in aggressive environments such as very reactive environments or areas with a presence of high purity gaseous oxygen or hexane
- excellent oxidation resistance
- good corrosion resistance
- excellent water and steam resistance

Recommended applications

- bakery equipment (ovens)
- kiln truck wheels
- load rollers in copying machines
- wafer baking machines
- textile dryers
- film stretching tenders
- electric motors running at extreme temperatures
- emergency/hot fans
- vacuum pumps

Appendices

SKF bearing grease selection chart

Designation	Temp	Speed	Load	Description	Temperature range ¹⁾		Thickener/ base oil	Base oil viscosity ²⁾
					LTL	HTPL		
					°C (°F)			
					–		mm ² /s	
LGMT 2	M	M	L to M	General purpose industrial and automotive	–30 (–20)	+120 (+250)	Lithium soap / mineral oil	110
LGMT 3	M	M	L to M	General purpose industrial and automotive	–30 (–20)	+120 (+250)	Lithium soap / mineral oil	120
LGEP 2	M	L to M	H	Extreme pressure	–20 (–5)	+110 (+230)	Lithium soap / mineral oil	200
LGFP 2	M	M	L to M	Food compatible	–20 (–5)	+110 (+230)	Aluminium complex / medical white oil	130
LGEM 2	M	VL	H to VH	High viscosity with solid lubricants	–20 (–5)	+120 (+250)	Lithium soap / mineral oil	500
LGVE 2	M	VL	H to VH	Extremely high viscosity with solid lubricants	–10 (+15)	+120 (+250)	Lithium-calcium soap / 1 020 mineral oil	
LGLT 2	L to M	M to EH	L	Low temperature, extremely high speed	–50 (–60)	+110 (+230)	Lithium soap / PAO oil	18
LGGB 2	L to M	L to M	M to H	Green biodegradable, low toxicity ³⁾	–40 (–40)	+90 (+195)	Lithium-calcium soap / synthetic ester oil	110
LGWM 1	L to M	L to M	H	Extreme pressure, low temperature	–30 (–20)	+110 (+230)	Lithium soap / mineral oil	200
LGWM 2	L to M	L to M	M to H	Heavy load, wide temperature	–40 (–40)	+110 (+230)	Calcium complex sulphonate / synthetic (PAO)/mineral oil	80
LGWA 2	M to H	L to M	L to H	Wide temperature ⁴⁾ , extreme pressure	–30 (–20)	+140 (+285)	Lithium complex soap / mineral oil	185
LGHB 2	M to H	VL to M	H to VH	EP high viscosity, high temperature ⁵⁾	–20 (–5)	+150 (+300)	Calcium complex sulphonate / mineral oil	400
LGHP 2	M to H	M to H	L to M	High performance polyurea grease	–40 (–40)	+150 (+300)	Di-urea / mineral oil	96
LGET 2	VH	L to M	H to VH	Extreme temperature	–40 (–40)	+260 (+500)	PTFE/synthetic (fluorinated polyether)	400

VL = very low, L = low, M = moderate, H = high, VH = very high, EH = extremely high

¹⁾ LTL = low temperature limit, HTPL = high temperature performance limit

²⁾ mm²/s at 40 °C (105 °F) = cSt

³⁾ LGGB 2 can withstand peak temperatures of 120 °C (250 °F)

⁴⁾ LGWA 2 can withstand peak temperatures of 220 °C (430 °F)

⁵⁾ LGHB 2 can withstand peak temperatures of 200 °C (400 °F)

Vertical shaft	Fast outer ring rotation	Oscillating movements	Severe vibration	Shock loads or frequent start-up	Low noise level	Low friction	Rust inhibiting properties
-	-	-	-	-	-	-	-
0	-	-	+	-	-	0	+
+	0	-	+	-	-	0	0
0	-	0	+	+	-	-	+
0	-	-	-	-	-	0	+
0	-	+	+	+	-	-	+
0	-	+	+	+	-	0	0
0	-	-	-	0	+	+	0
0	-	+	+	+	-	0	0
-	-	+	-	+	-	-	+
0	0	+	+	+	-	-	+
0	0	0	0	+	-	0	+
0	+	+	+	+	-	-	+
+	-	-	0	0	+	0	+
0	+	+	0	0	-	-	0

Symbols: + Recommended
 0 Suitable
 - Not suitable

Overview of SKF basic condition monitoring instruments

SKF offers a wide assortment of basic condition monitoring instruments. For additional information, visit www.mapro.skf.com or www.skf.com/cm.

For information about advanced condition monitoring instruments and on-line monitoring systems, visit www.skf.com/cm.

Thermal imagers

New photo



Thermometers

new photo



Electronic stethoscopes



Endoscopes

Product replaced !



Stroboscopes

New photo



Oil condition monitors

Photo updated



Tachometers

Silver coloured product discontinued.

Note: black coloured product still exists



Sound pressure meters



Ultrasonic leak detectors



SKF Machine Condition Advisor

New photo CoMo



Appendices

Ultrasonic probe kits



Condition monitoring kits (basic)



Specialized condition monitoring kits

Product replaced ! COMO



SKF MicroVibe P

Product replaced COMO



Machine condition detectors



Overview of SKF dismounting tools and products

SKF offers a wide assortment of dismounting tools. For additional information, visit www.mapro.skf.com.

Mechanical pullers



Hydraulic pullers



Heavy-duty jaw pullers



Pulling plates



Internal bearing puller kits

Appendices

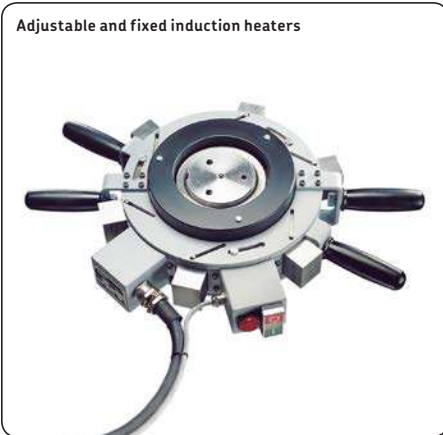
Blind housing puller kits



Aluminium heating rings



Adjustable and fixed induction heaters



Hydraulic nuts



Dismounting fluid



Unit conversion table

Quantity	Unit	Conversion			
Length	inch	1 mm	0,03937 in	1 in	25,40 mm
	foot	1 m	3,281 ft	1 ft	0,3048 m
	yard	1 m	1,094 yd	1 yd	0,9144 m
	mile	1 km	0,6214 mile	1 mile	1,609 km
Area	square inch	1 mm ²	0,00155 sq.in	1 sq.in	645,16 mm ²
	square foot	1 m ²	10,76 sq.ft	1 sq.ft	0,0929 m ²
Volume	cubic inch	1 cm ³	0,061 cub.in	1 cub.in	16,387 cm ³
	cubic foot	1 m ³	35 cub.ft	1 cub.ft	0,02832 m ³
	imperial gallon	1 l	0,22 gallon	1 gallon	4,5461 l
	U.S. gallon	1 l	0,2642 U.S. gallon	1 U.S. gallon	3,7854 l
Velocity, speed	foot per second	1 m/s	3,28 ft/s	1 ft/s	0,30480 m/s
	mile per hour	1 km/h	0,6214 mile/h (mph)	1 mile/h (mph)	1,609 km/h
Mass	ounce	1 g	0,03527 oz	1 oz	28,350 g
	pound	1 kg	2,205 lb	1 lb	0,45359 kg
	short ton	1 tonne	1,1023 short ton	1 short ton	0,90719 tonne
	long ton	1 tonne	0,9842 long ton	1 long ton	1,0161 tonne
Density	pound per cubic inch	1 g/cm ³	0,0361 lb/cub.in	1 lb/cub.in	27,680 g/cm ³
Force	pound-force	1 N	0,225 lbf	1 lbf	4,4482 N
Pressure, stress	pounds per square inch	1 MPa	145 psi	1 psi	6,8948 × 10 ³ Pa
Moment	inch pound-force	1 Nm	8,85 in.lbf	1 in.lbf	0,113 Nm
Power	foot-pound per second	1 W	0,7376 ft lbf/s	1 ft lbf/s	1,3558 W
	horsepower	1 kW	1,36 HP	1 HP	0,736 kW
Temperature	degree	Celsius	t _C = 0,555 (t _F - 32)	Fahrenheit	t _F = 1,8 t _C + 32

Index

- @
 - @ptitude Exchange See SKF @ptitude Exchange
- A**
- abrasive paper 226
- abrasive wear 298–299
 - caused by incorrect fits 300–301
 - caused by ineffective lubrication 313
 - caused by ineffective sealing 314–315
- abutments
 - accuracy requirements 35–36, 386
 - dimensions 38
 - trouble conditions 237, 251
- acrylic rubber 201
- acrylonitrile-butadiene rubbers
 - designation suffixes for bearings 24–25
 - designation suffixes for seals 145
- adapter sleeve locking 94–95
 - dismounting bearing units 274
 - mounting bearing units 109–110
 - tightening torque values 103
- adapter sleeves
 - dismounting bearings 260–264
 - dismounting flanged housings 282
 - mounting bearings (oil injection method) 62–66
 - mounting bearings (SKF Drive-up Method) 57–61
- additives
 - compatibility with materials 188–189, 202, 207, 210
 - in centralized lubrication systems 212
 - in grease 184
 - in oil 203
- adhesive wear 298–299
 - caused by incorrect fits 301
 - caused by ineffective lubrication 312
- adjustable steel levellers See SKF Vibracon SM elements
- adjusted bearing arrangements 31
 - axial location 37–38
- adjusting bearings
 - angular contact ball bearings 74–77
 - tapered roller bearings 84–88
 - troubleshooting 245
- alignment 158–177
 - of belts 176–177
 - of machines 161–166
 - of offset drives 175
 - of shafts 167–174
 - SKF equipment 419
- allen keys See hexagonal keys
- aluminium heating rings
 - for dismounting bearings 255, 258–259
 - for mounting bearings 69, 81
- ambient temperature
 - considerations for machine alignment 161
 - considerations for relubrication 195–196
- angled foot See soft foot
- angular contact ball bearings
 - adjusting back-to-back arrangements 76–77
 - adjusting face-to-face arrangements 74–75
 - axial internal clearance values 389
 - axial preload values 389
 - greasing on initial installation 191
 - mounting 74–78
 - stand-alone bearings 74
 - trouble conditions 243, 245, 247
 - types and designs 12–13
 - universally matchable bearings 76
 - with a two-piece inner ring 78
- anti-foaming additive 203
- anti-fretting agent 49
- anti-oxidant additive
 - in grease 184
 - in oil 203
- anti-rust additive
 - in grease 184
 - in oil 203
- anti-wear additive
 - in grease 184
 - in oil 203, 207
- assembling ball bearing units 121
- asset management 326–329
- asset reliability 326–329
- associated components
 - checking the accuracy 47–49
 - dimensions for ducts, grooves and holes 405
 - greasing on initial installation 188
 - preparations 49
- attachment bolts/nuts
 - compensating for soft foot 162
 - for bearing units 101, 105
 - for housings 131
- automatic lubrication 197
- automatic lubricators See SKF SYSTEM 24
- automatic particle counting method 212
- auxiliary lips
 - greasing on initial installation 149, 190
 - seal types and designs 143–145
- axial displacement 30–31
 - considerations for fit selection 34
 - for CARB toroidal roller bearings 91
 - in plummer block housings 132
 - measuring axial drive-up 56–57
 - values for SKF Drive-up Method 406–413
- axial drive-up
 - measuring axial displacement 56
 - measuring clearance reduction 55
 - troubleshooting 240
 - values for CARB toroidal roller bearings 404
 - values for self-aligning ball bearings 402
 - values for spherical roller bearings 403
- axial internal clearance 29, 51
 - trouble conditions 248
 - values for angular contact ball bearings 389–391
 - values for cylindrical roller bearings 394–395
 - values for tapered roller bearings 396

axial load
induced loads 241, 243–244, 301, 320
path patterns 294–295
axial location 37–38
in plummer block housings 132

B

back-to-back bearing arrangements
adjusting angular contact ball bearings 76–77
adjusting tapered roller bearings 86–88
ball bearing units
assembly 121
designations 96, 100
dismounting 272–275
mounting 104–114
shaft locking methods 94–96
types and designs 96–100
base frame See machine base frame
base oil
compatibility 200–201
in grease 183
in oil 203
viscosity 185
base-bound 167, 175
basic rating life 27
bearing arrangements
in plummer block housings 127, 132
terminology 11
types 30–31
bearing damage 288–323
causes 230–231, 298
ISO classification 298
operational 309–322
pre-operational 300–308
symptoms 232–235
bearing failure See bearing damage
bearing housings See housings
bearing life
rating life 27–28
service life 28–29
bearing location 31–38
bearing seats
accuracy requirements 35–36, 386
bearing damage 302–303
checking the accuracy 47–49
dimensions for relieved fillets 387
surface roughness 36, 387
bearing units
designations 96, 100
dismounting 270–277
identification 27
mounting 92–121
shaft locking methods 94–96
storage 41
types and designs 96–100
bearings
defect frequencies 224
designation system 22–25
dismounting 254–269
greasing on initial installation 189–191
handling 49–50
identification 26–27
inspection 225–226
mounting 44–91
relubrication 194–198
size categories 46
storage 41, 230
terminology 10
types and designs 12–21
belt alignment 176–177
bolt tensioners 166
bolt-bound 167, 175
brass
compatibility with EP additives 202
for machinery shims 163

C

calcium soap 185
calibrated cones
for belt alignment 176
for shaft alignment 170
cap bolts 131
CARB toroidal roller bearings
abutment dimensions 38
axial drive-up values 404
axial location 37
clearance reduction values 404
greasing on initial installation 191
in plummer block housings 132
lock nut tightening angles 404
mounting 90–91
mounting (oil injection method) 62–66
mounting (SKF Drive-up Method) 57–61
radial internal clearance values 399–400
SKF Drive-up Method values 412–413
trouble conditions 240
types and designs 17
cardan shaft alignment See offset drive alignment
cast iron
bearing unit housings 100
housings 126
cast steel 126
castle nuts 88
centralized lubrication systems 213–215
centring flanges 84–85
chain oils 209
for SKF SYSTEM 24 lubricators 199
chocking See shiming
chocks 164
churning
caused by excess grease 190, 199
caused by vibration 194
resulting in lubricant leakage 222
troubleshooting 236
CircOil See SKF CircOil
circulating oil 208
in centralized lubrication systems 213–215
mounting SONL housings 137–139
oil change interval 209
taking oil samples 210
cleaning
bearings 226
seals 146
cleanliness 28–29, 46–47
clearance See internal clearance
clearance reduction 54–55
values for CARB toroidal roller bearings 404
values for spherical roller bearings 403
Client Needs Analysis See SKF Client Needs Analysis
cold mounting 53–67
compatibility
between base oils 201
between thickeners 201
grease 200–202
oil 210
complex soaps 183
composite material See polyamide
compressed air 226
ConCentra See SKF ConCentra
condition monitoring 216–224
lubrication 222
noise 221
SKF instruments 432–434
temperature 221
conditions of rotation 32
consistency 185
grease performance test 188
consistency grade See NLGI grade
contact seals
external seals 39
integral bearing seals 40
removal 284–286
trouble conditions 238

Index

- contamination
 - bearing damage progression 231
 - contaminants 211–212
 - ISO classification 212
 - relubrication interval adjustment 195
 - resulting in abrasive wear 314–315
 - resulting in indentations 316
 - troubleshooting 245–246, 249–250
- continuous relubrication 195, 197
- copper corrosion test 188
- corrective maintenance *See* reactive maintenance
- corrosion 298–299
 - frictional corrosion 302–303, 308, 319
 - moisture corrosion 308, 317–318
- corrosion protection test 188
- cracking 298–299
- crackle test 211
- cracks
 - caused by defective seats 303
 - caused by incorrect fits 300–301
 - microcracks 309–312
- craters 321–322
- creep 31
 - caused by incorrect fits 300–301
 - considerations for fit selection 33
 - troubleshooting 243, 246–247
- cross holes 150, 152
- cross-location *See* adjusted bearing arrangements
- current leakage 298–299
 - caused by passage of electric current 321–322
- cylindrical collar locking 94–95
 - mounting bearing units 119–120
 - tightening torque values 102
- cylindrical roller bearings
 - axial internal clearance values 394–395
 - axial location 37
 - dismounting 258–259
 - greasing on initial installation 191
 - mounting 80–84
 - radial internal clearance values 393
 - types and designs 13–14
- cylindrical shaft seats
 - dismounting bearings 256–259
 - form and position accuracy 386
 - measurement form 48
 - mounting bearings 53
- cylindricity 36, 386
- D**
- deep groove ball bearings
 - greasing on initial installation 191
 - integral bearing seals 40
 - radial internal clearance values 388
 - types and designs 12
- defect frequencies 224
- dents *See* indentations
- designations
 - for bearing units 96–100
 - for bearings 22–25
 - for housings 125–129
 - for seals 143–145
- dial indicator methods
 - for adjusting angular contact ball bearings 74–77
 - for adjusting tapered roller bearings 86–88
 - for shaft alignment 170–171
 - for SKF Drive-up Method 58–61
- dial indicators 56
- diameter series 22–23
- direction of load indeterminate 32
- dismounting bearing units 270–277
 - preparations 271
 - tools 270
 - with an adapter sleeve 274
 - with an eccentric locking collar 273
 - with grub screw locking 272
 - with SKF ConCentra locking 275–277
- dismounting bearings 254–269
 - from a cylindrical shaft seat 256–259
 - from a solid housing 267–269
 - from a tapered shaft seat 259–260
 - methods 255
 - preparations 254
 - tools 255, 435–436
 - using heat 258–259, 269
 - when bearing damage is present 291
 - with a withdrawal sleeve 264–267
 - with an adapter sleeve 260–264
- dismounting fluid 254
- dismounting housings 278–283
 - flanged housings 282–283
 - preparations 278
 - split plunger blocks 280–281
- dismounting seals *See* removing seals
- distance rings 134
- double row angular contact ball bearings
 - axial internal clearance values 390
 - designs 12
 - mounting 78
- double row tapered roller bearings
 - designs 17
 - mounting 89
- double-lip seals
 - grease replenishment 196
 - greasing on initial installation 149, 190
- drift punches
 - for installing seals 148
 - for mounting bearing units 107–108
- drive-up *See* axial drive-up
- drive-up method *See* SKF Drive-up Method
- dropping point 185
 - grease performance test 188
- dry lubricant 182–183
- Duoflex *See* SKF Duoflex
- Duralife *See* SKF Duralife
- Duralip *See* SKF Duralip
- DURATEMP 145
- E**
- eccentric collar locking 94–95
 - dismounting bearing units 273
 - mounting bearing units 106–108
 - tightening torque values 102
- elastomer seals
 - installation 140–157
 - storage 42
- electric current
 - current leakage damage 321–322
 - excessive voltage damage 307
 - trouble conditions 249–250
- electric hot plates 68
- electrical erosion 298–299
 - current leakage 321–322
 - excessive voltage 307
- electronic stethoscopes 221
- EMCOR rating *See* SKF EMCOR rating
- end covers 133
- endoscopes 225–226
- energy efficiency 329
- enveloped acceleration 224
- EP additives *See* extreme pressure additives
- Epocast 36 165
- epoxy resin
 - for machine alignment 165
 - for shaft repair 152
- escape holes *See* grease escape holes
- external seals 39
 - trouble conditions 238
- extractors *See* pullers
- extreme pressure additives
 - compatibility with materials 202, 207
 - in grease 184
 - in oil 203, 207
- extreme temperature applications 182

F

face alignment 176–177
face-to-face bearing arrangements
 adjusting angular contact ball bearings 74–75
 adjusting tapered roller bearings 84–85
failure analysis See bearing damage
failure modes 298–299
false brinelling 298–299
 caused by incorrect transportation or storage 308
 caused by vibration 319
fatigue 298–299
 subsurface initiated 301, 303–304
 surface initiated 301, 303–304, 310–311
fatigue fracture 298–299
 caused by operational misalignment 319
faults See machine faults
feeler gauges
 for belt alignment 176
 for checking soft foot 162
 for measuring clearance reduction 55
 for measuring internal clearance 52
 for shaft alignment 170
felt seals 238
field service contracts 330
fillets
 dimensions 38
 dimensions (relieved fillets) 387
 trouble conditions 247
filter rating 212
fits
 bearing damage 300–302
 for housings 336–337
 for shafts 334–336
 resultant fits 338–381
 selection 32–34
 trouble conditions 241–242, 246
FKM See fluoro elastomer
flanged housings
 dismounting 282–283
 types and designs 125–126
flanged units 100
 dismounting 270–277
 mounting 104–120
 types and designs 96–100
flourinated grease 189, 200, 202
fluoro elastomer
 at high temperatures 142
 designation suffix for seals 145
fluting
 caused by electric current 322
 caused by vibration 319
foam dam 165
foaming
 causes 211
 prevention 202
food compatible lubricants 209, 424
forced fracture 298–299
 caused by defective seats 303
 caused by incorrect fits 301
form accuracy 35–36
 tolerances for bearing seats 386
 tolerances for shafts (sleeve mounting) 384
foundation quality 161
four-lip seals
 grease replenishment 196
 greasing on initial installation 190
four-point contact ball bearings
 axial internal clearance values 391
 designs 13
 mounting 78
 trouble conditions 244
four-row cylindrical roller bearings
 designs 14
 mounting 82–84
four-row tapered roller bearings
 designs 17
 mounting 89

fracture 298–299
 fatigue fracture 319
 forced fracture 301, 303
 thermal cracking 301
FRB rings See locating rings
fretting corrosion 298–299
 caused by defective seats 302–303
 caused by incorrect fits 300
 grease performance test 188
 removal 226
frictional corrosion 298–299
 false brinelling 308, 319
 fretting corrosion 298–299, 302–303
frictional moment 235

G

garter springs
 seal types and designs 143–145
 trouble conditions 237
gloves 73
graphite 182, 184
grease
 ageing 187, 192, 195
 analysis 222
 comparison with oil 182, 214
 compatibility 200–202
 consistency 185, 188
 datasheets 181, 184–188
 function 184
 operating temperature range 186–187
 performance tests 188
 properties 185–188
 selection 189
 selection chart (SKF greases) 430–431
 SKF greases 423–431
 stiffness 184, 187
grease escape holes 196, 199
grease fittings
 for grease replenishment 195
 position on plunger block housings 133, 196
grease leakage 182
 grease performance tests 188
 troubleshooting 202, 236, 238–239
grease lubrication 183–202
Grease Test Kit See SKF Grease Test Kit
groove alignment 176–177
grub screw locking 94–95
 dismounting bearing units 272
 mounting bearing units 104–106
 tightening torque values 102
guide rods 81
guiding sleeves See mounting sleeves

H

hammers
 for installing seals 146
 for mounting bearings 49
handling
 bearing damage 305–306, 308
 bearings 49–50
 lubricants 181
heat
 condition monitoring 221
 troubleshooting 233
heater mats 269
heating cabinets 70
heating panels 71
heating rings See aluminium heating rings
hexagonal keys 102
high-precision bearings
 greasing on initial installation 191
 types and designs 12, 18
HMV.. nuts See hydraulic nuts
HNBR See acrylonitrile-butadiene rubbers
hollow shafts 34–35
hook spanners 102–103
hot dismounting See dismounting bearings, using heat
hot mounting 68–71

Index

- housings
 - dismounting 278–283
 - greasing on initial installation 190
 - identification 27
 - mounting 122–139
 - terminology 11
 - types and designs 125–127
- hubs *See* wheel hubs
- humidity
 - when storing bearings and units 41
 - when storing elastomer seals 42
 - when storing lubricants 43
- hydraulic nuts
 - for dismounting bearings 262, 266
 - for SKF Drive-up Method 56, 406–413
 - series and designs 73
- hydraulic pumps
 - for SKF Drive-up Method 56
 - selection guide 72
- hydraulically-assisted pullers 257, 260
- HYDROCAM 166
- I**
- imbalance 223
- impact damage
 - caused by faulty mounting practices 248, 305
 - caused by incorrect transportation or storage 308
- impact rings/sleeves 146
- incompatibility *See* compatibility
- indentations 298–299
 - bearing damage progression 211, 231
 - caused by faulty mounting practices 305–306
 - caused by ineffective sealing 316
 - troubleshooting 245, 248
- induced loads 301, 320
 - troubleshooting 241, 243–244
- induction heaters
 - for dismounting bearings 255, 259
 - for installing wear sleeves 152
 - for mounting bearings 69, 82
- infrared radiators 70
- initial clearance 29
- inner ring expansion 56
- insert bearings *See* Y-bearings
- inspection 216–227
 - during operation 220–224
 - during shutdown 224–227
 - lubricants 181
- installing seals 140–157
 - greasing on initial installation 190
 - in plummer block housings 133–139
 - trouble conditions 238–239
- integral seals
 - for bearing units 96
 - for bearings 40
 - trouble conditions 237–238, 251
- integrated maintenance solutions 329
- internal bearing pullers 268
- internal clearance
 - before and after mounting 29, 51
 - considerations for fit selection 33
 - initial 29, 51
 - measuring with a feeler gauge 52
 - operational 29
 - reduction values when mounting 403–404
 - residual values after mounting 403–404
 - troubleshooting 233, 234, 239–242
 - values prior to mounting 388–401
- ISO
 - bearing damage classification 298
 - contamination classification 212
 - dimension series 22–23
 - tolerance classes 35
 - tolerance grades 385
 - viscosity grades 203, 415
- K**
- keyways 150, 152
- kiln bearings 182
- kinematic viscosity *See* viscosity
- L**
- labyrinth seals 39
 - grease replenishment 196
 - greasing on initial installation 190
 - installation in plummer block housings 136
 - trouble conditions 238
- large diameter wear sleeves 225
 - installation 152–153
- laser alignment methods
 - for belt alignment 176–177
 - for offset drive alignment 175
 - for shaft alignment 171–173
- leaks 222
 - troubleshooting 236, 238–239, 245
- life *See* bearing life
- lifting tackle 50, 68
- liquid contaminants 212
 - troubleshooting 246, 250
- lithium soap 185
- load distributions
 - considerations for fit selection 32
 - path patterns 292–297
- load ratios 187
- load zones 292–297
- locating bearing arrangements 30–31
- locating rings 132
- lock nut tightening angle 55
 - values for CARB toroidal roller bearings 404
 - values for self-aligning ball bearings 402
 - values for spherical roller bearings 403
- looseness 163, 220
- LuBase 189, 207
- LubeSelect 189, 192, 207
- lubricant
 - disposal 181
 - handling 181
 - inspection 181, 222, 225
 - selection 182
 - service life 28
 - shelf life 43
 - storage 42
- lubricant film
 - formation 204
 - load carrying capacity 184, 200
- lubrication 178–215
 - management 180
 - SKF tools and products 420–422
 - trouble conditions 236–237
- lubrication systems
 - centralized 213–215
 - oil 207–209
- LubriLean *See* SKF LubriLean
- M**
- machine alignment 161–166
- machine base frame
 - casting epoxy resin 165
 - soft foot condition 162
- Machine Condition Advisor *See* SKF Machine Condition Advisor
- machine faults 222
- machine installation 161–166
- machine tools
 - lubrication 191, 215
 - SKF services 331
- machinery shims 163–164
 - for adjusting angular contact ball bearings 74–75
 - for adjusting tapered roller bearings 85
 - for bearing units 101
 - for plummer block housings 130
 - in the TMAS series 164
 - to prevent axial preloading 244
 - trouble conditions 241
- maintenance methodologies 218–219

maintenance strategy review 328–330
 maintenance support 324–331
 mandrels 146
 matched bearing sets 76
 material fatigue See subsurface initiated fatigue
 material safety datasheets 180
 interpretation 184–188
 measurement form 48
 mechanical maintenance services 330
 mechanical pullers 256, 260
 mechanical stability 188
 metal-to-metal contact
 prevention 183, 202
 resulting in adhesive wear 312
 troubleshooting 233–234, 237, 246, 249
 microcracks 299
 caused by ineffective lubrication 310
 caused by material fatigue 309
 micrometers 47–49
 microscope counting method 212
 mineral oil
 in grease 183, 189
 in oil 203–204
 minimal quantity lubrication 214–215
 misalignment
 bearing damage 304, 320
 in ball bearing units with an adapter sleeve 110
 in ball bearing units with an eccentric locking collar 106, 108
 in ball bearing units with grub screw locking 104, 106
 in roller bearing units with a cylindrical locking collar 119
 in SKF ConCentra ball bearing units 112, 114
 in SKF ConCentra roller bearing units 116, 118
 of belts 176–177
 of external seals 238
 of offset drives 175
 of shafts 167–169
 path patterns 296–297
 vibration frequencies 222–223
 mixing greases See grease, compatibility
 moisture corrosion 298–299
 caused by incorrect transportation or storage 308
 caused by ineffective sealing 317–318
 troubleshooting 250
 molybdenum disulphide
 for mounting bearings 62
 in grease 183
 Monoflex See SKF Monoflex
 mounting bearing units 92–121
 preparations 101
 replacement parts 94–100
 tightening torque values 102–103
 tools 102–103
 with a cylindrical locking collar 119–120
 with an adapter sleeve 109–110
 with an eccentric locking collar 106–108
 with grub screw locking 104–106
 with SKF ConCentra locking 111–118
 mounting bearings 44–91
 faulty mounting practices 248–249, 305–306
 instructions by bearing type 74–91
 preparations 46–49
 tools 72–73, 416–418
 trouble conditions 240, 243, 245, 247
 using mechanical methods 53–56
 using the oil injection method 62–66
 using SensorMount 67
 using the SKF Drive-up Method 57–61
 mounting housings 122–139
 plummer blocks 134–136
 plummer blocks (SONL) 137–139
 preparations 130
 replacement parts 124–129
 mounting sleeves
 for installing seals 150
 for mounting cylindrical roller bearings 81–84
 movable machine 167–169
 Multiflex See SKF Multiflex

multi-row tapered roller bearings See four-row tapered roller bearings

N

natural oil
 in grease 183
 in oil 203
 NBR See acrylonitrile-butadiene rubbers
 needle roller bearings
 dismounting 255, 258
 mounting 80–81
 radial internal clearance values 393
 types and designs 15–16
 NLGI grade 184
 grease performance test 188
 noise
 condition monitoring 221
 troubleshooting 233
 non-contact seals
 external seals 39
 integral bearing seals 40
 removal 284
 non-locating bearing arrangements 30–31
 non-separable bearings 190
 non-soaps 183

O

offset drive alignment 175
 oil
 analysis 210–212
 comparison with grease 182, 214
 compatibility 201, 210
 filtering 211–212
 sampling 210
 selection 203–207
 viscosity 203–206
 oil bath 208
 for heating bearings 71
 oil change interval 209
 oil sampling 210
 trouble conditions 236–237
 oil bleeding 181, 184, 187
 grease performance test 188
 relubrication interval adjustment 205
 oil change intervals 209
 oil injection method
 dimensions for ducts, grooves and holes 405
 for dismantling a bearing from a solid housing 268
 for dismantling a bearing on a cylindrical shaft seat 258
 for dismantling a bearing on a tapered shaft seat 260
 for dismantling a bearing on a withdrawal sleeve 266
 for dismantling a bearing on an adapter sleeve 264
 for mounting bearings 62–66
 oil injectors 72
 oil jet 208
 oil change interval 209
 oil leakage 182
 troubleshooting 236
 oil level gauge 137, 139
 oil lubrication 203–212
 oil lubrication systems 207–209
 oil pick-up ring 207–208
 in SONL housings 137–139
 oil change interval 209
 oil pressure
 calculation for SKF Drive-up Method 58
 values for SKF Drive-up Method 406–413
 oil separation See oil bleeding
 oil spot See oil-air
 oil-air 207–208
 SKF Oil+Air 215
 one-piece plummer block housings 126
 on-site machining 330

Index

operating temperature
 condition monitoring 221
 of bearings 187, 204
 of grease 186–187
 relubrication interval adjustment 195
 troubleshooting 190, 202, 233
operational clearance 29
operator driven reliability 219, 330
O-rings 39
oscillating applications 207
outer ring rotation
 load conditions 32
 path patterns 293
 relubrication interval adjustment 195
 wheel application 87–88
out-of-balance *See* unbalance
out-of-round 241
 caused by defective seats 302–303
 path patterns 296–297
 troubleshooting 241
out-of-square
 caused by defective seats 302
 caused by static misalignment 304
 troubleshooting 251
oval clamping *See* out-of-round
overheating 233
overload 298–299
 caused by faulty mounting practices 305
 caused by incorrect transportation or storage 308
over-rolling 231
 bearing defect frequencies 224
oxidation
 of grease 187
 prevention 81, 185, 203
 resulting in corrosion 299
oxidized lubricant 226, 254

P

paint
 on support surfaces 130, 161, 165
 seal protection 150
particle counting 212
path patterns 291–297
perpendicularity 36, 386
pick-up ring *See* oil pick-up ring
pillow block *See* plummer block
pinching *See* out-of-round
plastic deformation 298–299
 indentations 305–306, 316
 overload 305, 308
plugs *See* end covers
plummer block housings
 dismounting 280–281
 mounting SNL housings 134–136
 mounting SONL housings 137–139
 types and designs 125–126
plummer block units
 dismounting 270–277
 mounting 104–120
 types and designs 96–100
polishing wear
 caused by incorrect fits 300–301
 caused by ineffective sealing 315
polyamide
 bearing unit housings 100
 compatibility with EP additives 202
polyurea 183
predictive maintenance 218–219
preload
 operational 29, 51
 troubleshooting 240–245
 values for angular contact ball bearings 389
premature bearing failure *See* bearing damage
preservatives
 compatibility 189, 202
 removal from new bearings 47, 202
pressed steel 100

presses
 for dismounting bearings 258, 267
 for installing seals 146
 for mounting bearings 53
pressure gauges 56
preventive maintenance 218–219
proactive reliability maintenance 219
ProFlex *See* SKF ProFlex
PTFE
 at high temperatures 142
 compatibility 202
 designation suffix for seals 145
 radial shaft seals 143, 146, 150
pullers
 for dismounting a bearing from a solid housing 267–269
 for dismounting a bearing on a cylindrical shaft seat 256–257
 for dismounting a bearing on a tapered shaft seat 260
 for dismounting flanged housings 282
pulley alignment *See* belt alignment
pulling plates 260
pumps
 for SKF Drive-up Method 56
 selection guide 72
purging
 during relubrication 196
 during renewal 199
 trouble conditions 239

R

radial bearings 12–17
radial internal clearance 29, 51
 measuring with a feeler gauge 52
 reduction values when mounting 403–404
 residual values after mounting 403–404
 values for angular contact ball bearings 389–390
 values for CARB toroidal roller bearings 399–400
 values for cylindrical roller bearings 393
 values for deep groove ball bearings 388
 values for four-point contact ball bearings 391
 values for needle roller bearings 393
 values for self-aligning ball bearings 392
 values for spherical roller bearings 397–398
 values for Y-bearings 401
radial location 31–36
 trouble conditions 241–242, 246
radial shaft seals
 cleaning 146
 installation into a housing 146–149
 installation over a shaft 150
 replacement 151
 types and designs 143–145
radiators *See* infrared radiators
rating life 27–28
reactive maintenance 218–219
recommended fits *See* fits
reference temperature 203
refurbishment 331
reheat furnaces 182
reliability engineering 327
relieved fillets 38
 dimensions 387
relubrication 192–198
 effect on temperature 221
 of sealed bearings 90, 192
relubrication intervals 192–195
 troubleshooting 236, 245–246
remanufacturing 331
removing seals 284–286
renewal 198–199
replacement parts
 for bearing units 94–100
 for housings 124–129
 for seals 142–145
replenishment 195–196

resultant fits
 for housings (inch) 372–381
 for housings (metric) 350–359
 for shafts (inch) 360–371
 for shafts (metric) 338–349
 retaining rings 91
 reverse rim method 170–171
 rim-face method 170–171
 ring creep *See* creep
 ring gauges 47
 RMI *See* SKF Reliability Maintenance Institute
 roll neck bearings 259
 roll stability 188
 roller bearing units
 designations 96, 100
 dismounting 276–277
 mounting 114–120
 shaft locking methods 94–96
 types and designs 96–100
 rolling bearings *See* bearings
 rotating load 32
 troubleshooting 243
 rotating outer ring
 load conditions 32
 path patterns 293
 relubrication interval adjustment 195
 wheel application 87–88
 rotational centre 167
 rubbing 233
 running accuracy 35–36
 tolerances for bearing seats 386
 tolerances for shafts (sleeve mounting) 384
 running-in 191
 runout 36
 tolerances for bearing seats 386
 rust
 caused by defective seats 302
 caused by ineffective sealing 317–318
 troubleshooting 246
 rust inhibiting preservative 188
 compatibility with greases 189, 202
 removal 202

S

safety datasheets *See* material safety datasheets
 salt water 185
 seal counterface 142
 inspection 226–227
 repair 151–154
 requirements 146
 seal lips
 made of PTFE 146
 materials 145
 orientation 146, 239
 types and designs 143–145
 sealants
 for installing seals 148, 152
 to prevent oil leakage 137
 sealed bearings 40
 deep groove ball bearings 40
 heating 68
 relubrication 192
 self-aligning ball bearings 79
 shelf life 41
 spherical roller bearings 90
 trouble conditions 238
 washing 189
 sealing arrangements 39–40
 trouble conditions 238
 sealing washers 156

seals
 external seals 39
 for bearing units 96
 for housings 128–129
 installation 140–157
 integral bearing seals 40
 radial shaft seals 143–145
 removal 284–286
 service life 28
 shelf life 42
 terminology 11
 trouble conditions 233, 235
 seats *See* bearing seats
 self-aligning ball bearings
 axial drive-up values 402
 greasing on initial installation 191
 lock nut tightening angles 402
 mounting 79–80
 mounting (oil injection method) 62–66
 mounting (SKF Drive-up Method) 57–61
 radial internal clearance values 392
 SKF Drive-up Method values 392
 types and designs 13
 SensorMount 67
 separable bearings
 greasing on initial installation 190
 mounting 80
 serial numbers
 on four-point contact ball bearings 78
 on four-row cylindrical roller bearings 82
 on four-row tapered roller bearings 89
 on plummer block housings 27
 service life 28–29
 influencing factors 230–231
 set screw *See* grub screw
 shaft alignment 167–174
 measuring conventions 167–168
 methods 170–173
 tolerances 169
 shaft locking methods 94–96
 shaft movement 234
 shaft repair 152–154
 shelf life
 of bearings 41
 of elastomer seals 42
 of lubricants 43
 shields 40
 shimmying 163
 shims *See* machinery shims
 shock loading
 additive requirements 207
 bearing damage 248, 308
 relubrication interval adjustment 195
 Shopfloor Awareness Cards 330
 short foot *See* soft foot
 sine bars 47
 size code 22
 SKF @ptitude Decision Support 327
 SKF @ptitude Exchange 327
 SKF Authorized Distributors 331
 SKF Bearing fitting tool kit
 for installing seals 146
 for mounting bearings 72
 SKF Certified Electric Motor Rebuilders 331
 SKF Certified Maintenance Partners 331
 SKF CircOil 215
 SKF Client Needs Analysis 328
 SKF ConCentra ball bearing units
 dismounting 275
 mounting 111–114
 SKF ConCentra locking 94–95
 SKF ConCentra roller bearing units
 dismounting 276–277
 mounting 114–118

Index

- SKF Drive-up Method 57–61
 - axial displacement values 406–413
 - hydraulic nuts 406–413
 - oil pressure values 406–413
 - tools 56–57
 - SKF Duoflex 215
 - SKF Duralife 145
 - SKF Duralip 145
 - SKF EMCOR rating 188
 - SKF Energy Monitoring Service 329–330
 - SKF Grease Test Kit 222
 - SKF greases 423–431
 - for SKF SYSTEM 24 lubricators 199
 - selection chart 430–431
 - SKF Lubrication Planner 180
 - SKF LubriLean 215
 - SKF Machine Condition Advisor 223
 - SKF Monoflex 215
 - SKF Multiflex 215
 - SKF Oil+Air 215
 - SKF ProFlex 215
 - SKF rating life 27–28
 - SKF Reliability Maintenance Institute 326–327
 - SKF SPEEDI-SLEEVE 225
 - installation 152–153
 - SKF Springcover 144–145
 - SKF Springlock groove 144–145
 - SKF SYSTEM 24 198–199
 - SKF tools and products
 - for alignment 419
 - for condition monitoring 432–434
 - for dismounting 435–436
 - for lubrication 420–422
 - for mounting 416–418
 - SKF traffic light concept 186–187
 - SKF V2F rating 188
 - SKF Vibracon SM elements 162–165
 - SKF WAVE seal lip 143
 - skidding *See* smearing
 - sliding *See* smearing
 - slotted elements *See* chocks
 - smearing
 - resulting in adhesive wear 301, 312
 - troubleshooting 244, 247
 - SNL housings *See* plummer block housings
 - soaps 183, 185
 - soft foot 162
 - solid additives
 - in centralized lubrication systems 213
 - in grease 184
 - in oil 203
 - solid contaminants 211–212
 - troubleshooting 245, 249
 - solid oil 182–183
 - solid seals
 - installation 133, 149
 - types and designs 144–145
 - solvents
 - for cleaning bearings 224
 - handling 225
 - types 254
 - SONL housings *See* plummer block housings
 - spacer lugs 144
 - spacer rings 91, 151
 - spacing washers 156
 - spalling 231
 - subsurface initiated 303–304, 309
 - surface initiated 301, 304, 310–311
 - troubleshooting 244, 249–250
 - speed factor 187
 - limits for grease lubrication 186, 194
 - SPEEDI-SLEEVE *See* SKF SPEEDI-SLEEVE
 - spherical roller bearings
 - axial drive-up values 403
 - clearance reduction values 403
 - designs 17
 - lock nut tightening angles 403
 - mounting 90
 - mounting (oil injection method) 62–66
 - mounting (SKF Drive-up Method) 57–61
 - radial internal clearance values 397–398
 - SKF Drive-up Method values 407–411
 - spheroidal graphite cast iron 126
 - spindle reconditioning services 331
 - spirit levels
 - for belt alignment 176
 - for shaft alignment 170
 - splines 150, 152
 - split plummer block housings *See* plummer block housings
 - split seals 133, 154–155
 - Springcover *See* SKF Springcover
 - stabilizing rings *See* locating rings
 - standstill
 - excessive voltage damage 307
 - moisture corrosion damage 317–318
 - vibration damage 319
 - start-up
 - of grease lubricated bearings 186–187, 190–191
 - of oil lubricated bearings 207
 - stationary inner ring 293
 - stationary load 32
 - stationary machine 167–168
 - storage
 - bearing damage 308
 - of bearings 41
 - of elastomer seals 42
 - of lubricants 42–43
 - straightedge method
 - for belt alignment 176–177
 - for offset drive alignment 175
 - for shaft alignment 170–171
 - subsurface initiated fatigue 298–299, 309
 - caused by defective seats 303
 - caused by incorrect fits 301
 - caused by static misalignment 304
 - suffix list
 - for bearing units 96
 - for bearings 24–25
 - for housings 127–128
 - for seals 145
 - super-precision bearings
 - greasing on initial installation 191
 - types and designs 12, 18
 - support surfaces
 - for bearing units 101
 - for housings 130
 - surface damage 233–235
 - surface initiated fatigue 298–299
 - caused by defective seats 303
 - caused by incorrect fits 301
 - caused by ineffective lubrication 310–311
 - caused by static misalignment 304
 - troubleshooting 249
 - surface roughness 36
 - mean values 387
 - surface wetting 202
 - sustainability 329–330
 - synthetic oil
 - in grease 183
 - in oil 203
 - SYSTEM 24 *See* SKF SYSTEM 24
- T**
- taconite seals 128–129
 - take-up housings 125–126
 - take-up units
 - dismounting 270–277
 - mounting 104–120
 - taper gauges 47–48

tapered roller bearings
 adjusting back-to-back arrangements 86–88
 adjusting face-to-face arrangements 84–85
 axial internal clearance values 396
 greasing on initial installation 191
 mounting 84–89
 trouble conditions 245
 types and designs 16–17

tapered shaft seats
 dismounting bearings 259–264
 measurement form 48
 mounting bearings 54–56

temperature
 ambient 161
 condition monitoring 221
 operating 186–187
 reference 203
 trouble conditions 233

temperature difference
 between inner and outer rings 221
 considerations for alignment 161
 considerations for fit selection 33
 trouble conditions 240

terminology 10–11
 test running 174

thermal cracking 298–299
 caused by incorrect fits 301

thermal expansion
 considerations for alignment 161, 169
 considerations for fit selection 33–34
 mounting CARB toroidal roller bearings 91

thermal inspection 221

thermometers 221

thickeners
 compatibility 201
 types 183

thrust bearings 18–19

tightening torque 166
 values for attachment bolts/nuts 105, 131
 values for bearing units 102–103
 values for cap bolts 131

tolerance classes See ISO, tolerance classes
 tolerance grades See ISO, tolerance grades
 tolerance tables
 for housings (inch) 372–381
 for housings (metric) 350–359
 for shafts (inch) 360–371
 for shafts (metric) 338–349
 for shafts (sleeve mounting) 384
 modified deviations for inch bearings 382–383

tools See SKF tools and products
 torque indicator 112–113
 torque keys See hexagonal keys
 Total Cost of Ownership 329
 total loss lubrication systems 214
 track runner bearings 19–20
 traffic light concept See SKF traffic light concept
 training 326–327
 transportation damage 308
 troubleshooting 228–251
 true brinelling 308

U

ultrasonic probes 221
 unbalance 243, 246
 unit conversion table 437
 units See bearing units
 universally matchable bearings
 axial internal clearance values 389
 axial preload values 389
 mounting 76

V

V2F rating See SKF V2F rating
 variable speed machines 223
 vertical shafts
 considerations for lubricant selection 182
 relubrication interval adjustment 195

Vibracon SM elements See SKF Vibracon SM elements
 vibration
 false brinelling damage 308, 319
 grease performance test 188
 relubrication interval adjustment 195
 troubleshooting 234
 vibration monitoring 222–224
 bearing defect frequencies 224
 taking measurements 223

viscosity
 calculation 204–206
 equivalents 414
 of base oil in grease 185
 of oil 203
 trouble conditions 246, 249
 viscosity grades See ISO viscosity grades
 viscosity index 203
 viscosity ratio 204
 VKA test 188
 voltage 307

V-ring seals
 installation in plumber block housings 135
 installation over a shaft 157
 removal 286

W

washboarding 322
 washdowns 29
 washers
 for bearing units 101
 for housings 131

water
 bearing damage 317–318
 contamination 181, 187, 212
 content in oil 210–211
 resistance of grease 183, 185, 188

WAVE seal lip See SKF WAVE seal lip
 wear 298–299
 abrasive 300–301, 313, 314–315
 adhesive 301, 312
 wear sleeves 152–153
 welding 172
 wheel hubs 87–88
 withdrawal sleeves
 dismounting bearings 264–267
 mounting bearings (oil injection method) 62–66
 mounting bearings (SKF Drive-up Method) 57–61

X

XNBR See acrylonitrile-butadiene rubbers

Y

Y-bearing units See bearing units
 Y-bearings
 assembly 121
 radial internal clearance values 401
 types and designs 21



PUB SR/P7 10001/1 EN · September 2011
ISBN 978-91-978966-4-1